

Wiring Diagram

LIFAN X50

1.5VVT/CVT/MT



Content

1. Content.		
2. Introduction	1	
3. Symbol	3	
4. Circuit Diagnosis	4	
Circuit Diagnosis Procedure.....	4	
Circuit Diagnosis Device.....	4	
Repair Tools.....	5	
Terminal Repair.....	6	
Poor Ground Connection Repair.....	7	
5. Wiring Diagram	9	
Charging System / Clock Power / Starting System.....	9	
Charging System / Clock Power / Starting System (PEPS).....	10	
Ignition System / Fuel System.....	11	
Electronic Control System.....	12	
Cooling System / AC compressor.....	13	
Air Conditioning / Rear Defroster / RearView Mirror Heating.....	14	
TCU System	15	
Cigarette Lighter / Horn / Seat Heating	16	
Headlamps / Daytime Running Lamp / Rear Fog Lamp.....	17	
Left and Right Turn Lamp / Hazard Warning Lamp	18	
Left and Right Turn Lamp / Hazard Warning Lamp(PEPS)	19	
Dome Lamp / Trunk Lamp / Sunroof / TPMS	20	
Width Lamps / Interior Lighting	21	
EPS System.....	22	
Instrument Cluster(I) / Reverse Radar.....	23	
Instrument Cluster (II) / Multi-Function Discreen.....	24	
CD System/MP5 System	25	
Power Window	26	
Power RearView Mirror.....	27	
Wiper / Washer System.....	28	
Central Locking / Theft Deterrent System.....	29	
Supplemental Restraint System.....	30	
PEPS System-1.....	31	
PEPS System-2.....	32	
ESP System.....	33	
ABS System / Brake Lamp / Parking Lamp / Reverse Lamp.....	34	
Diagnose Interface System.....	35	
6.Fuse and relay	36	
Engine Compartment Fuse and Relay Box.....	36	
IP Fuse and Relay Box.....	37	
Engine Compartment Fuse and Relay Box Power Distribution.....	39	
IP Fuse and Relay Box Power Distribution.....	40	
7.Ground Distribution	41	
		Ground Distribution G01-G02-G03-G04-G05..... 41
		Ground Distribution G11-G12-G13-G14..... 42
		Ground Distribution G15-G21-G22
		43
		Ground Distribution G23-G24-G25..... 44
		Ground Distribution G26-G27-G28-G31..... 45
		8.Harness Connector Location View 46
		Engine Harness Connector Location View..... 46
		Engine Compartment Harness Connector Location View..... 47
		IP Harness Connector Location View..... 48
		Body Harness Connector Location View..... 49
		Door Harness Connector Location View..... 50
		Airbag (8 Return Circuit)and Rear Bump Harness Connector Location View..... 51
		AC and Airbag(2 Return Circuit) Harness Connector Location View..... 52
		Roof Harness Connector Location View..... 53
		Tail Gate Harness Connector Location View..... 54
		9.Ground Point Location View 55
		Ground Point Location View-Engine-G02-G03-G04..... 55
		Ground Point Location View-CVT-G05..... 56
		Ground Point Location View-Engine Compartment-G11-G12-G13-G14-G15..... 57
		Ground Point Location View-IP-G21-G22-G23..... 58
		Ground Point Location View-Body-G24-G25-G28..... 59
		Ground Point Location View-SRS-G26..... 60
		Ground Point Location View-Tail Gate-G27-G31..... 61
		10.Harness Connector View 62
		Engine Harness Connector(E--) 62
		E01
		62
		E04-E05-E06-E07.....
		63
		E08-E09-E10-E11.....
		64
		E12-E13-E14-E15.....
		65
		E16-E17-E19-E21.....
		66
		E22-E23-E24-E25.....
		67
		E26-E27-E28-E29.....
		68
		E30-E31-E11.....
		69
		EI2-EU.....
		70
		Engine Compartment Harness Connector(U--) 71
		U01-U02-U03-U04.....
		71
		U05-U06-U07/U10.....
		72
		U08-U09-U13.....
		73
		U14-U15-U16-U17.....
		74
		U19-U20-U21-U23.....
		75
		U26-U27-U29.....
		76

Content

U30-U31.....	77	L01-L02-L03-L04	117
U32-UI1.....	78	L05-L06-LT.....	118
UI2(MT)-UI2(CVT).....	79	Door Harness Connector(D--)	119
UI3-UE	80	D01-D02-D03-D04.....	119
Instrument Harness Connector(I--)	81	D05-D06-D07-D08.....	120
I01-I02	81	D09-D10-D11-D12	121
I03-I04.....	82	D13-D14-D15-D16.....	122
I05-I06-I07.....	83	D17-D18-D19-DB1.....	123
I08-I09-I10.....	84	DB2-DI1.....	124
I11-I12-I13.....	85	DI2-DI3.....	125
I14-I15-I16.....	86	Roof Harness Connector(R--)	126
I17-I18-I19.....	87	R01-R02-R03.....	126
I20(MT)-I20(CVT)-I21.....	88	RI.....	127
I22-I23-I24.....	89	SRS Harness Connector(S--)	128
I25-I26.....	90	S01-S02.....	128
I27-I28-I29.....	91	S03-S04-S05-S06.....	129
I30-I32.....	92	S07-S08-S09-S10.....	130
I33-I34-I35-I36	93	S11-SI.....	131
I37-I38.....	94	Rear bump Harness Connector(M--)	132
I39-I40-I41.....	95	M01-M02-M03-M04.....	132
I42-I43-I44.....	96	M05-M06-M07-M08.....	133
I45-IR-IA.....	97	MB1-MB2.....	134
ID1-ID2.....	98	Air Conditioning Harness Connector(A--)	135
ID3-IU1.....	99	A01-A02.....	135
IU2(MT)-IU2(CVT).....	100	A03-A04-A05-A06.....	136
IU3-IS.....	101	A07-A08-AI	137
IB1.....	102	11.Abbreviations	138
IB2-IE1.....	103		
IE2	104		
Body Harness Connector(B--)	105		
B01-B02-B03-B04.....	105		
B05-B06-B07-B08.....	106		
B09-B10-B11-B12.....	107		
B13-B14-B15-B17	108		
B18-B19-B20-B21.....	109		
B22-B23-B24-B25.....	110		
B26-BD1-BD2.....	111		
BI1.....	112		
BI2-BM1.....	113		
BM2-BT.....	114		
Tail Gate Harness Connector(T--)	115		
T01-T02-TB.....	115		
TL.....	116		

Introduction

Central Lock and Theft Deterrent System

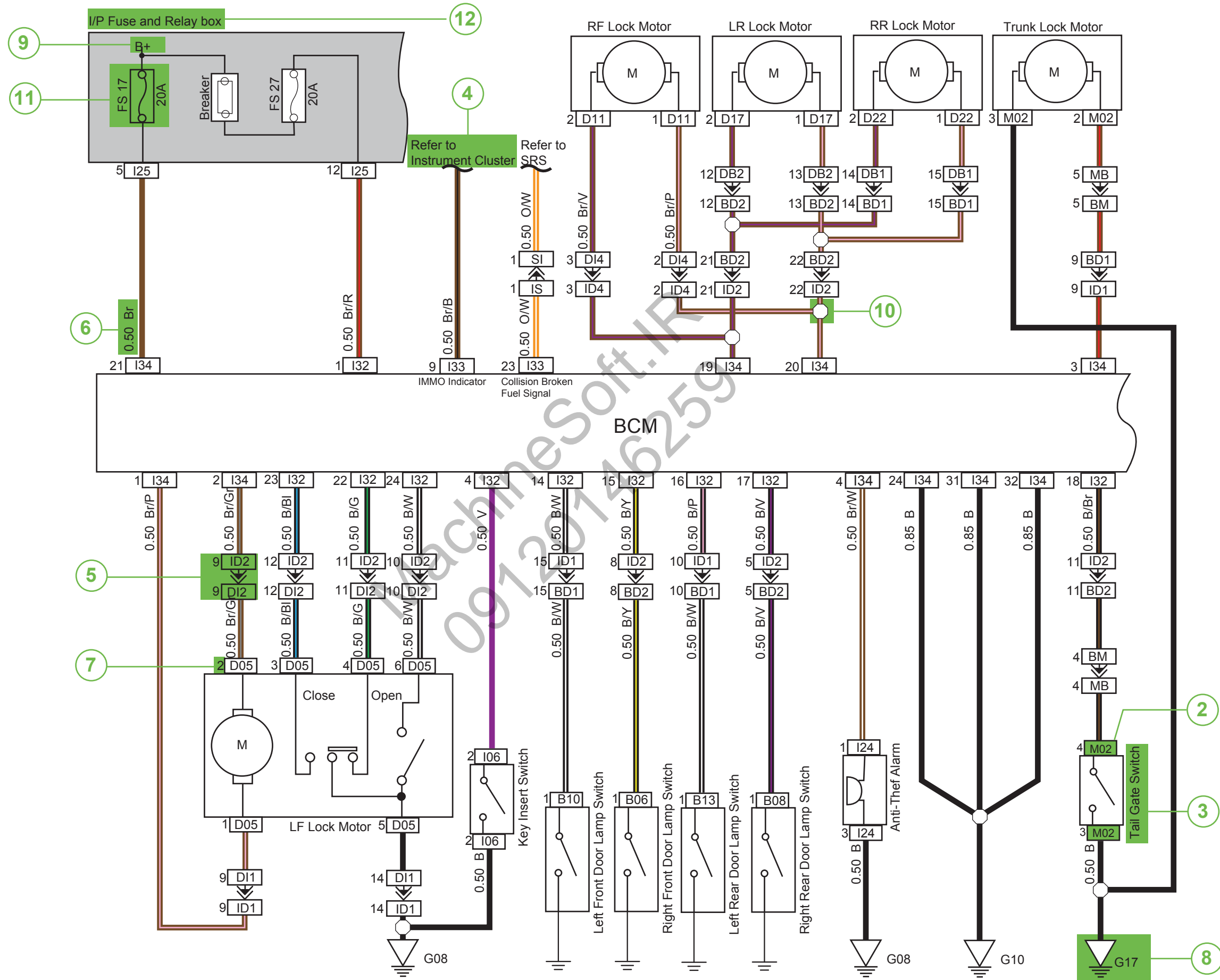

Introduction

1. System name.

2. Harness connector naming.

In this manual, the harness connector naming is based on harness. For example, I/P connector is named as I23. I is the harness code, 23 is the connector number.

The table below lists all harness:

Code	Harness
U	Engine compartment harness
U--	Engine compartment harness connector
E	Engine harness
E--	Engine harness connector
I	Instrument panel harness
I--	Instrument panel harness connector
B	Body harness
B--	Body harness connector
D	Door harness
D--	Door harness connector
A	A/C harness
A--	A/C harness connector
S	Airbag harness
S--	Airbag harness connector
R	Roof harness
R--	Roof harness connector
M	Rear Bumper harness
M--	Rear Bumper harness connector
T	Tail gate harness
T--	Tail gate harness connector



Note:

1. Door harness includes four door harness.
2. For harness connector details, please refer to connector location views.
3. Component name.
4. System information.
5. Harness to harness connector. The character in the box is the connector code.
6. Wire color and diameter. The following table shows the color code.

Color Code	Wire Color	Legend
B	Black	
Br	Brown	
Bl	Blue	
G	Green	
Gr	Grey	
O	Orange	
P	Pink	
R	Red	
V	Purple	
W	White	
Y	Yellow	

If a wire has two colors, the first character shows the background color and the second shows the stripe color, divided by "/". For example, YE/WH means yellow background color with white stripe.

7. Pin number. The connector pin numbers are mirrored to the ones that connect to them, as shown below:

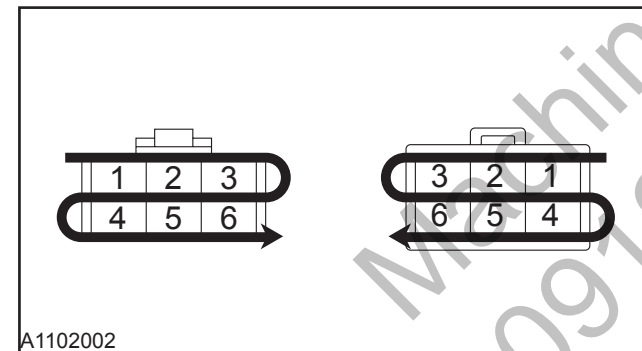

8. Ground number. The ground number starts with G. For ground details, please refer to ground location views.

9. Fuse supply. +B represents battery power supply. ACC represents power supply when ignition switch is at "ACC" position. IG2 represents power supply from terminal 4 when ignition switch is at "ON" position. IG1 represents power supply from terminal 2 when ignition switch is at "ON" position.

Note: The difference between IG1 and IG2 is that there is power supply output from IG1, but not from IG2 when the ignition switch is at "ST" position.

10. Splice

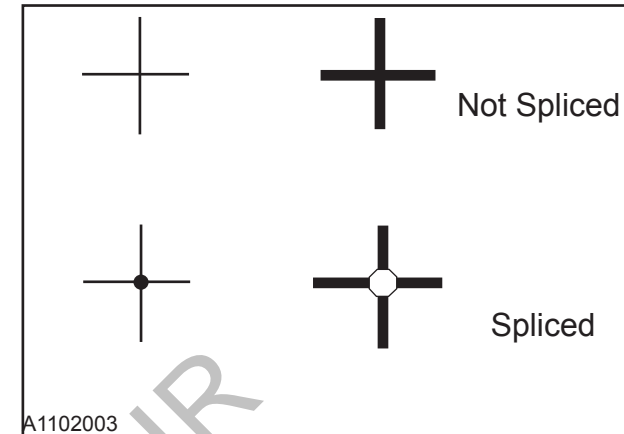

11. Fuse number consists of fuse code and a sequential number.

12. Grey shade means fuse and relay box.

Symbol

	Ground		Relay-Normally Closed		Battery
	Temperature Sensor		Relay-Normally Open		Capacitor
	Solenoid		Double Throw Relay		Cigarette Lighter
	Solenoid		Resistor		Antenna
	Light Load Fuse		Potentiometer		Switch - Normally Open
	Moderate Load Fuse		Rheostat		Switch - Normally Closed
	Heavy Load Fuse		Ignition Coil		Double Throw Switch
	Heater		Knock Sensor		Ignition Switch

	Ground		Relay-Normally Closed		UTP Unshielded Twisted Pair
	Temperature Sensor		Relay-Normally Open		Starter
	Solenoid		Horn		Fan Assembly
	Solenoid		Clock Spring		Oxygen Sensor
	Light Load Fuse		Airbag		Low Speed Fan Relay B
	Not Sliced		Sliced		

A1104002

Circuit Diagnosis

Circuit Diagnostic Procedure

Refer to the following procedure for the circuit diagnosis:

1. Confirm the Fault

To do the proper repair, confirm the fault described by the customer firstly. Inspect the relevant component carefully and make record. DO NOT disassemble the component before confirmation of the fault scope and causes.

2. Read the Wiring Diagram and Analyze the Causes.

Make a complete analysis on the faulty components from power supply to ground according to the sub-system wiring diagram and determine the repair solution. If can not determine the repair solution, please read the system description in the "Description and Operation" in the workshop manual to clear the working principle. And inspect other circuits that has common part with the faulty circuits that has common part with the faulty circuit, for example, the fuse, ground, switch, etc. Inspect the circuit not covered in step 1. If other components on the common circuit work properly, it means the fault exists in its own circuit. Otherwise, the fuse or ground might has faults.

3. Inspect the Circuits and Components.

Always use the wiring diagram together with workshop manual and refer to the diagnostic procedure for the relevant circuits or components in the workshop manual. For the circuit with a control module, fully use diagnostic tools to do the test. Effective diagnosis should be a logical and reasonable operation. Fully use the diagnostic procedures in the workshop manual and start the inspection from the most likely causes and the compents be easiest to inspect.

4. Repair

Repair the faulty circuit. Refer to the wiring diagram and workshop manual for fault treatment. For example, the treatment on bad connection to ground and the harness connector.

5. Confirm the Fault Removed.

After repair, confirm the fault removed and all functions work properly. For the fuse blown fault, check all the relevant circuits.

Circuit Diagnostic Device

1. Voltmeter and Test Light

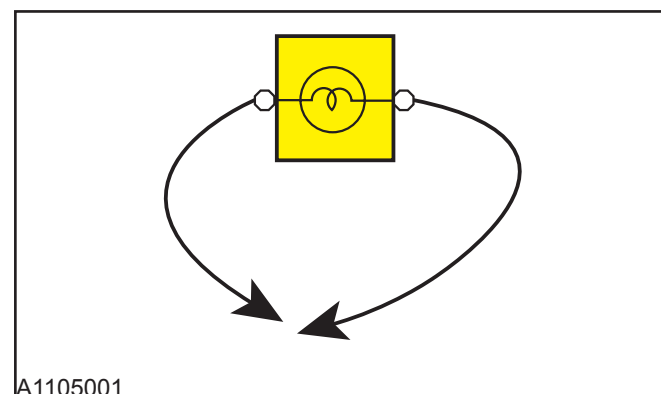

Use test light or voltmeter to check the circuit status.

Test light comprises a pair of wires and a 12V bulb. When inspecting, connect one wire to the ground and the other one to the measurement point. If the bulb is lit, it means the measurement point has power supply.

Warning: DO NOT use test light to test the control module voltage. To do so, it could damage the circuit inside the control module. Please use a voltmeter with 10M Ω or higher internal impedance (e.g. to test the ECM voltage).

Voltmeter has the same connection method as the test light, but voltmeter can display the voltage value of the circuit. Use a voltmeter with high impedance to test the voltage. If the circuit has poor connection, the voltmeter may show the normal value, but the voltage can not drive the load successfully.

2. Test Light with Self-supply and Ohmmeter

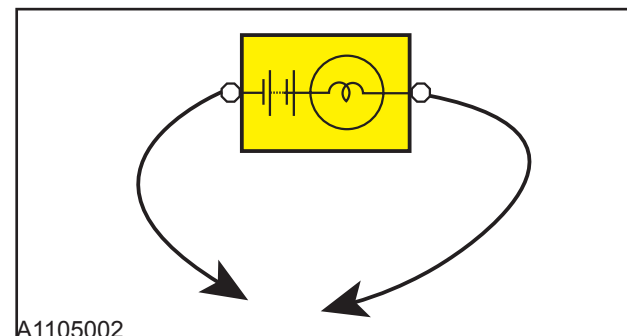

Use test light with own 12V power supply or ohmmeter to test the circuit continuity. Test light comprises a bulb, battery and a pair of wires. The bulb will be lit when the two wires contacted. Before test, disconnect the battery negative and pull out the fuse of the circuit to be tested. To test the circuit continuity, contact two wires to the two measurement points. If the bulb is lit, it means the circuit is continuous.

Warning: DO NOT use test light with self-supply to test the control module. To do so, it could damage the circuit inside the control module. Please use a ohmmeter with 10M Ω or higher internal impedance.

Ohmmeter has the same usage method as voltmeter, but ohmmeter can show the impedance value. The lower impedance, the better continuity.

3. Jumper with Fuse

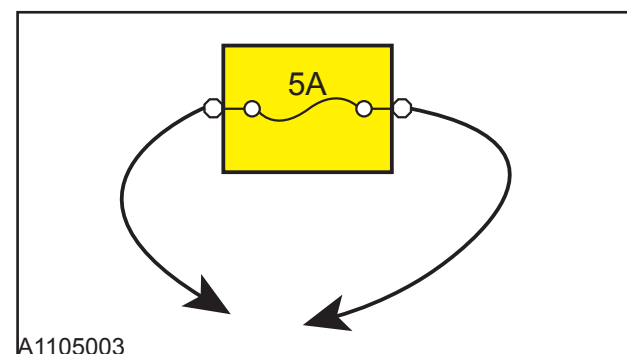

Use jumper to test a broken point for open loop circuit (circuit broken). The jumper should be in tandem with the circuit to be tested.

Warning: To protect the circuit, DO NOT use the fuse with higher rated capacity than the circuit to be tested. DO NOT use the jumper as the input or output signal when a control module like ECM, TCM is in the circuit. To do so, it could damage the circuit inside the control module.

Fault Test

1. Voltage Test

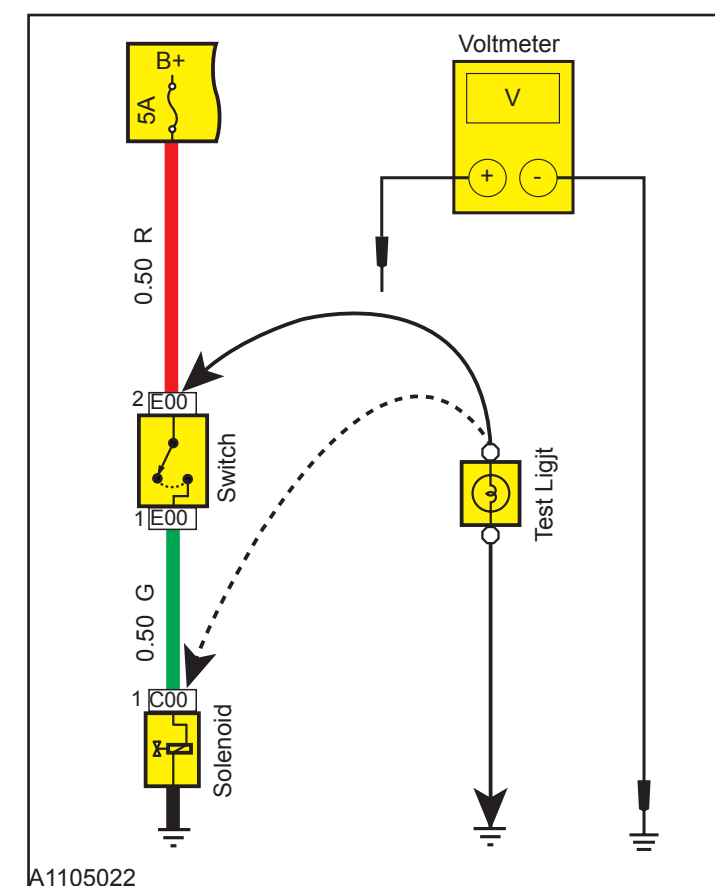

Voltage test process is to test the voltage at a certain point. When testing the connector terminals, insert the positive probe into the wire instead of breaking the harness.

1. When testing the voltage with test light or voltmeter, connect the negative wire of the test light or the negative probe of the voltmeter to the ground.

2. Connect the other wire of the test light or the positive probe of the voltmeter to the place to be tested.

Circuit Diagnosis

3. It means circuit fault if light is not lit. If using voltmeter and voltage display is lower than the rated value with more than 1V, it means the circuit fault.

2. Power Test

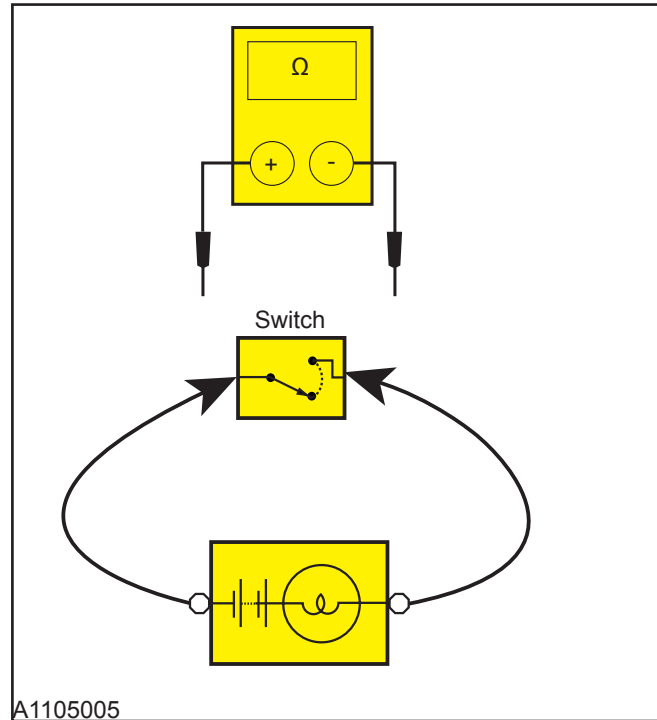

1. Disconnect the battery negative.
2. Connect one of the wire of the test light with self-supply or the probe of the ohmmeter to the component to be tested. If using ohmmeter, please contact the two probes each other and use reset button to adjust the ohmmeter to zero.
3. Connect the other wire of the test light or probe of the ohmmeter to the other side of the load to be tested.
4. If the bulb is lit, it means the circuit is continuous. If using ohmmeter, the impedance value should be very small or close to 0 Ω.

3. Short Circuit Test

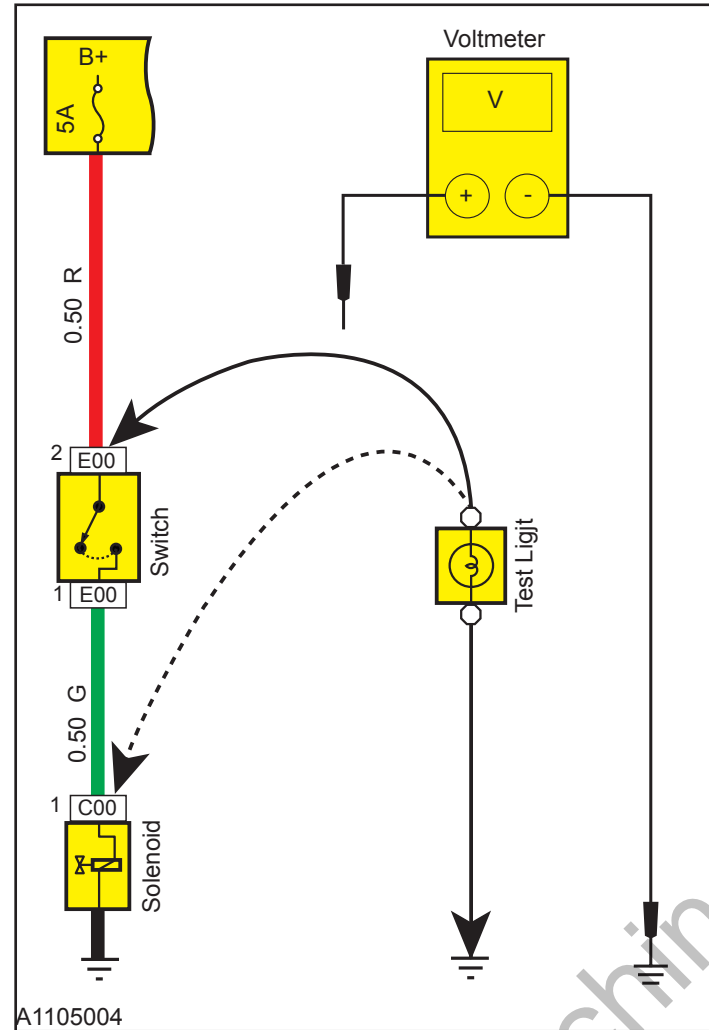

1. Disconnect battery negative.
2. Connect one of the wire of the test light with self-supply or the probe of the ohmmeter to the outlet terminal of the fuse.
3. Connect the other wire of the test light or probe of the ohmmeter to the ground.
4. Disconnect all the loads to the fuse.
5. **⚠ Note: If not disconnect all the loads to the fuse, when testing the low impedance circuit like lights, the ohmmeter will always display the low impedance value. This will cause wrong judgement.**
5. Do the careful test from the place closest to the fuse.
6. If the bulb is lit or ohmmeter has value display less than 5 Ω, it means the short circuit to the ground.

4. Voltage Drop Test

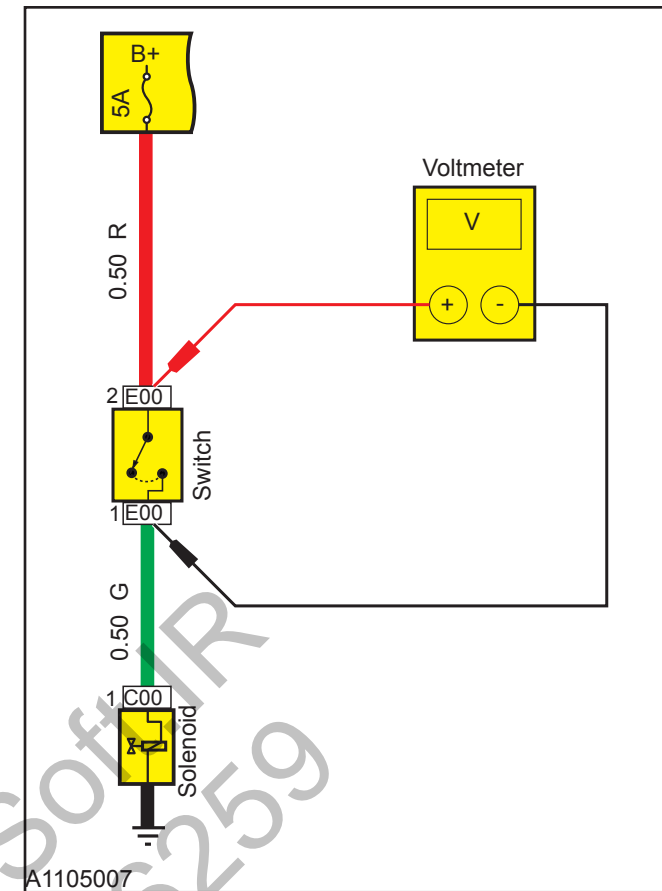

This is to test the voltage drop along the wire, connector or switch.

1. Connect the positive probe of the voltmeter to the end of the circuit close to the battery (connector or switch side).
2. Connect the negative probe to the other end of the circuit (the other side of the connector or switch).
3. Disconnect switch or connect it.
4. The voltmeter will display the voltage drop between the two test points.
5. If the drop is more than 0.1 V (less than 50 mV for 5 V voltage circuit), it means the circuit fault. Check loose, oxidation or corrosion circuit.

Repair Tools

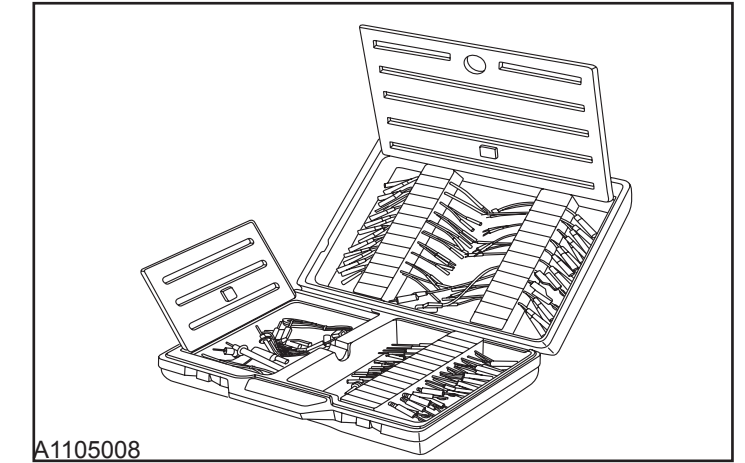

1. 5KΩ Rheostat

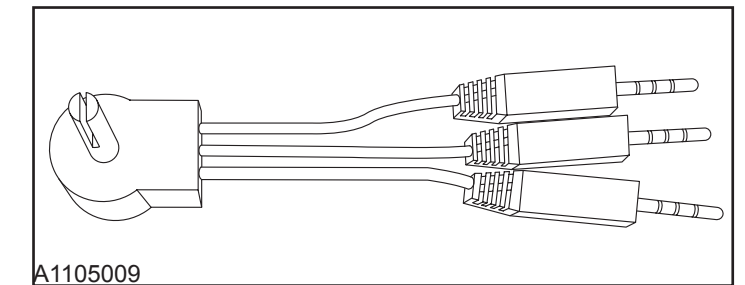

It can simulate ohm-type sensor signals, like coolant temperature sensor, air intake temperature sensor, etc. And help to make quick adjustment on the performance of the component.

2. LED Test Light

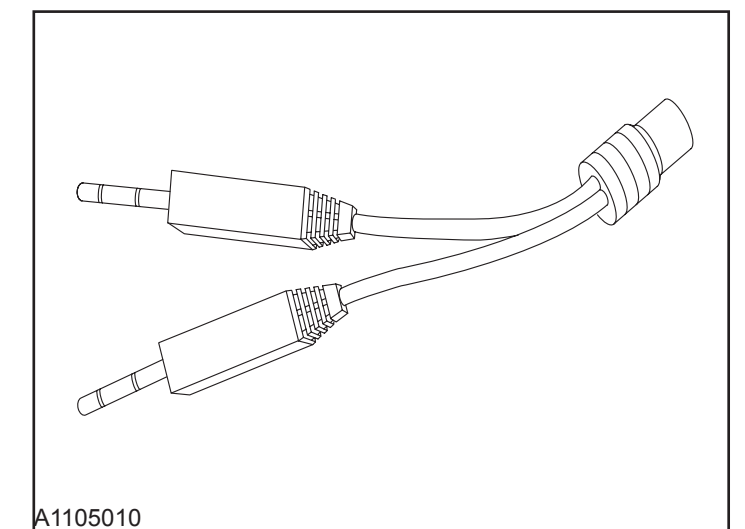

Circuit Diagnosis

Bi-direction two-color LED light can change its color when exchanging the positive and negative. This feature can be used to test the PWM control signals of Hall sensor.

3. Airbag Test Tool

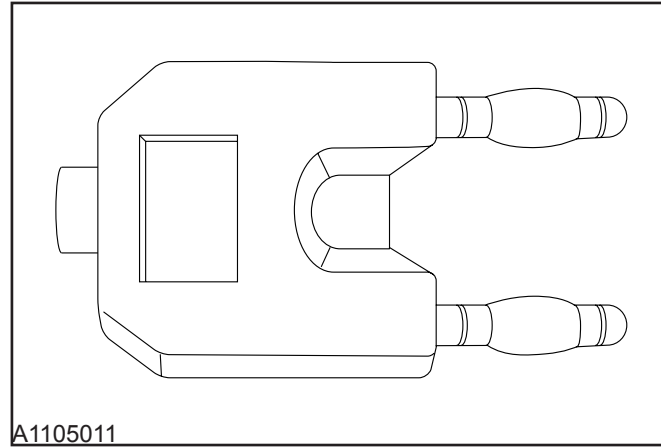

A1105011

Before installing a new airbag, plug this tool to the airbag system, and use diagnostic tools to test the airbag system to confirm it works properly. After that, remove the airbag test tool and install the new airbag. This process can guarantee a safe airbag operation.

4. Probe

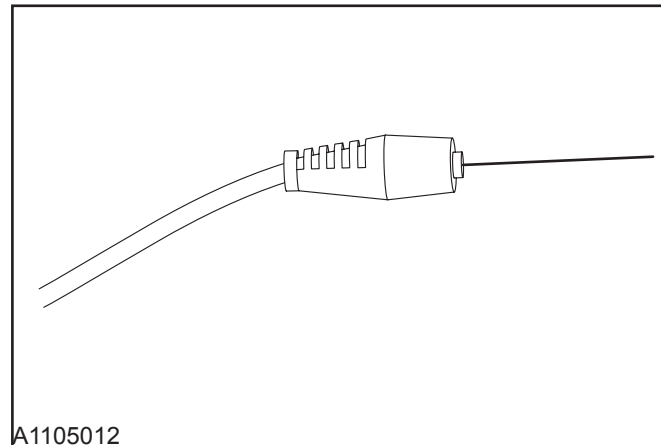

A1105012

When testing a system component, insert this tool into the connector from the back and do not need to break the harness.

5. Terminal Repair Tool

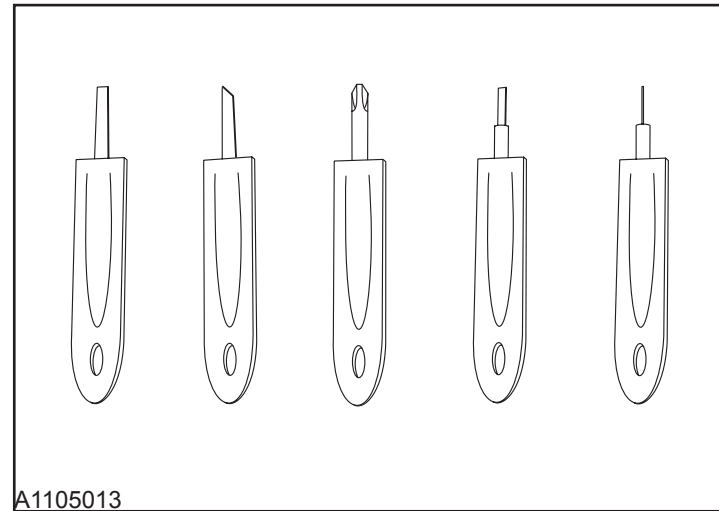

A1105013

When repairing the terminals, use this tool to separate them from the connector.

Terminal Repair

1. Remove the terminal pin.

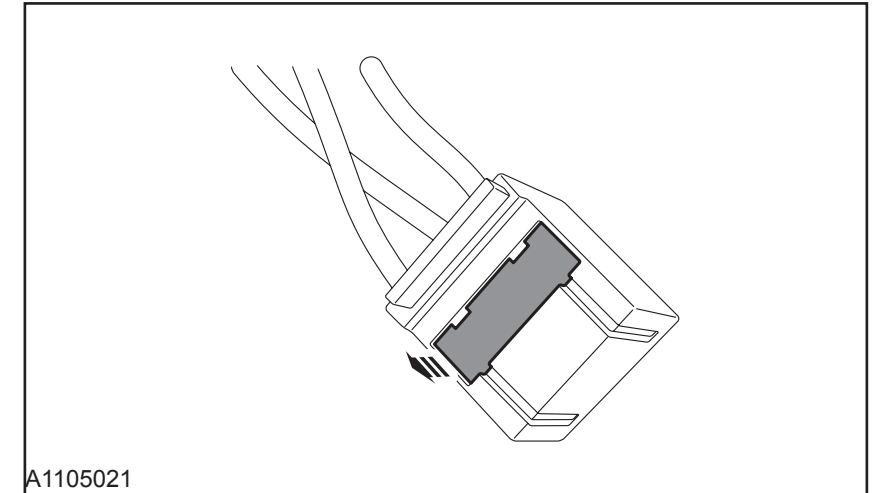

A1105021

2. Fix the clip with terminal repair tool.

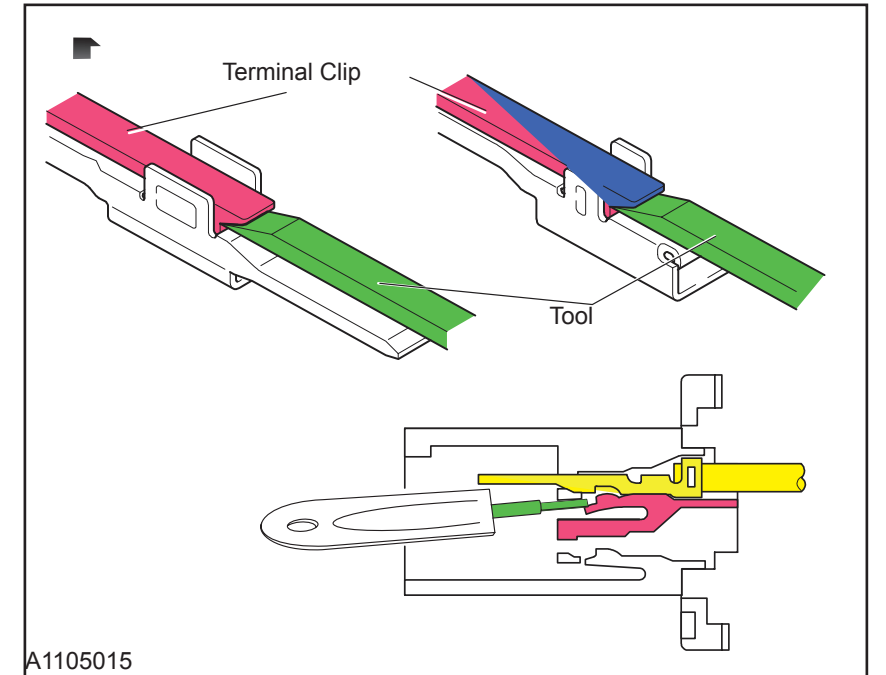

A1105015

3. Pull out the terminal from the rear of connector.

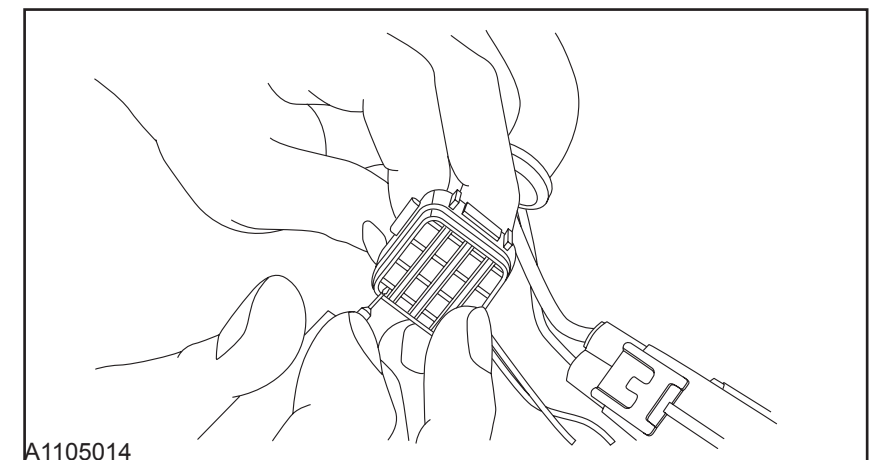

A1105014

Circuit Diagnosis

4. Clean and repair the terminals.

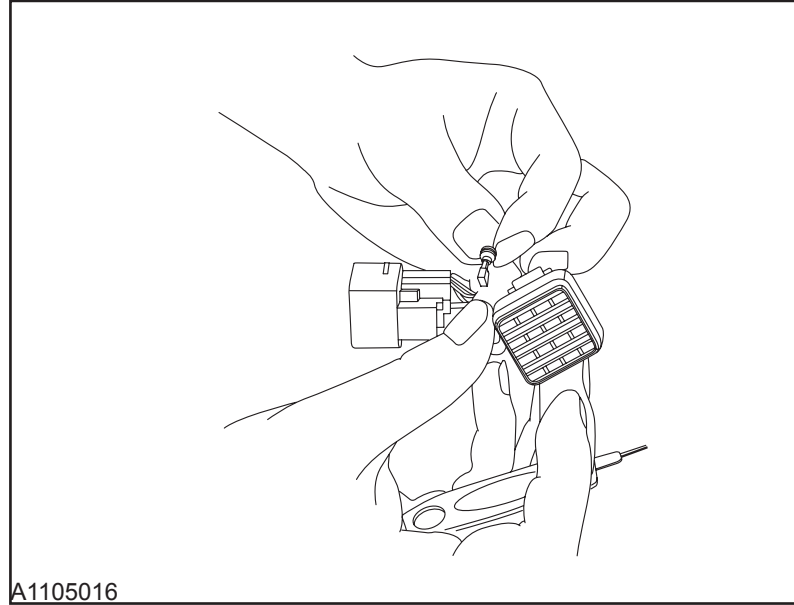

Poor Ground Connection Repair

1. Remove the ground bolt.

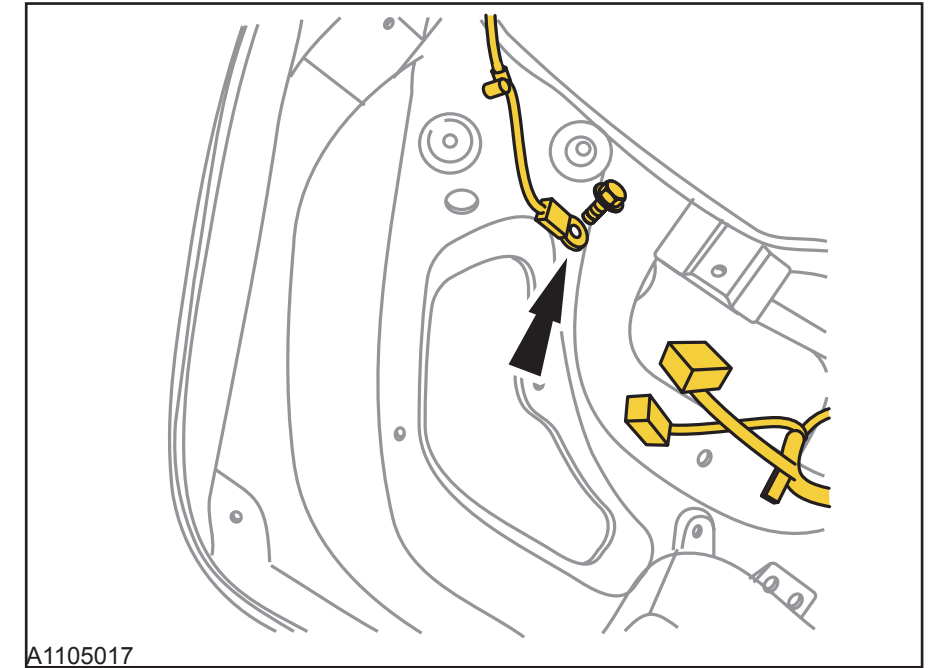

2. Clean the two surfaces (both bolt side and car contact side) of the copper ring with grit cloth until the oxide completely cleared.

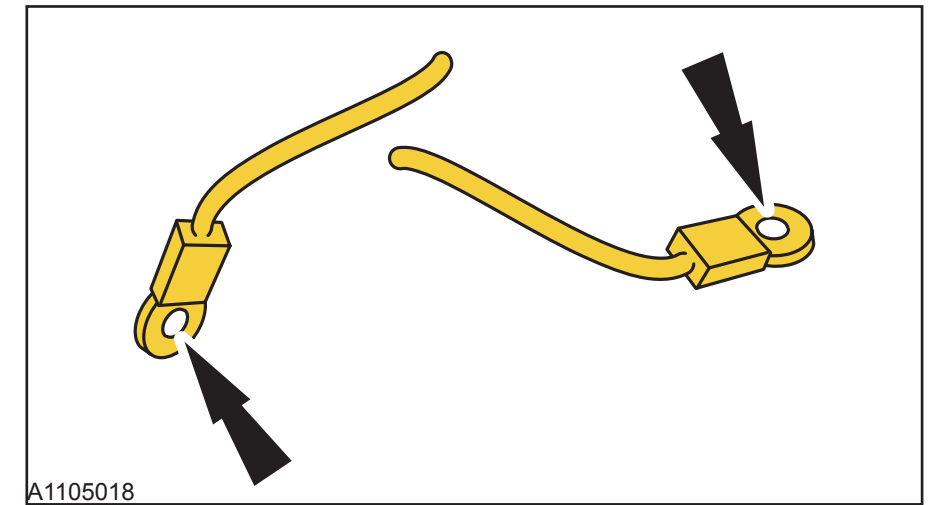

3. Clean the ground surface on the car with grit cloth until it completely clean.

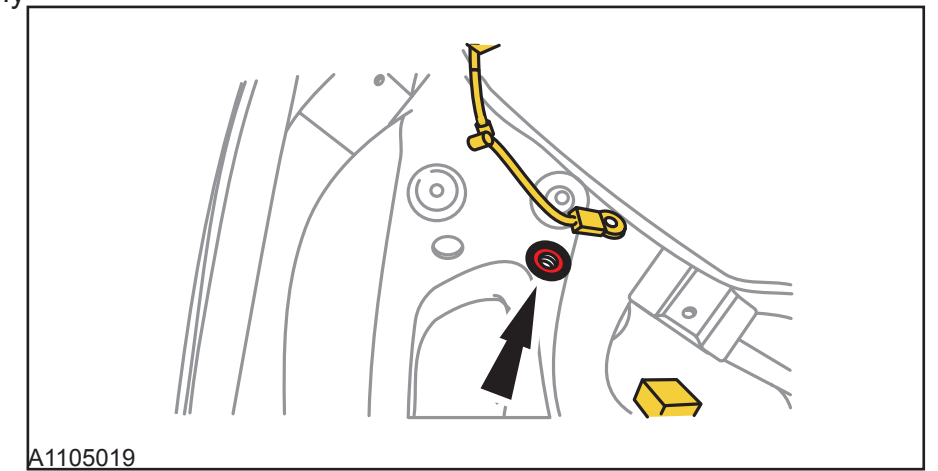

Circuit Diagnosis

4. Install the harness and the bolt. Tighten to specified torque.

Torque: M6 Bolts 8 Nm/M8 Bolts 20 Nm

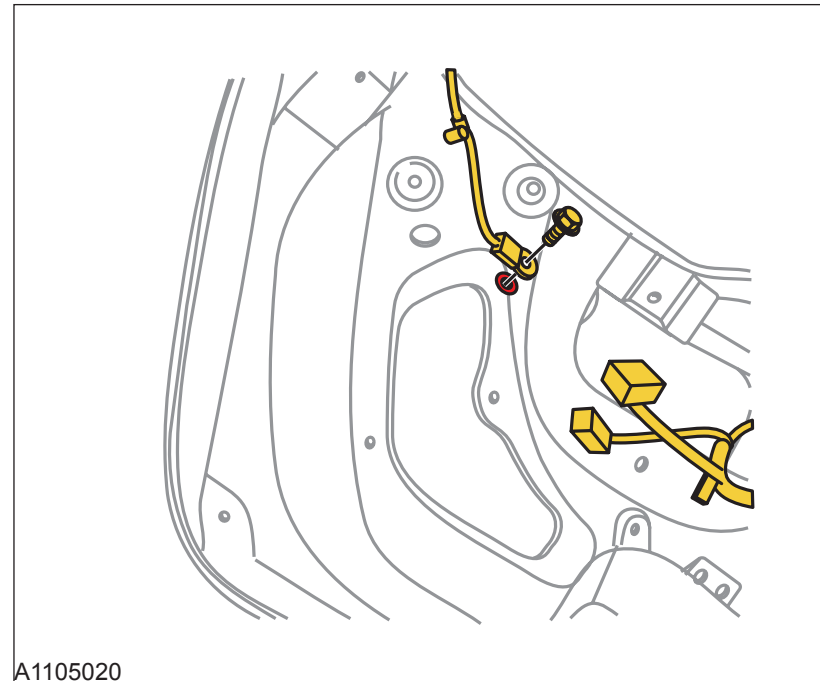

A1105020

MachineSoft.IR
09120146259

Charging System / Clock Power / Starting System

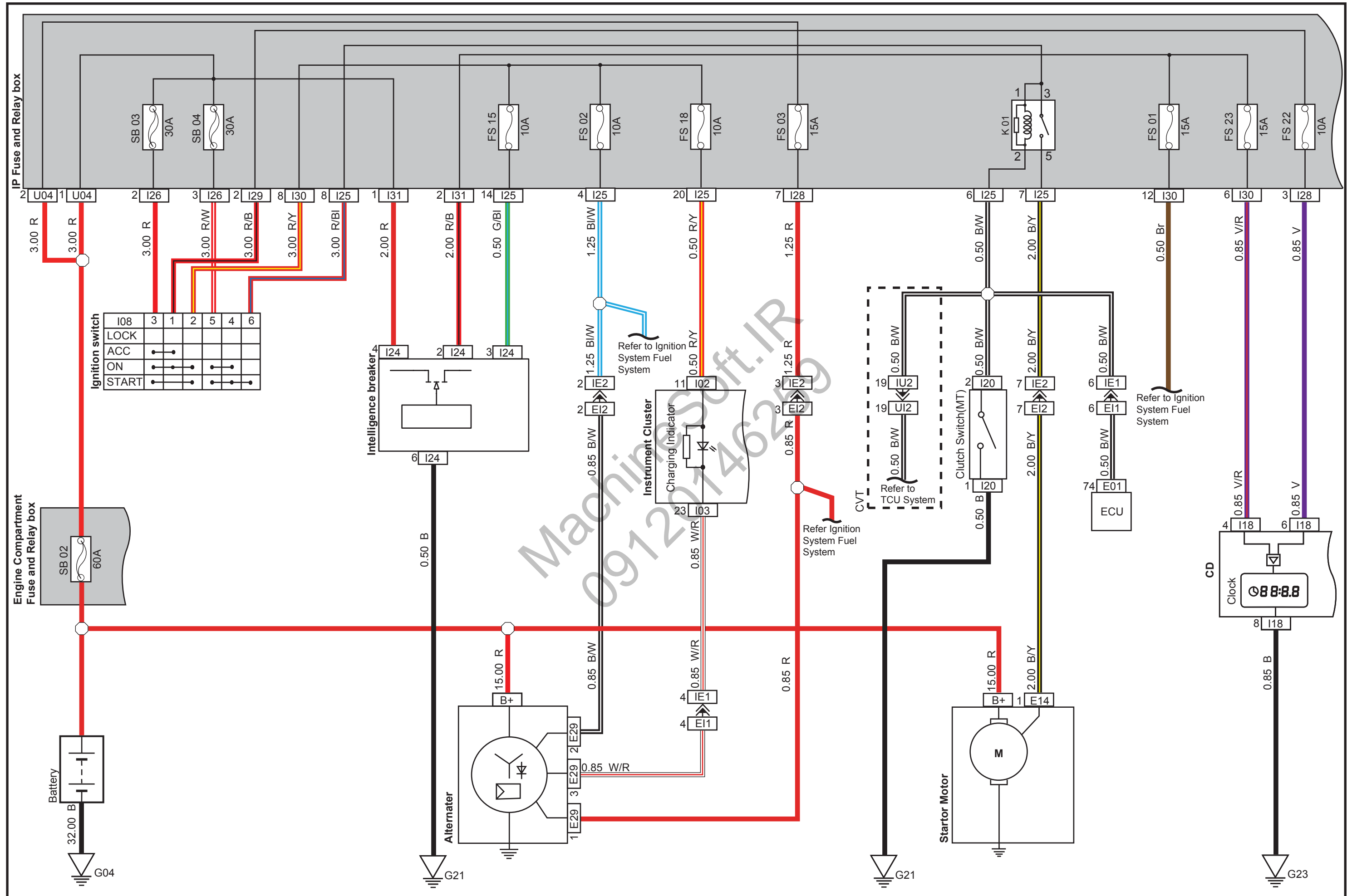

Ignition System / Fuel System

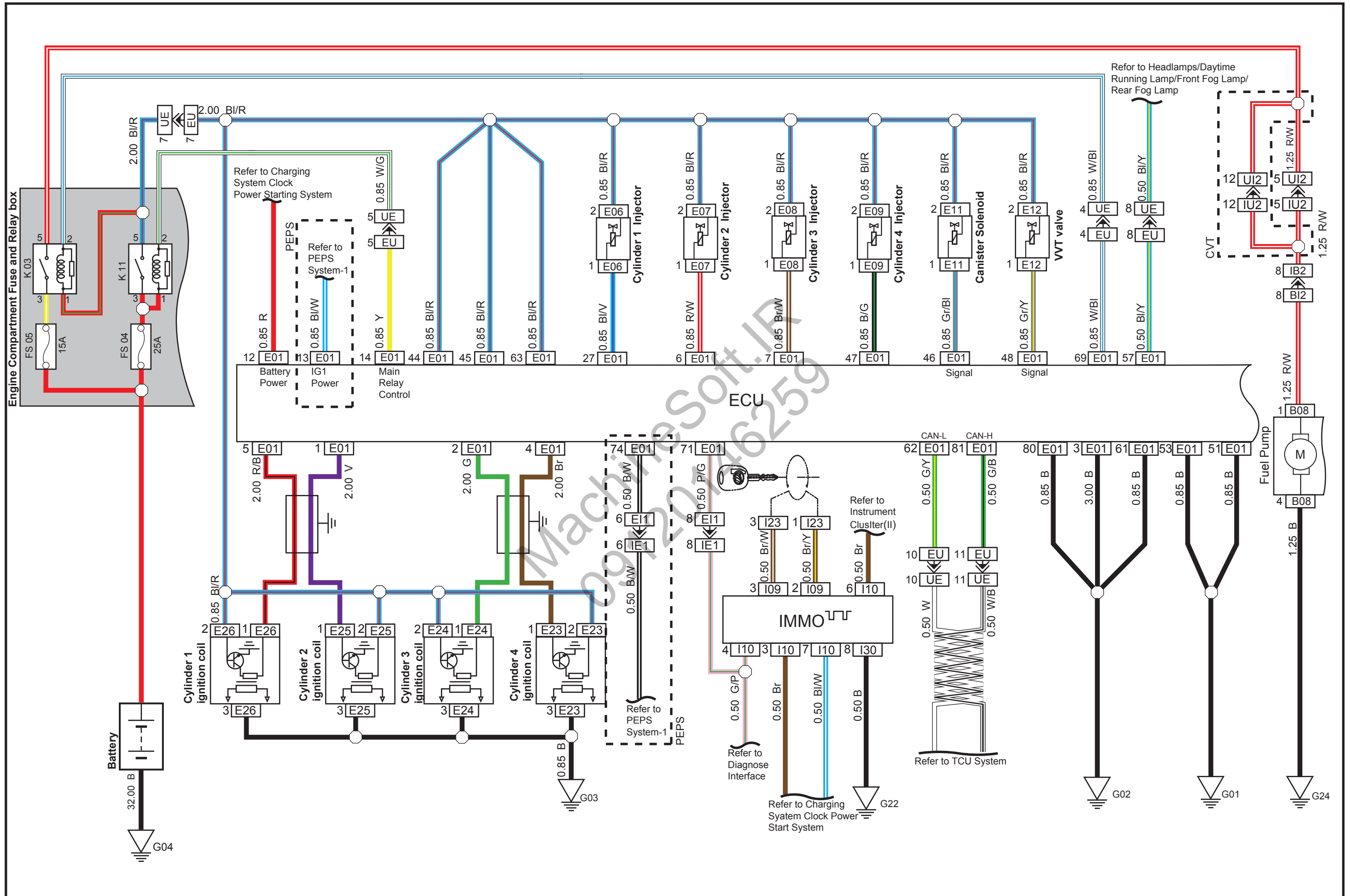

Electronic Control System

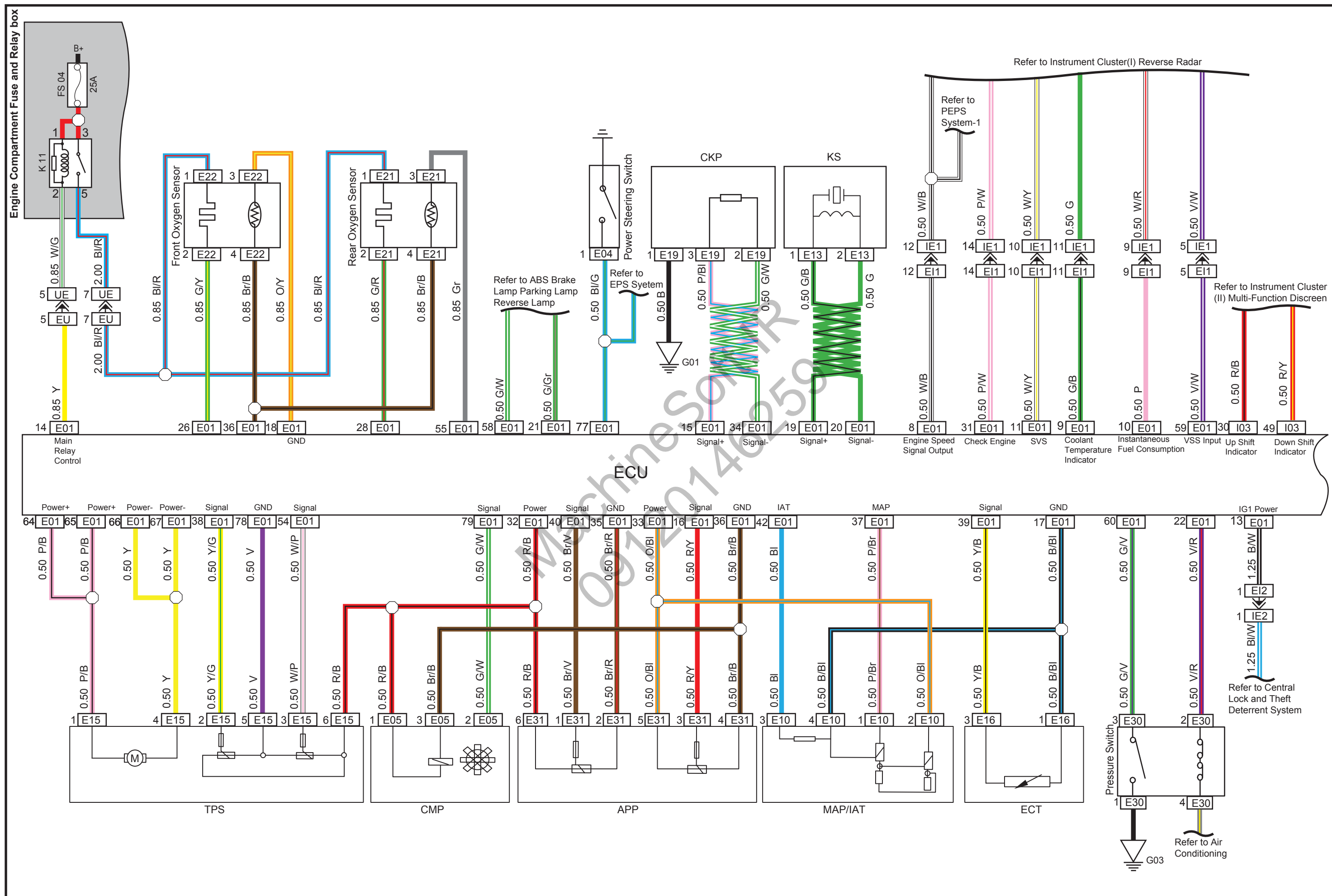

Cooling System / AC compressor

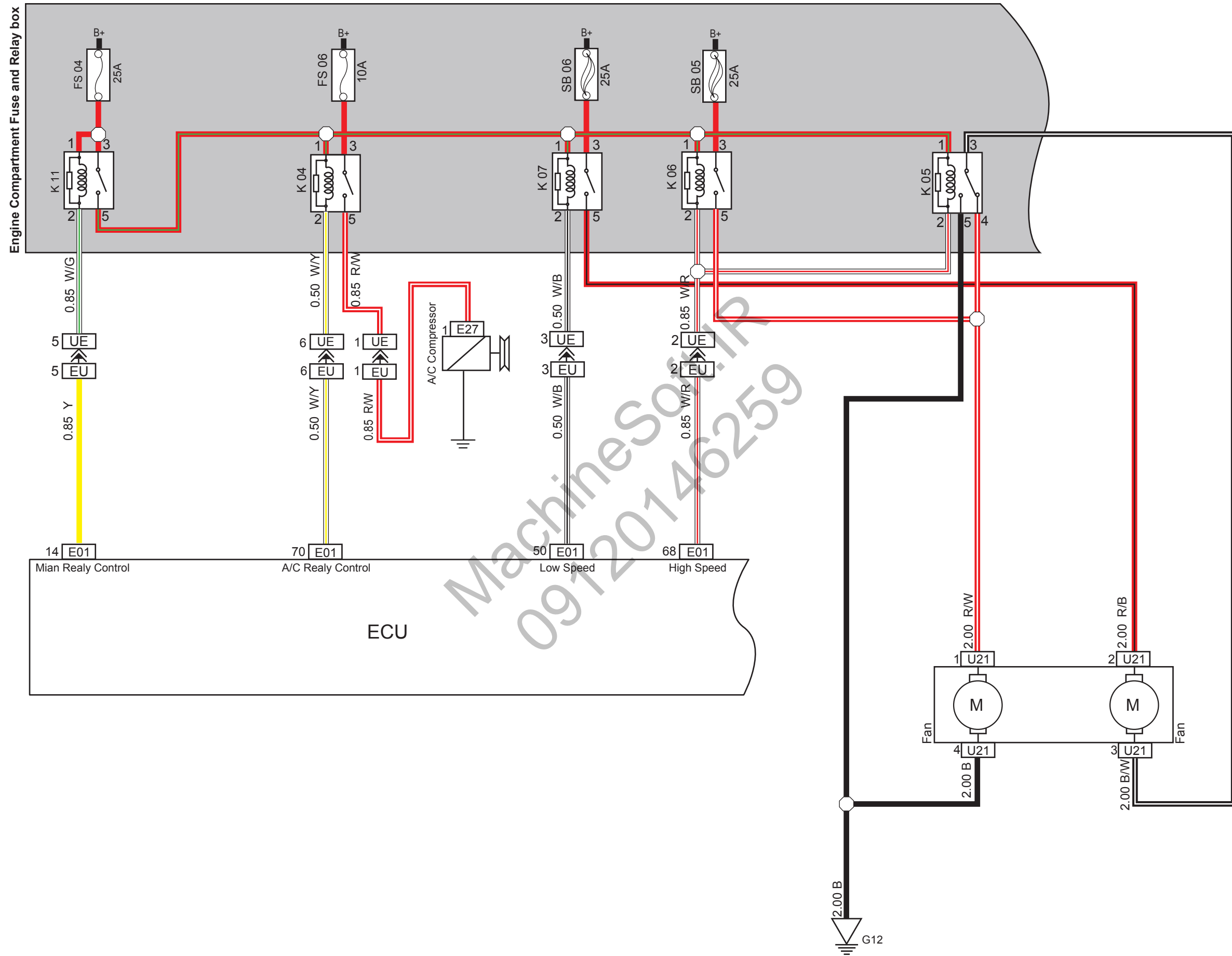

Air Conditioning / Rear Defroster / RearView Mirror Heating

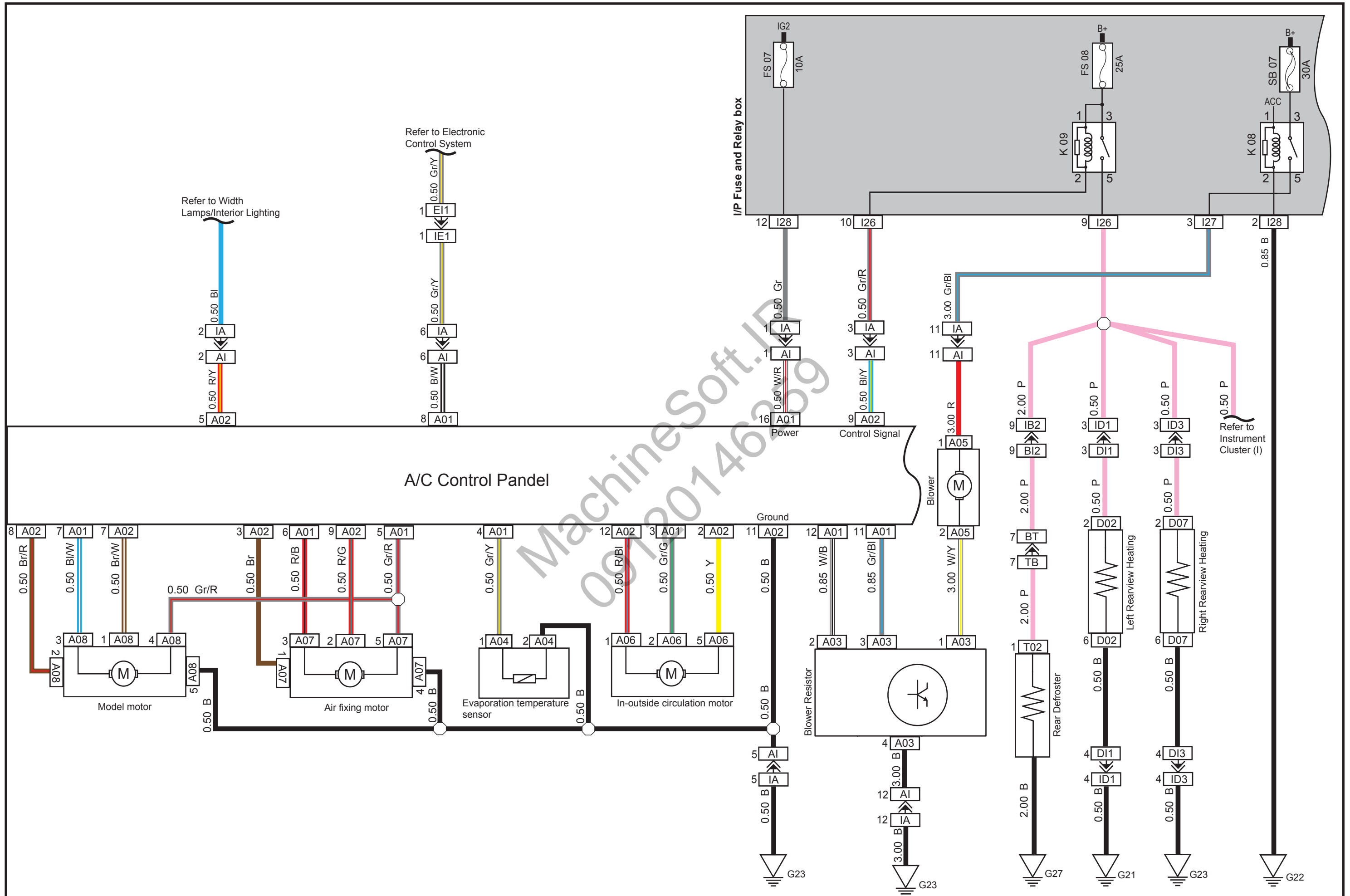

Cigarette Lighter / Horn / Seat Heating

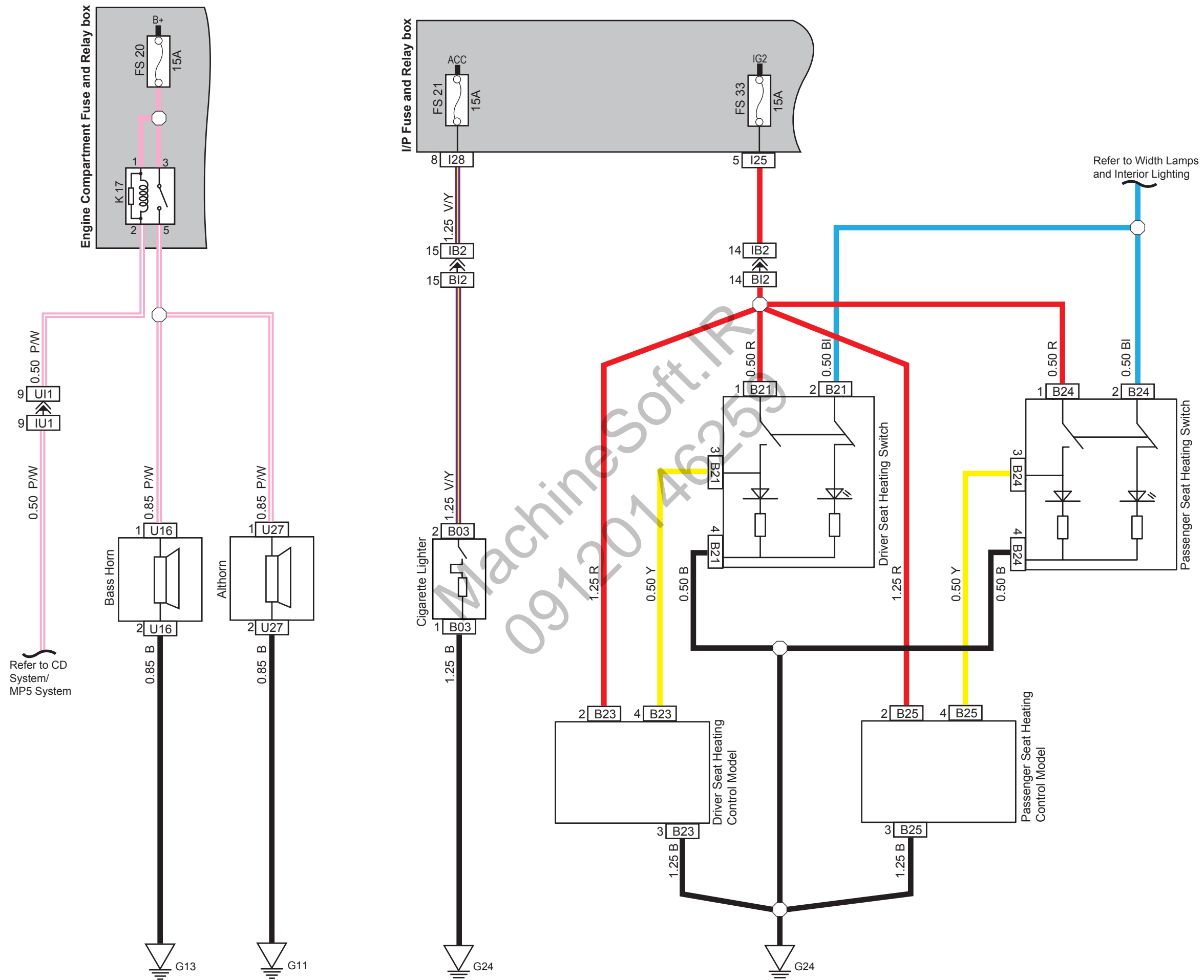

Headlamps / Daytime Running Lamp / Rear Fog Lamp

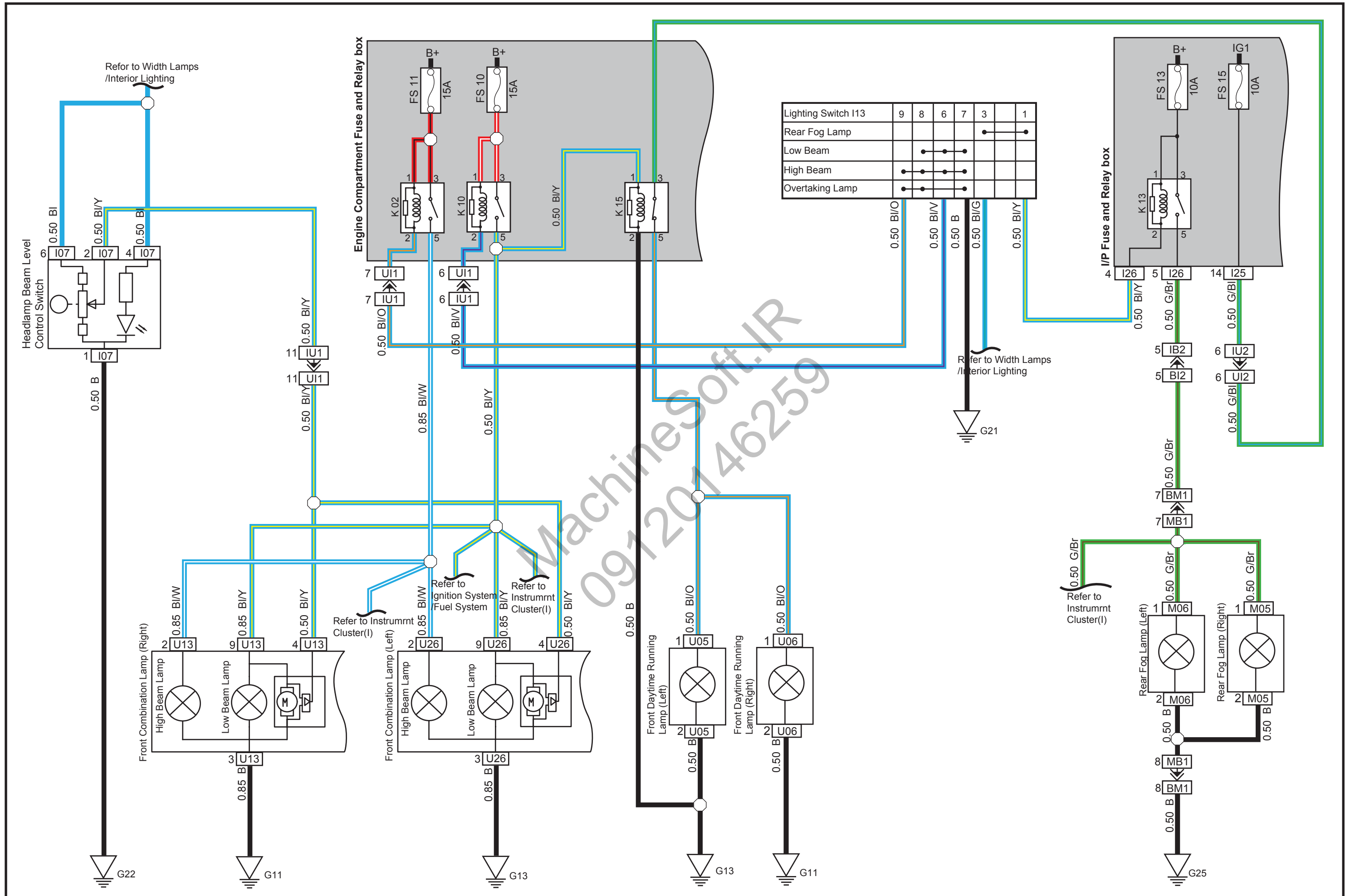

Left and Right Turn Lamp / Hazard Warning Lamp

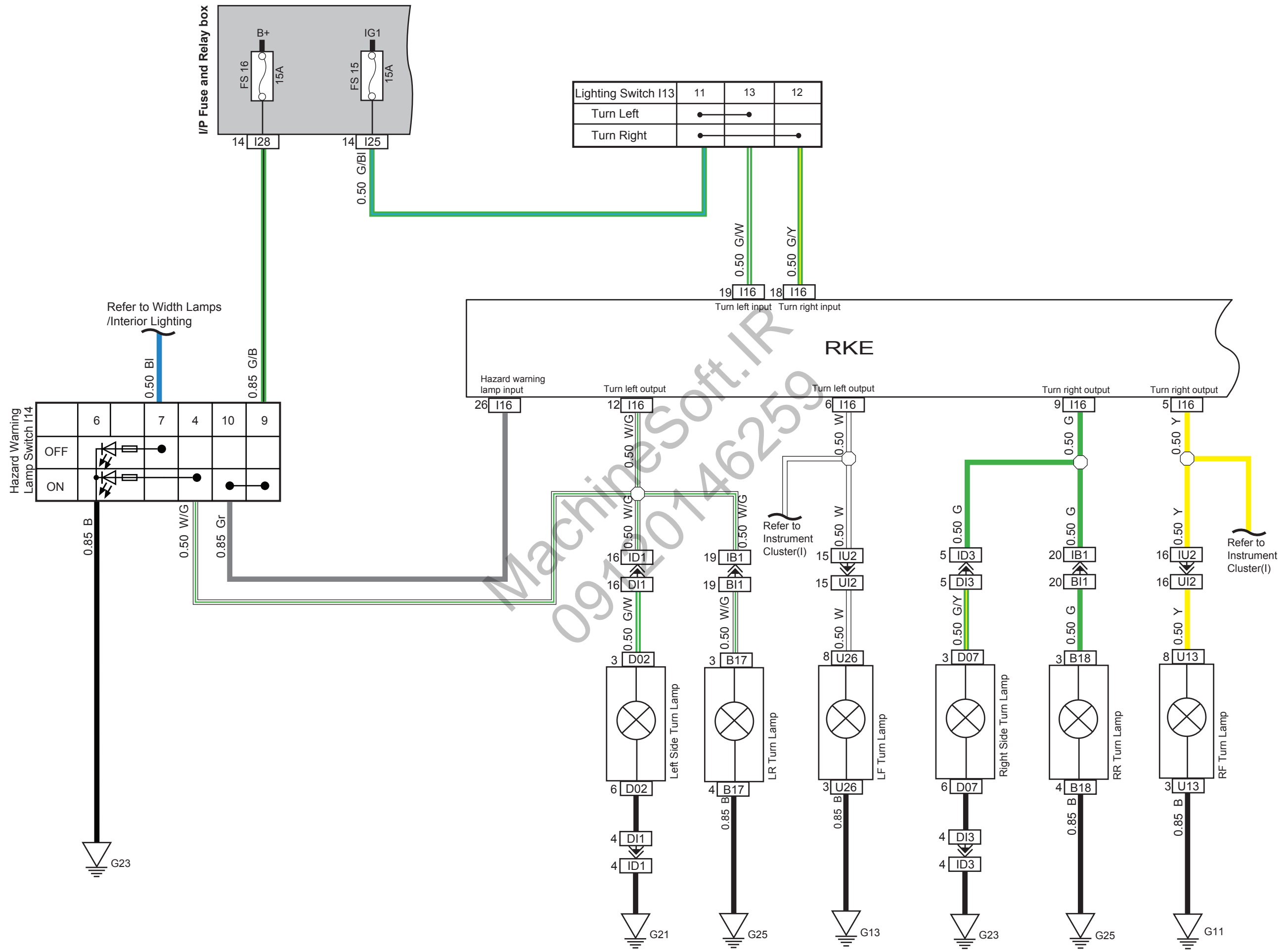

Left and Right Turn Lamp / Hazard Warning Lamp(PEPS)

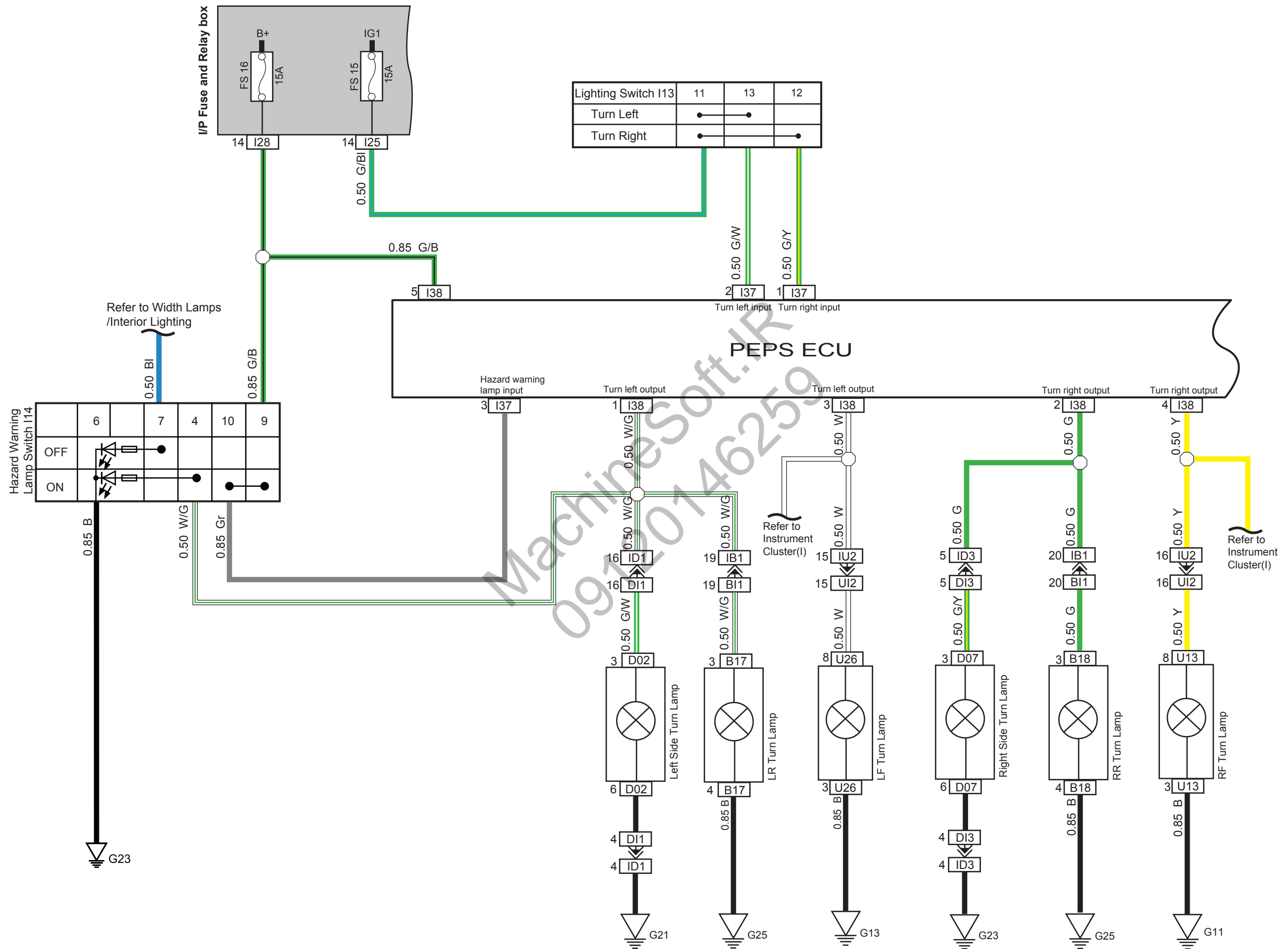

Dome Lamp / Trunk Lamp / Sunroof/ TPMS

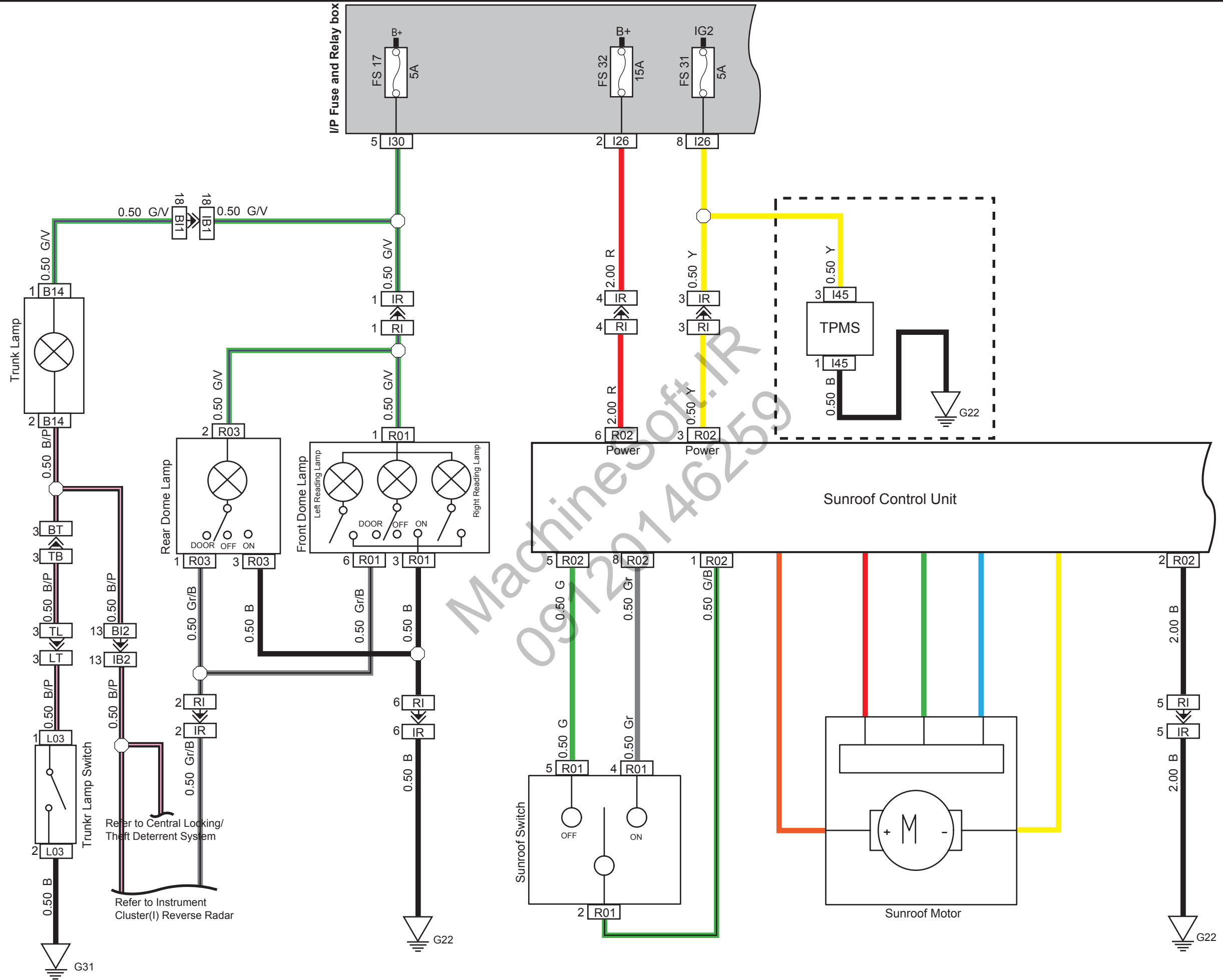

Width Lamps / Interior Lighting

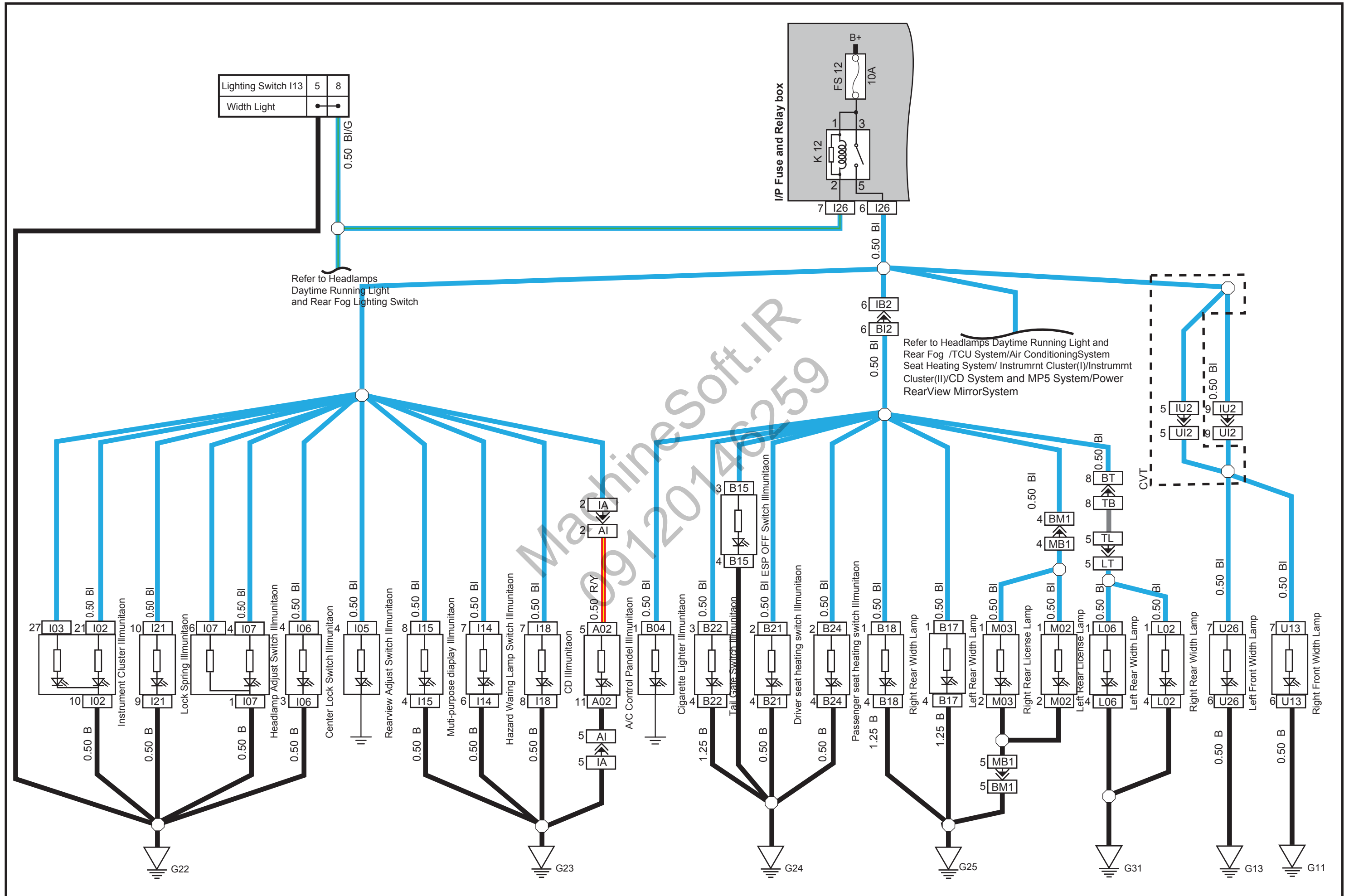

EPS System

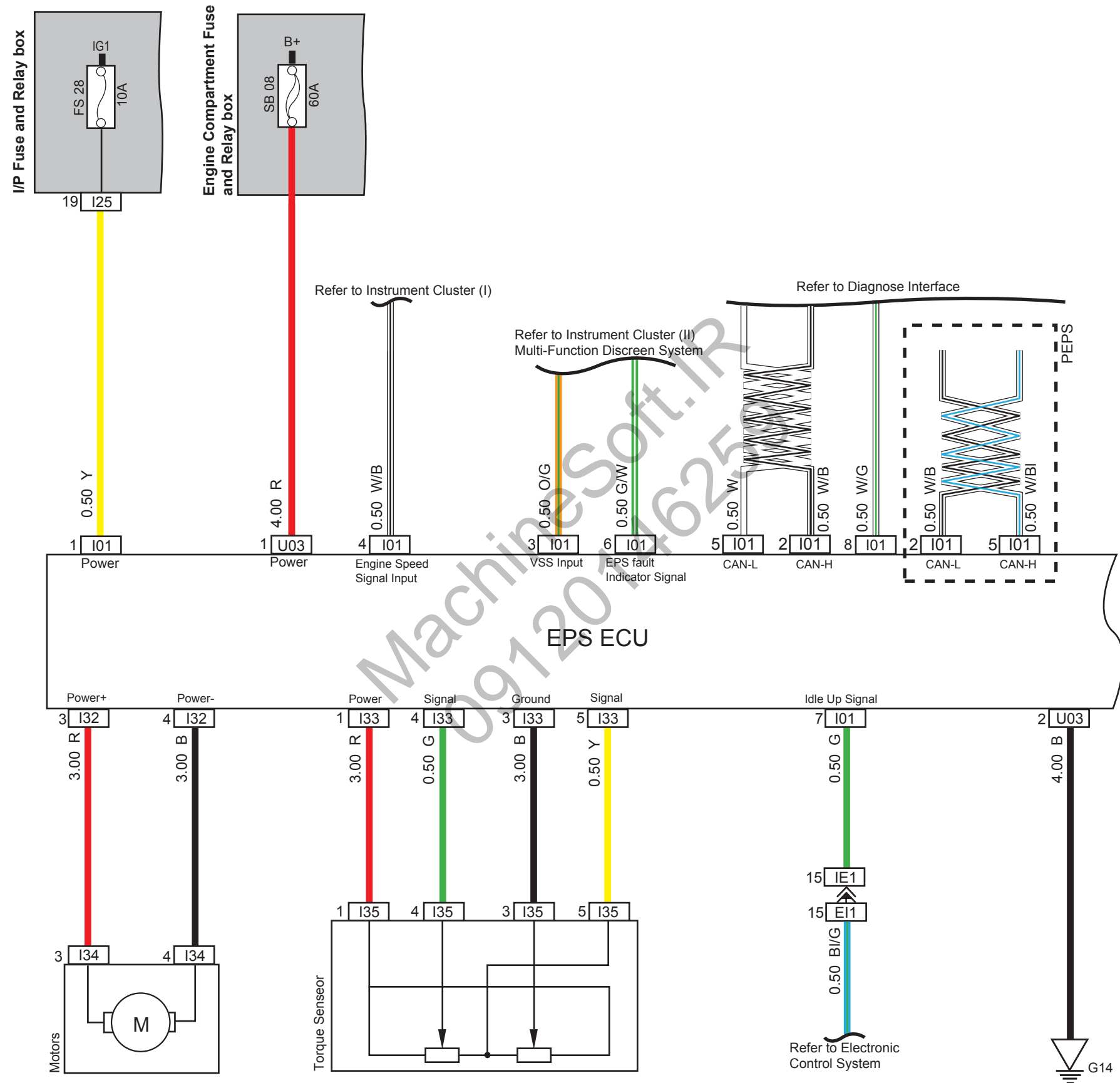

Instrument Cluster(II) Multi-Function Discreen

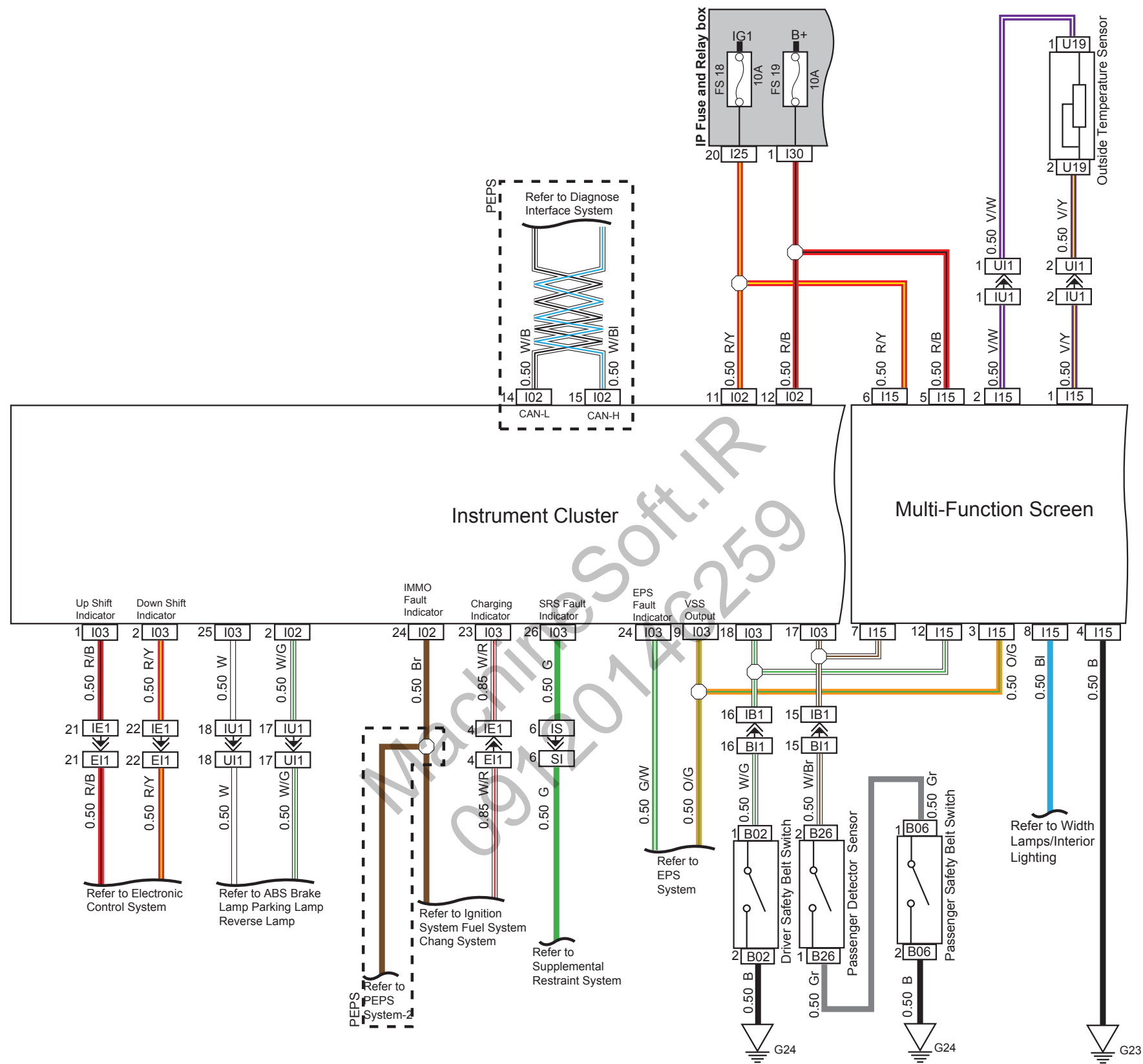

CD System / MP5 System

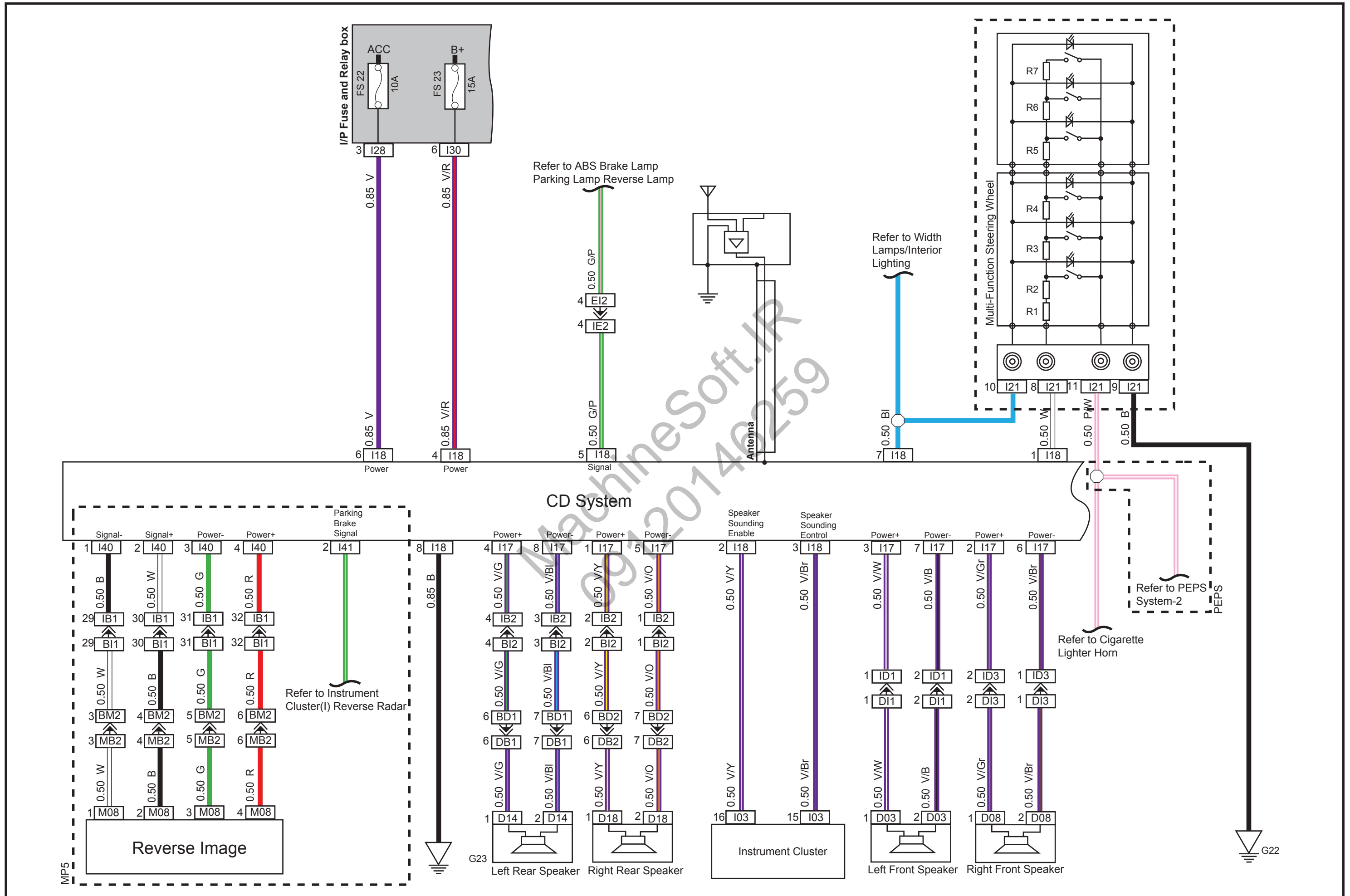

Power Window

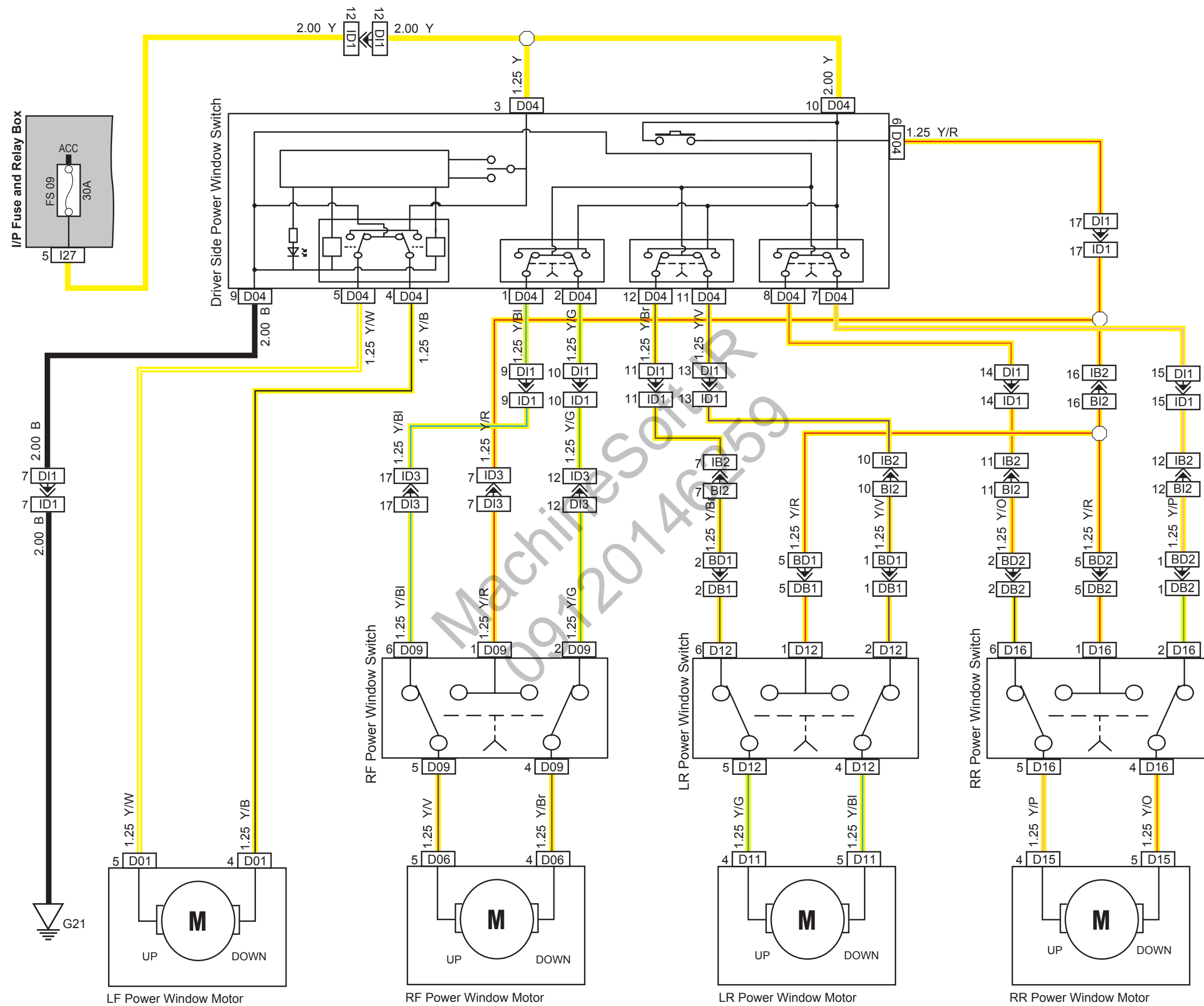

Power RearView Mirror

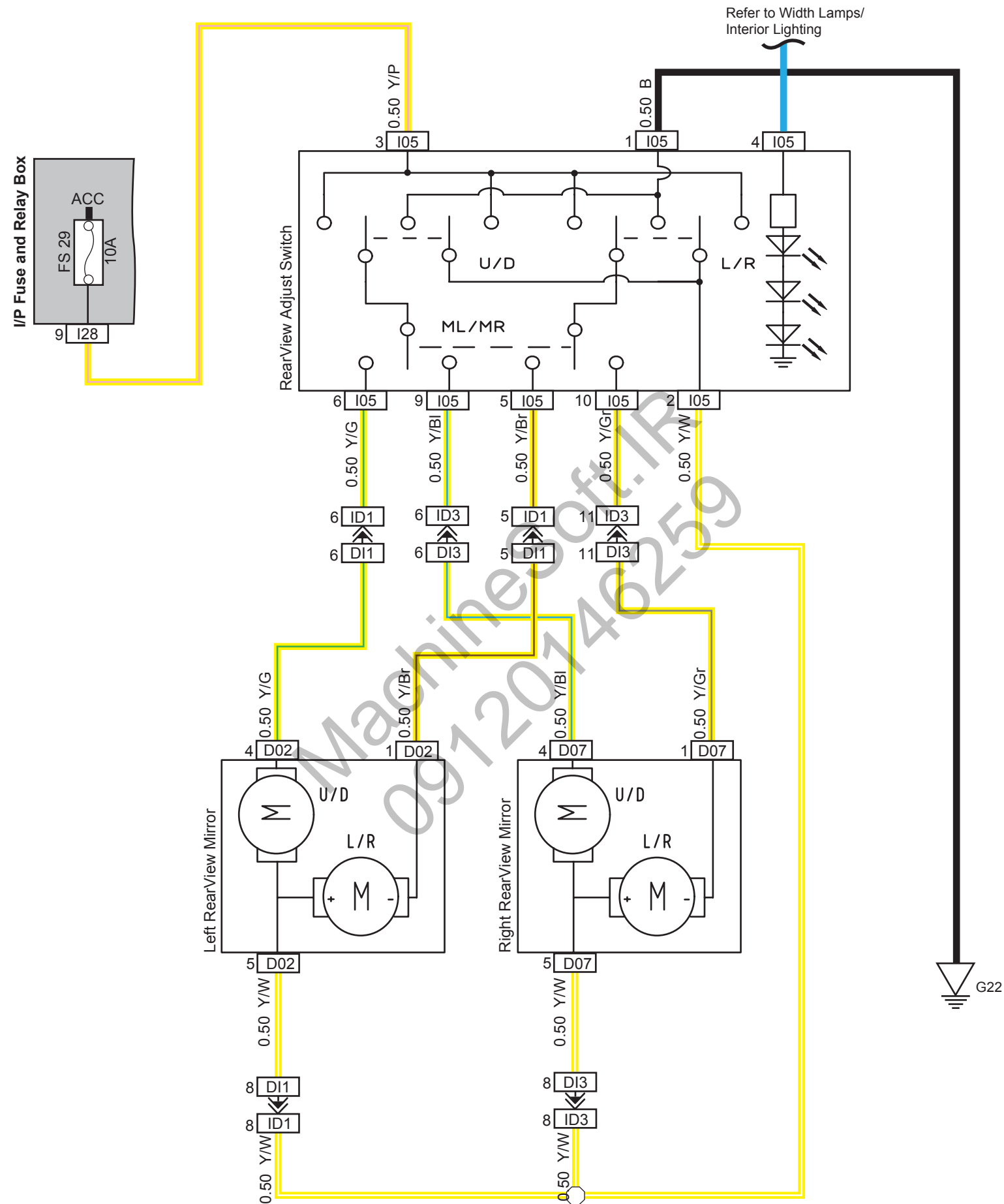

Wiper / Washer System

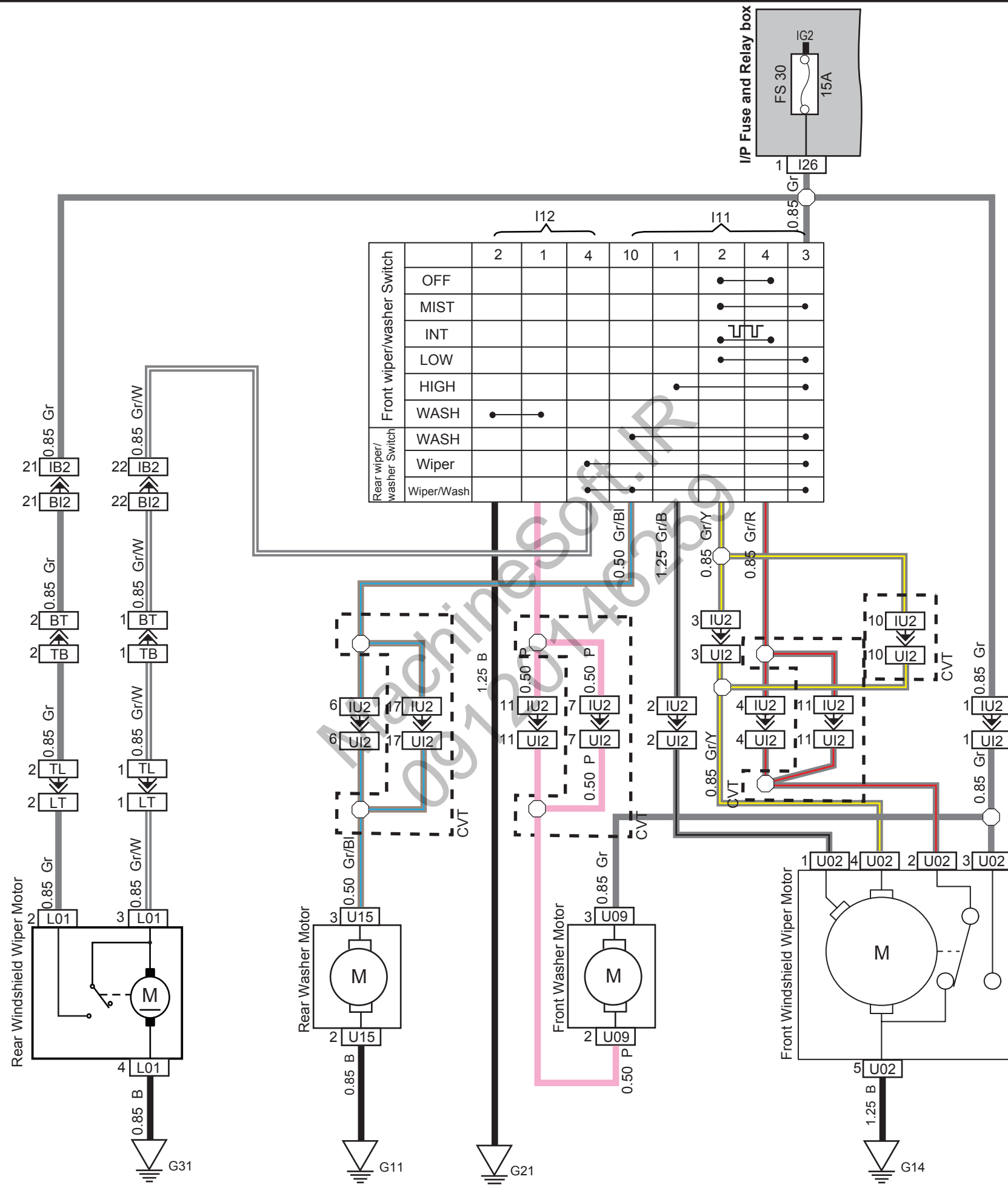

Central Locking / Theft Deterrent System

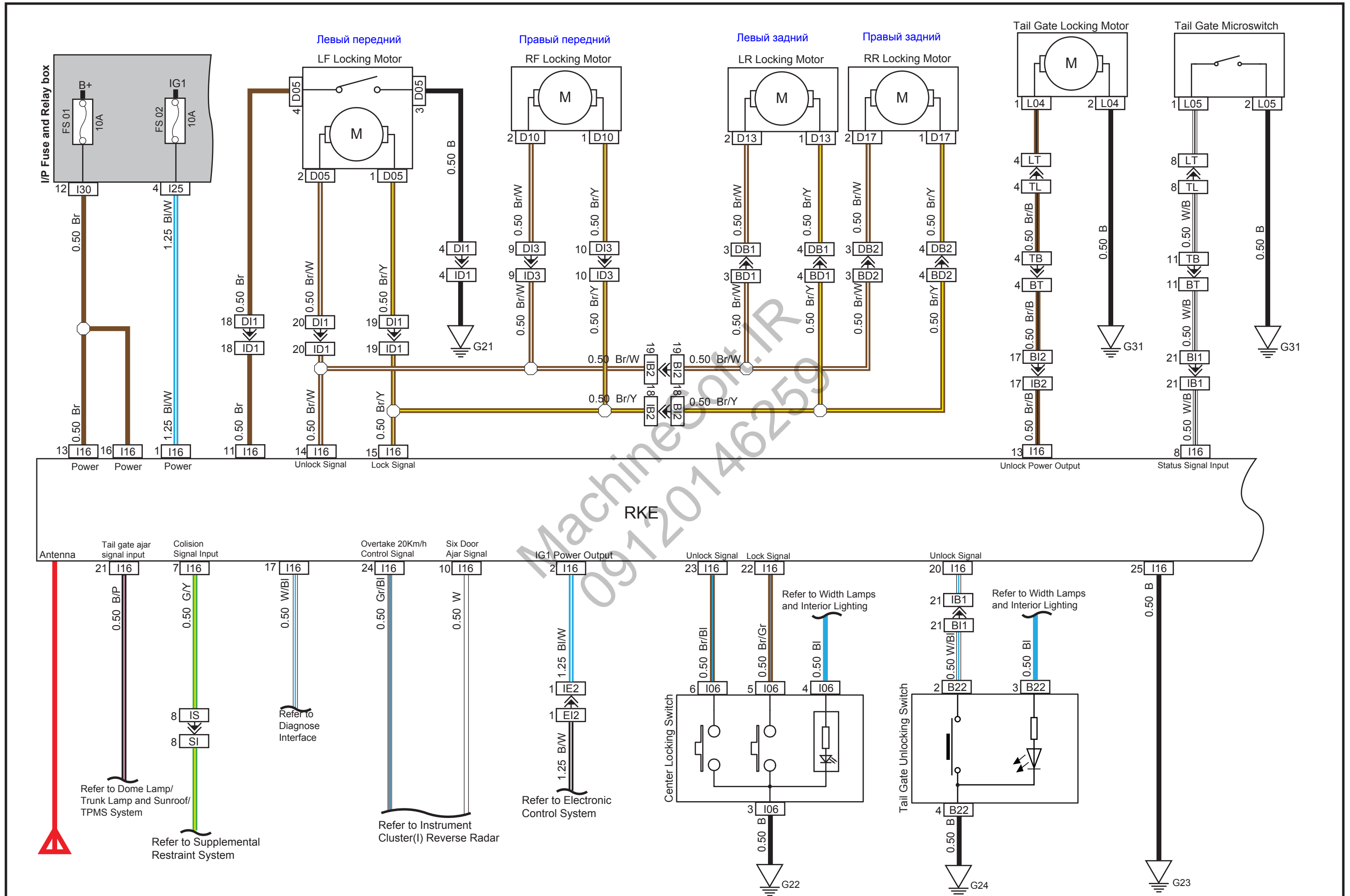

Supplemental Restraint System

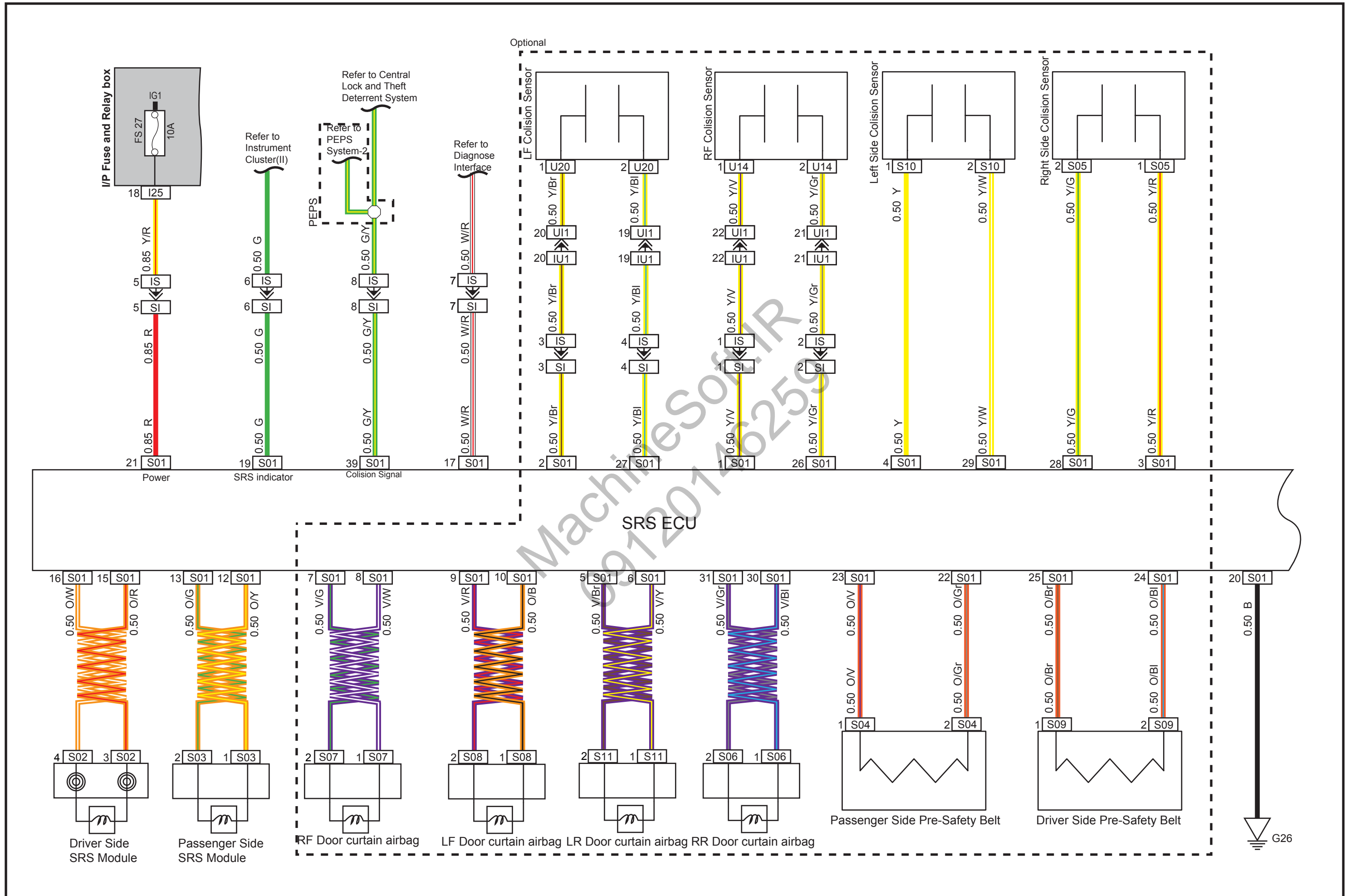

PEPS System-1

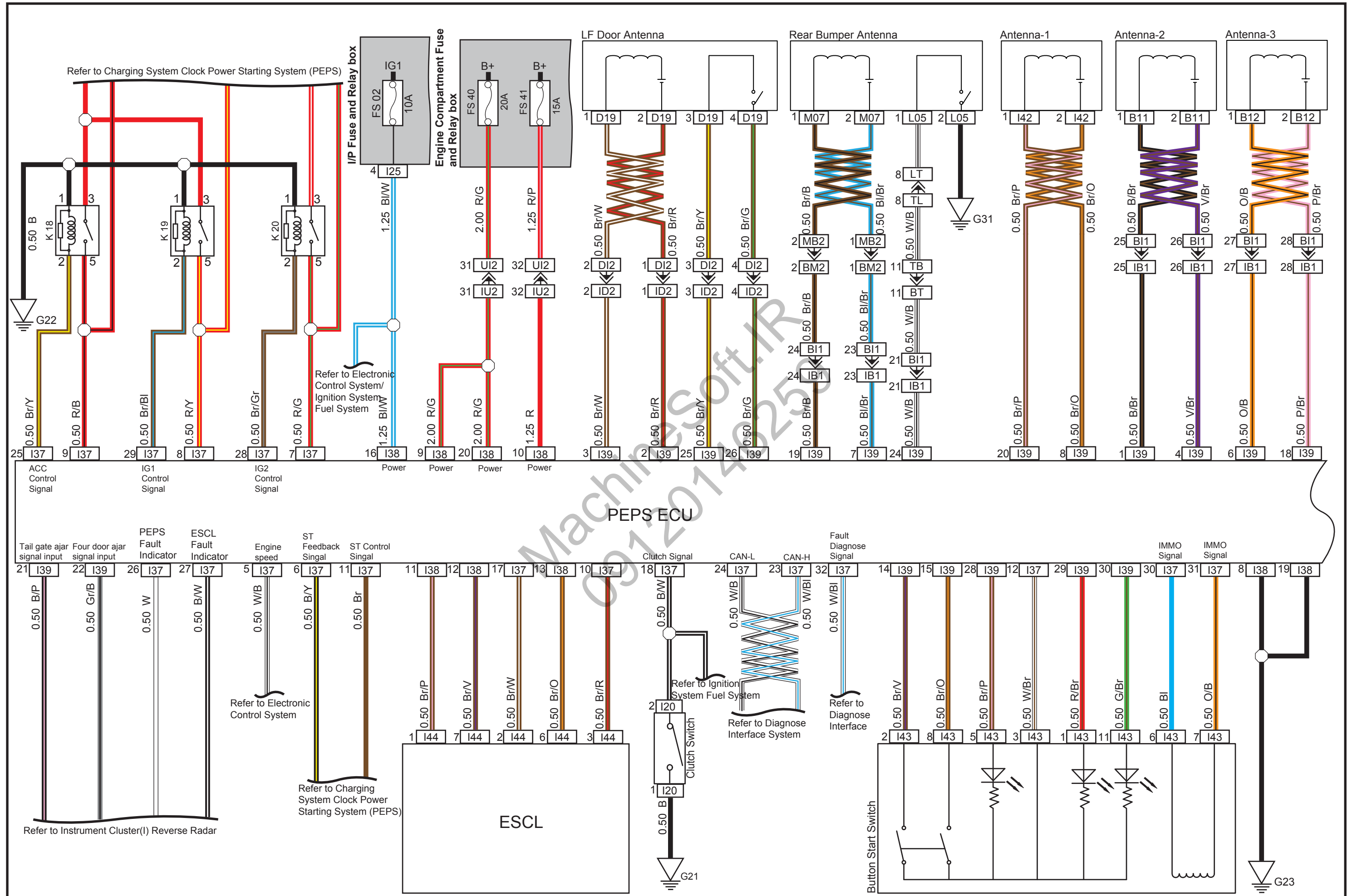

PEPS System-2

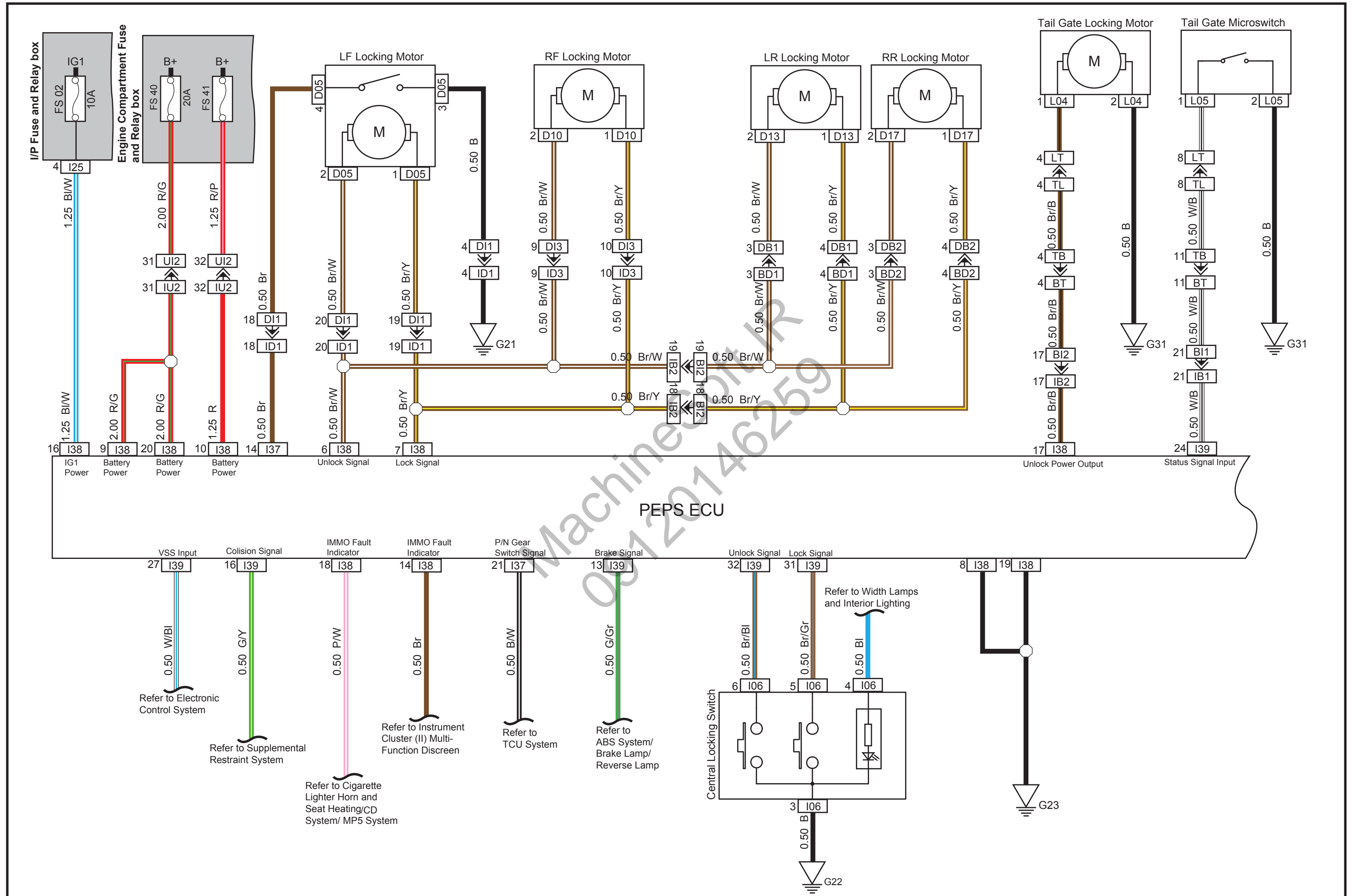

ESP System

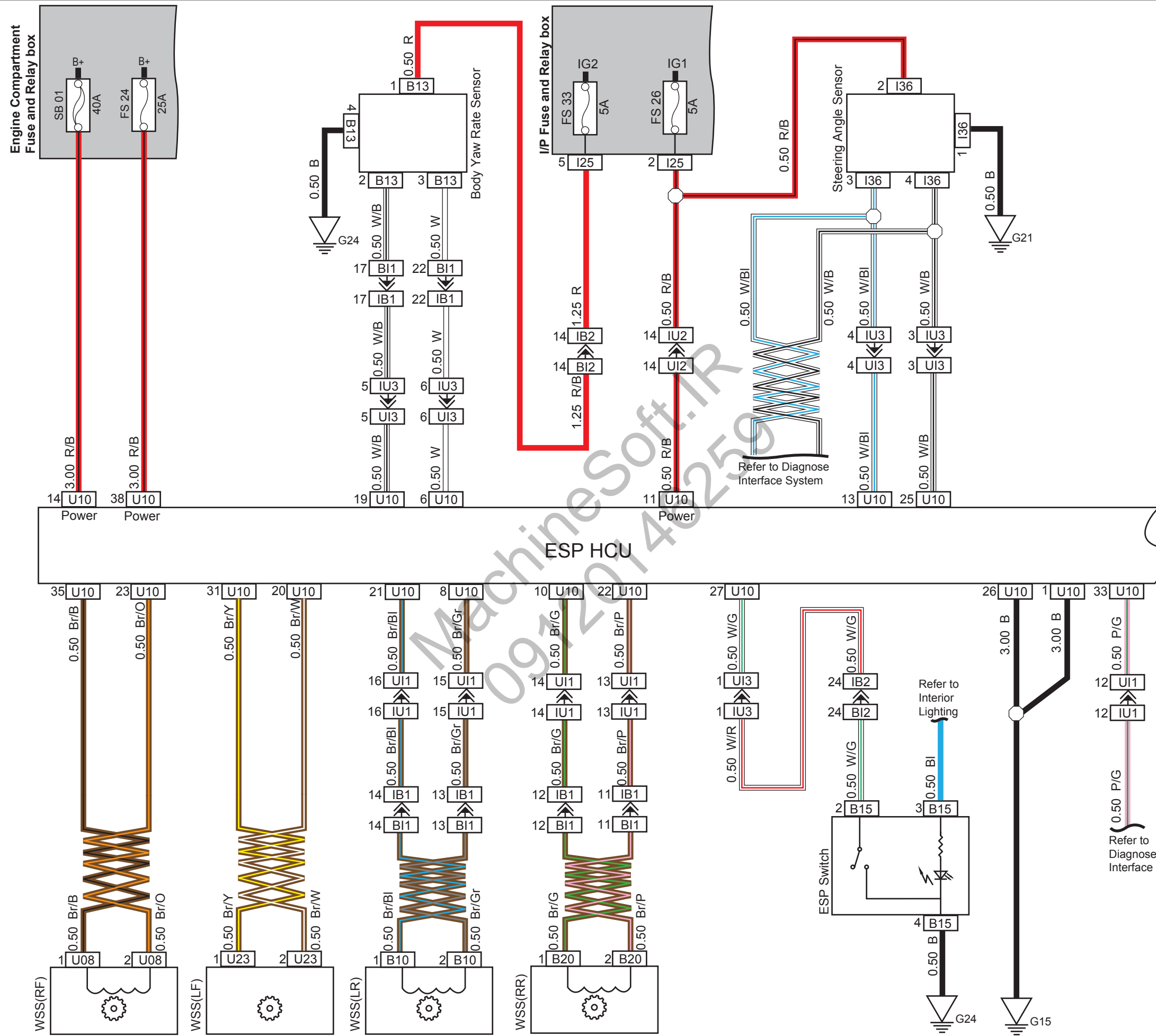

ABS System / Brake Lamp / Reverse Lamp

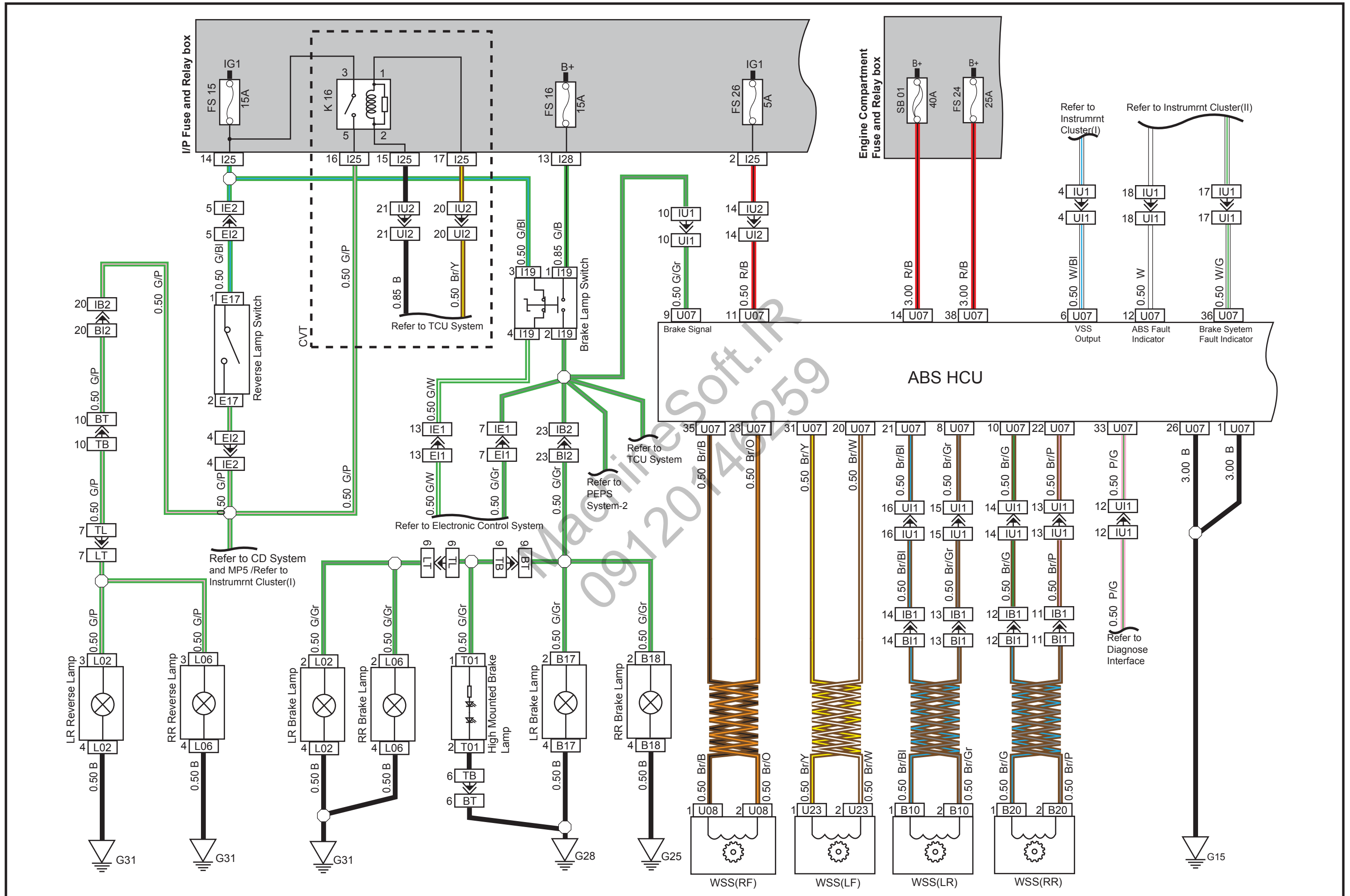

Diagnose Interface System

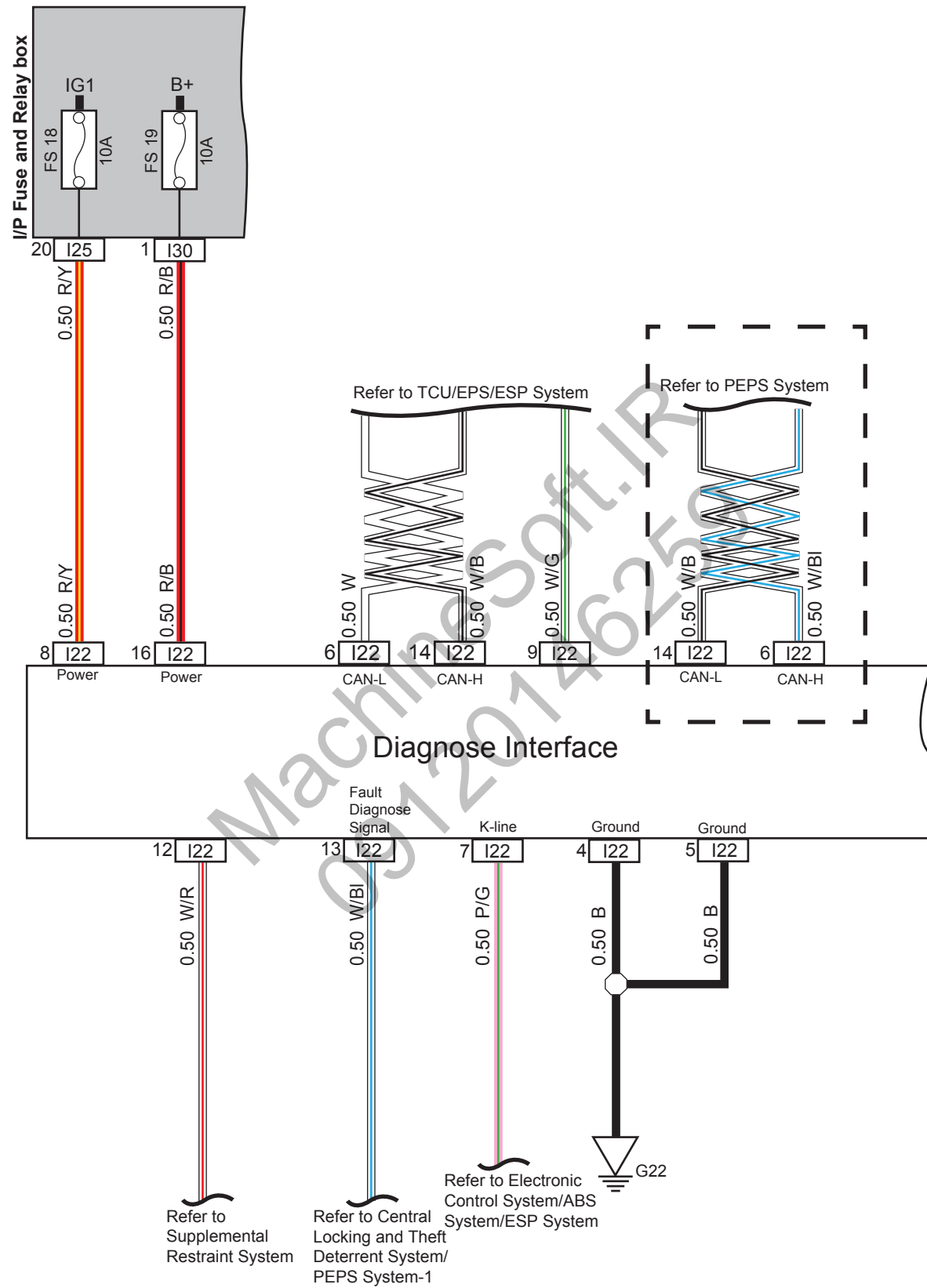

Engine Compartment Fuse and Relay Box

Engine Compartment Fuse and Relay Box

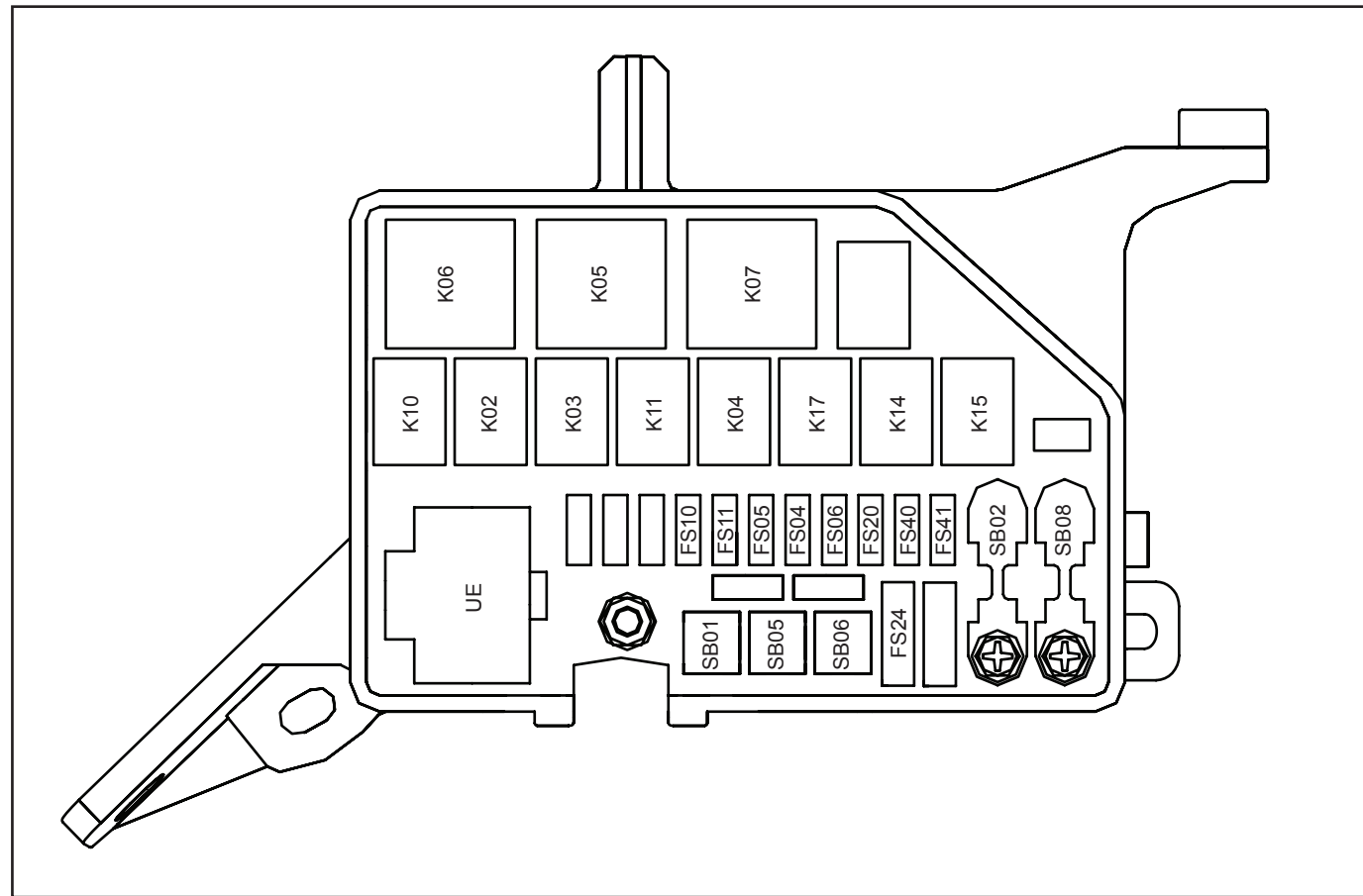

Fuse

Code	Application	Rated Current (A)	Description
FS04	Main Relay Fuse	25A	
FS05	Fuel Pump Fuse	15A	
FS06	Air Conditioning Fuse	10A	
FS10	Low Beam Lamp Fuse	15A	
FS11	High Beam Lamp Fuse	15A	
FS14	Front Fog Lamp Fuse	15A	
FS20	Horn Fuse	15A	
FS24	ABS ECU Fuse	25A	
FS40	PEPS Fuse	20A	
FS41	ESCL Fuse	15A	
SB01	ABS ECU Fuse	40A	
SB02	IP Power Box Fuse	60A	
SB05	High Speed Fan Fuse	25A	
SB06	Low Speed Fan Fuse	25A	
SB08	EPS ECU Fuse	60A	

Relay

Code	Application	Description
K02	High Beam Lamp Relay	
K03	Fuel Pump Relay	
K04	Air Conditioning Compressor Relay	
K05	Adjusting Speed Fan Relay	
K06	High Speed Fan Relay	
K07	Low Speed Fan Relay	
K10	Low Beam Lamp Relay	
K11	Main Relay	
K15	Daytime Running Lamp Relay	
K17	Horn Relay	
K18	ACC Relay	
K19	IG1 Relay	
K20	IG2 Relay	

IP Fuse and Relay Box

IP Fuse and Relay Box

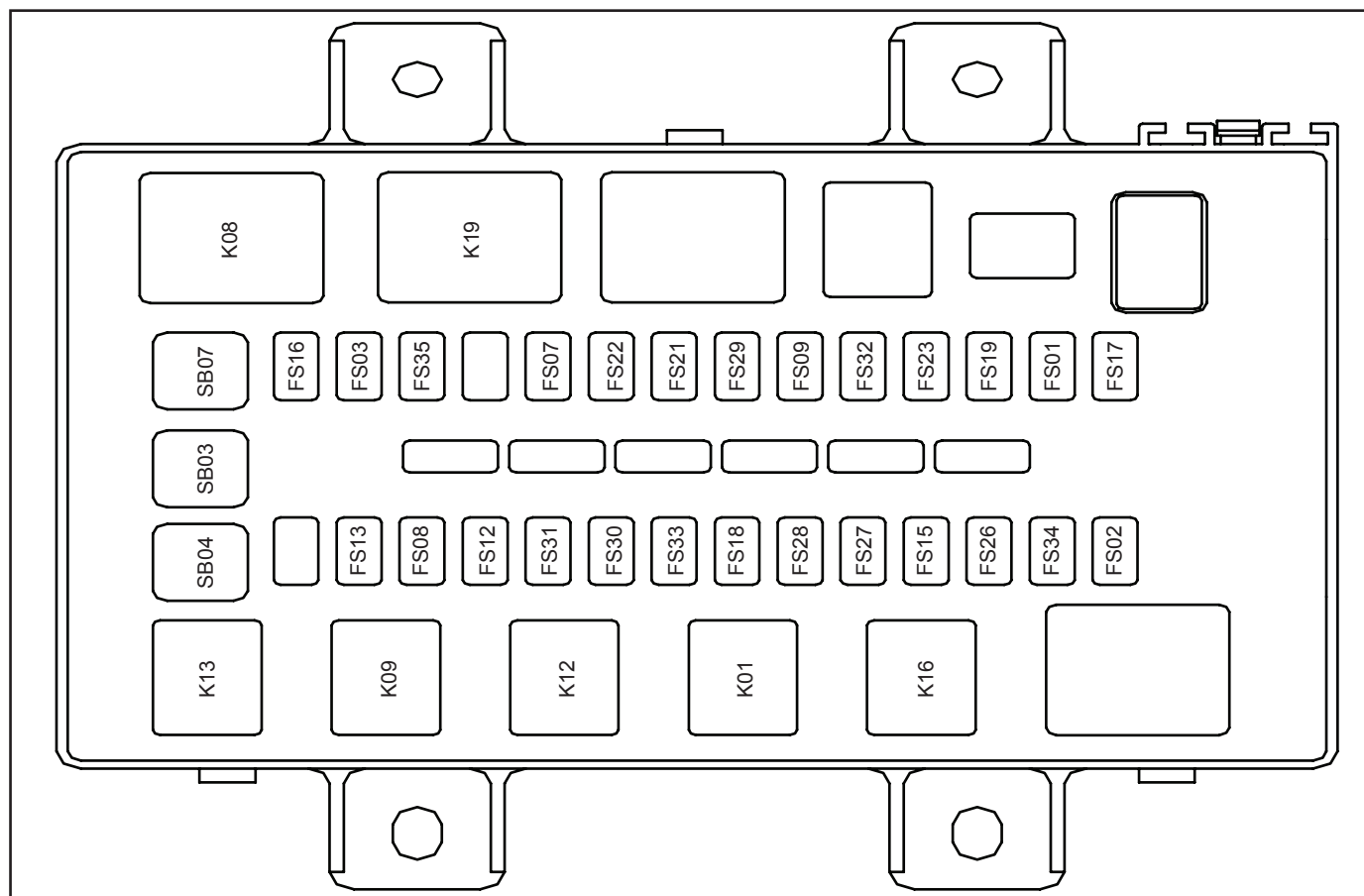

Fuse

Code	Application	Rated Current (A)	Description
FS01	IMMO ECU / Central Locking Fuse	15A	
FS02	Generator / IMMO ECU/Central Locking Fuse	10A	
FS03	ECU Fuse	15A	
FS07	Air Conditioning Fuse	10A	
FS08	Rear Defroster Fuse	25A	
FS09	Power Window Fuse	30A	
FS12	Width Lamp Fuse	10A	
FS13	Rear Fog Lamp Fuse	10A	
FS15	Reverse Lamp / Brake Lamp / Daytime Running Lamp Fuse	10A	
FS16	Brake Lamp Fuse	10A	
FS17	Dome Lamp Fuse	5A	
FS18	Instrument Cluster Fuse	10A	
FS19	Instrument Cluster Fuse	10A	
FS21	Cigarette Lighter Fuse	15A	
FS22	CD Fuse	10A	
FS23	CD Fuse	15A	
FS26	ABS ECU Fuse	5A	
FS27	SRS ECU Fuse	10A	
FS28	EPS ECU Fuse	10A	
FS29	Power Rearview Mirror Fuse	10A	
FS30	Wiper Fuse	15A	
FS31	Sunroof Fuse	5A	
FS32	Sunroof Fuse	15A	
FS33	Seat Heating Fuse	15A	
FS34	TCU Fuse	10A	CVT
FS35	TCU Fuse	20A	CVT
SB03	AM1 Fuse	30A	
SB04	AM2 Fuse	30A	
SB07	Blower Fuse	30A	

Relay

Code	Application	Description
K01	Stator Relay	
K08	Blower Relay	
K09	Rear Defroster Relay	
K12	Width Lamp Relay	
K13	Rear Fog Lamp Relay	
K16	Reverse Lamp Relay	
K21	Power Relay	

IP Fuse and Relay Box

IP Relay Box(PEPS)

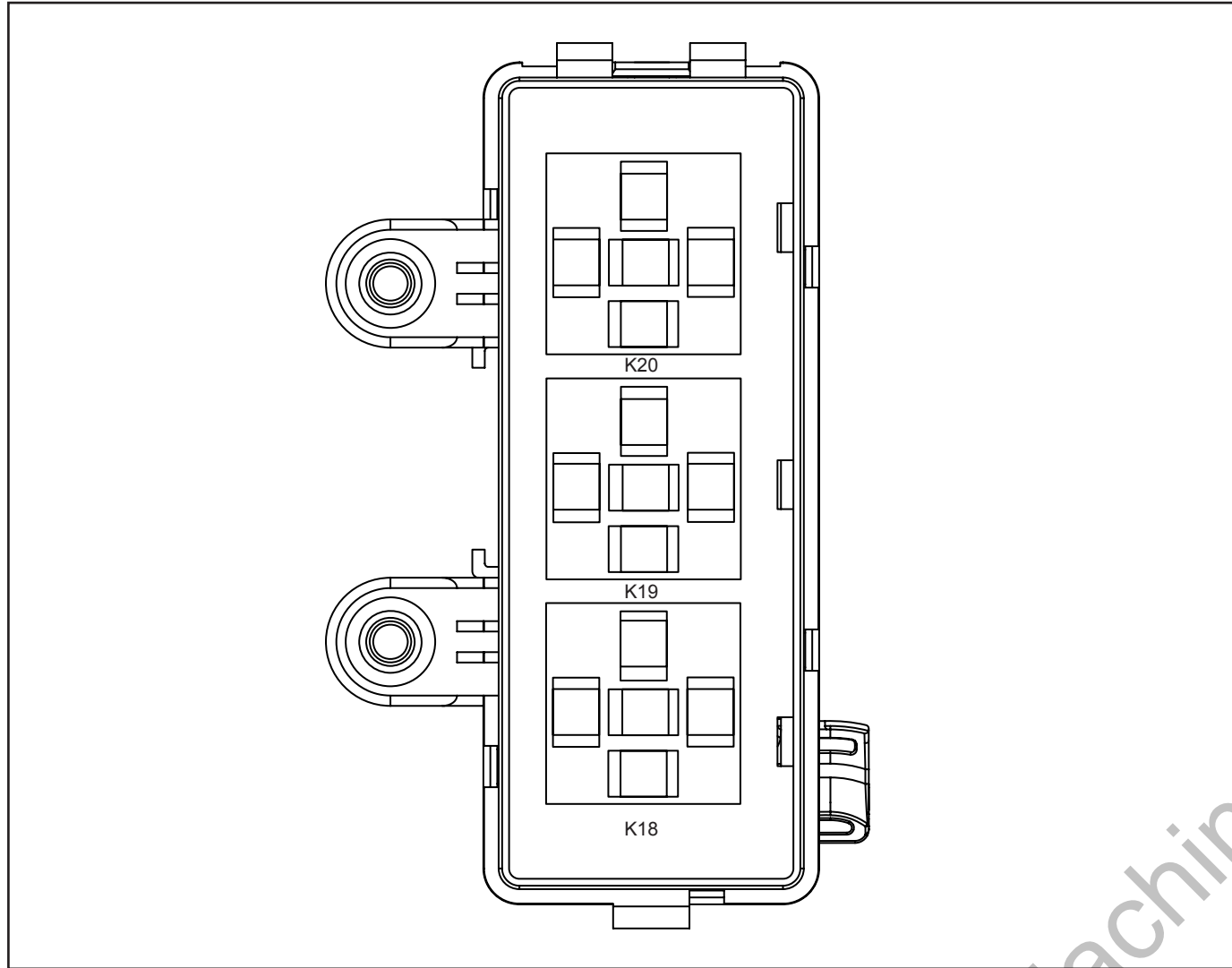

Relay

Code	Application	Description
K18	ACC Relay	
K19	IG1 Relay	
K20	IG2 Relay	

I/P Fuse and Relay Box Back View

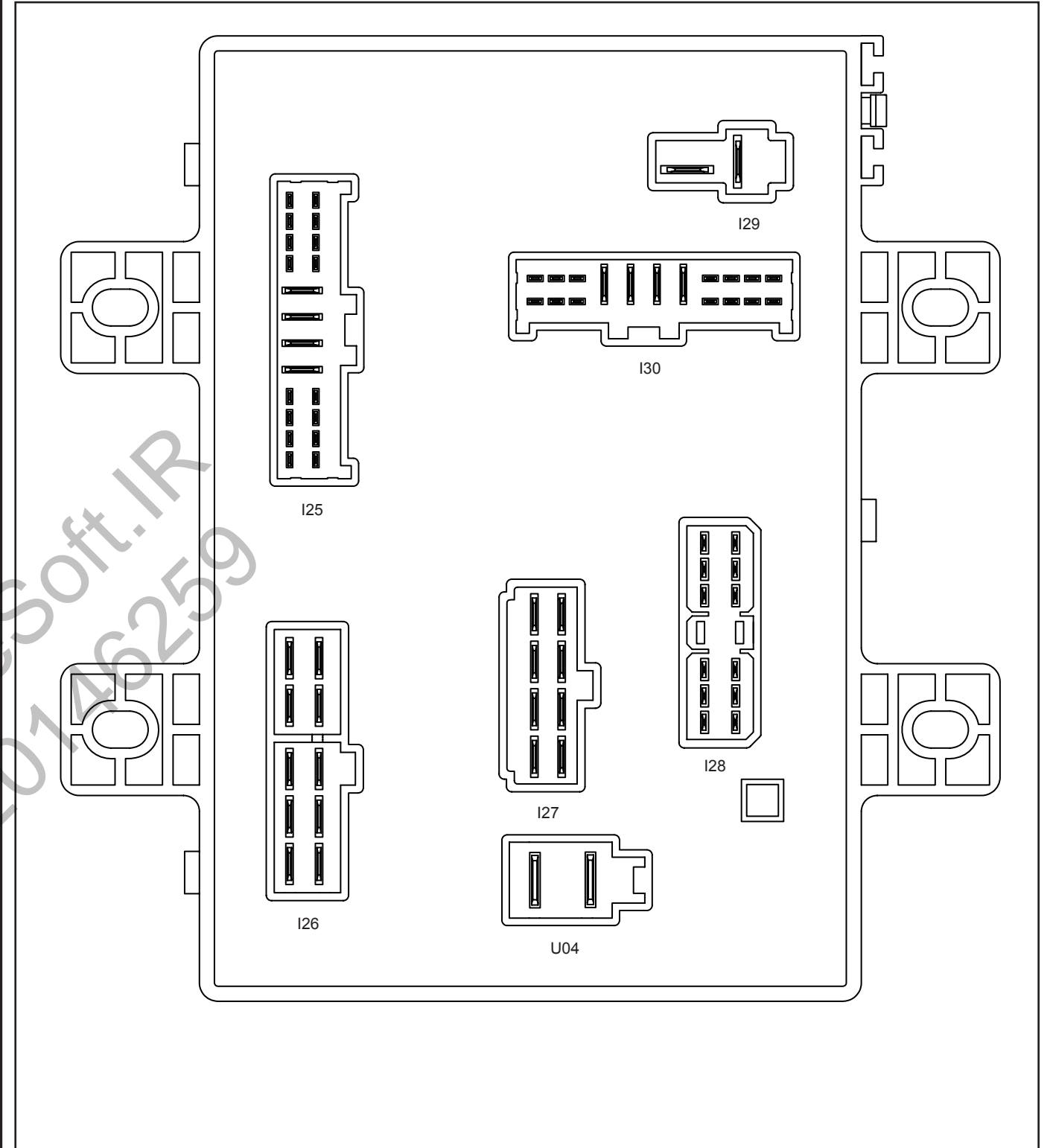

Engine Compartment Fuse and Relay Box Power Distribution

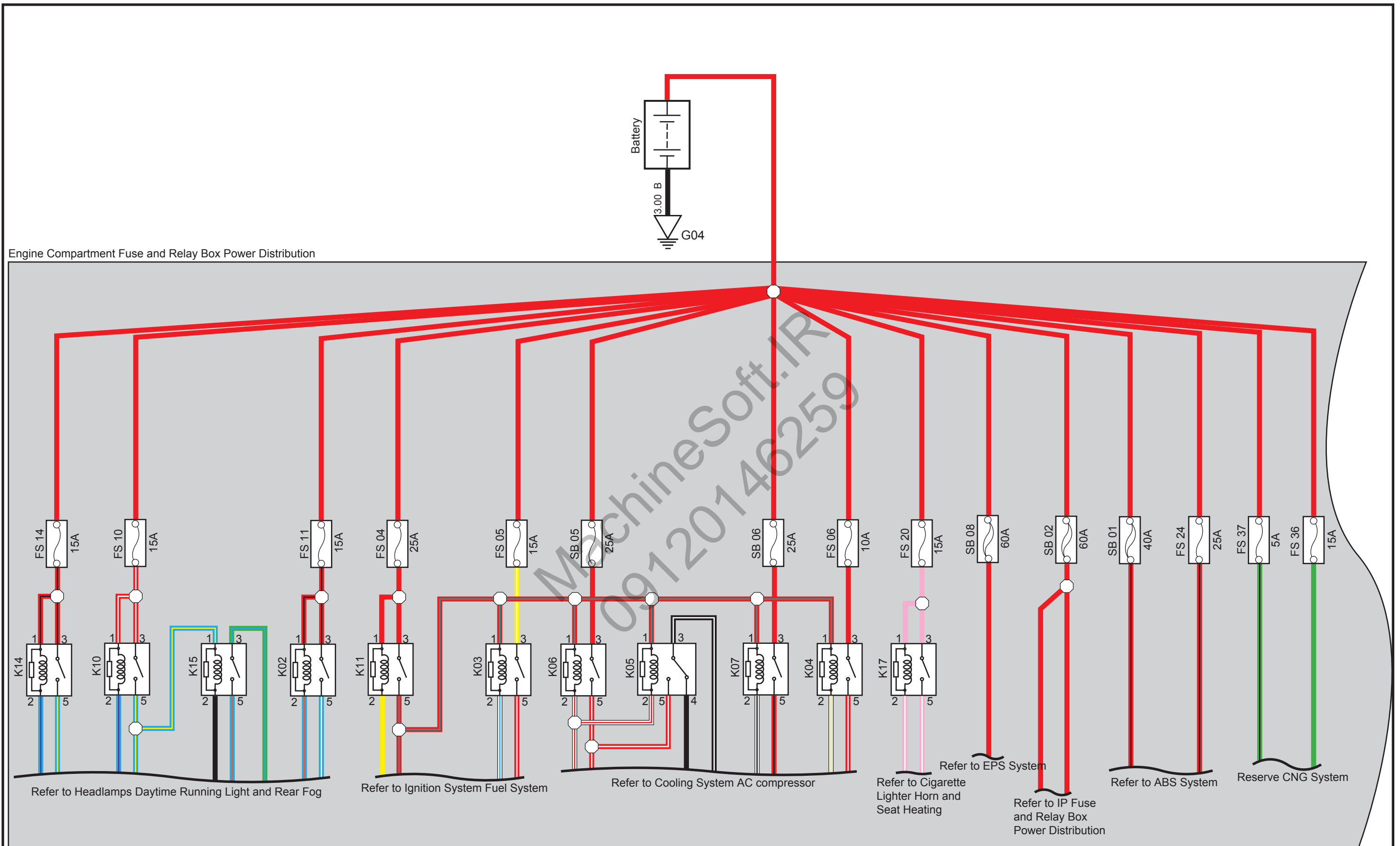

IP Fuse and Relay Box Power Distribution

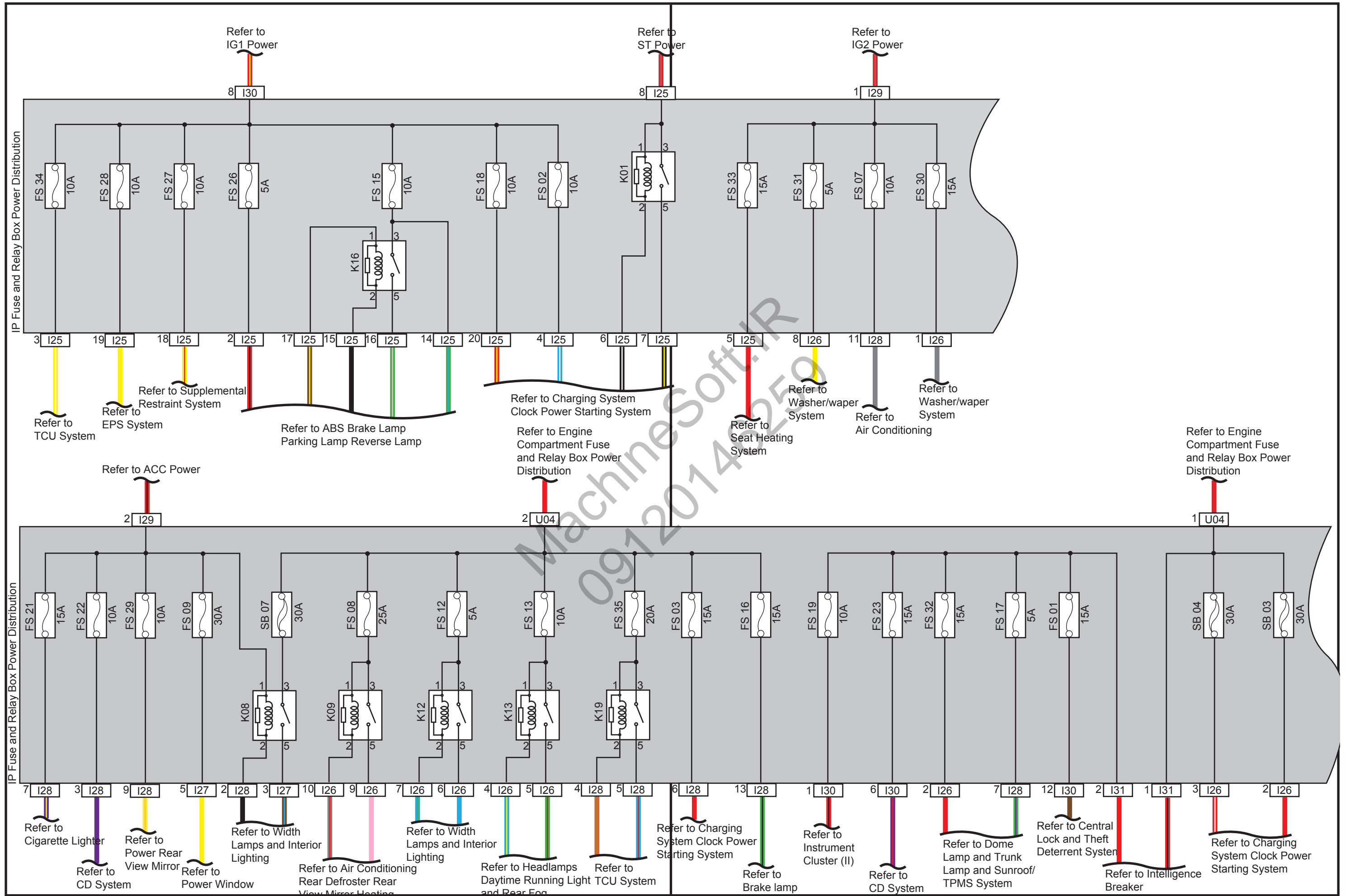

Ground Distribution G01-G02-G03-G04-G05

G01

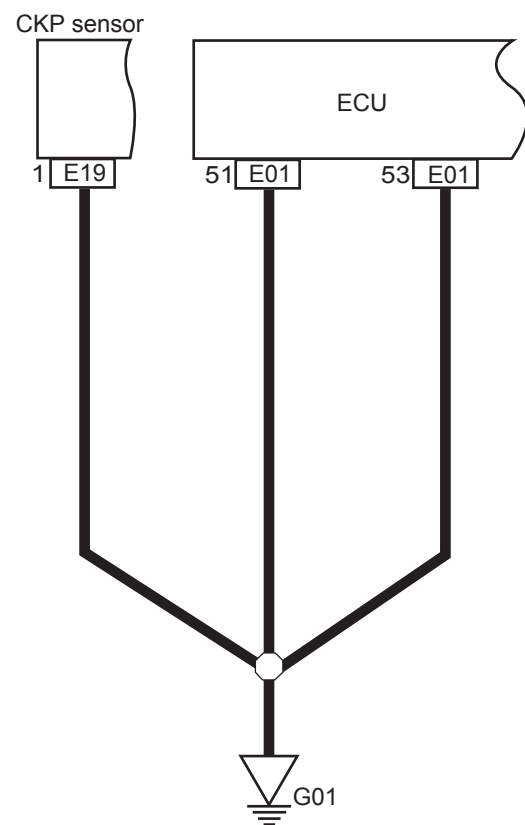

G03

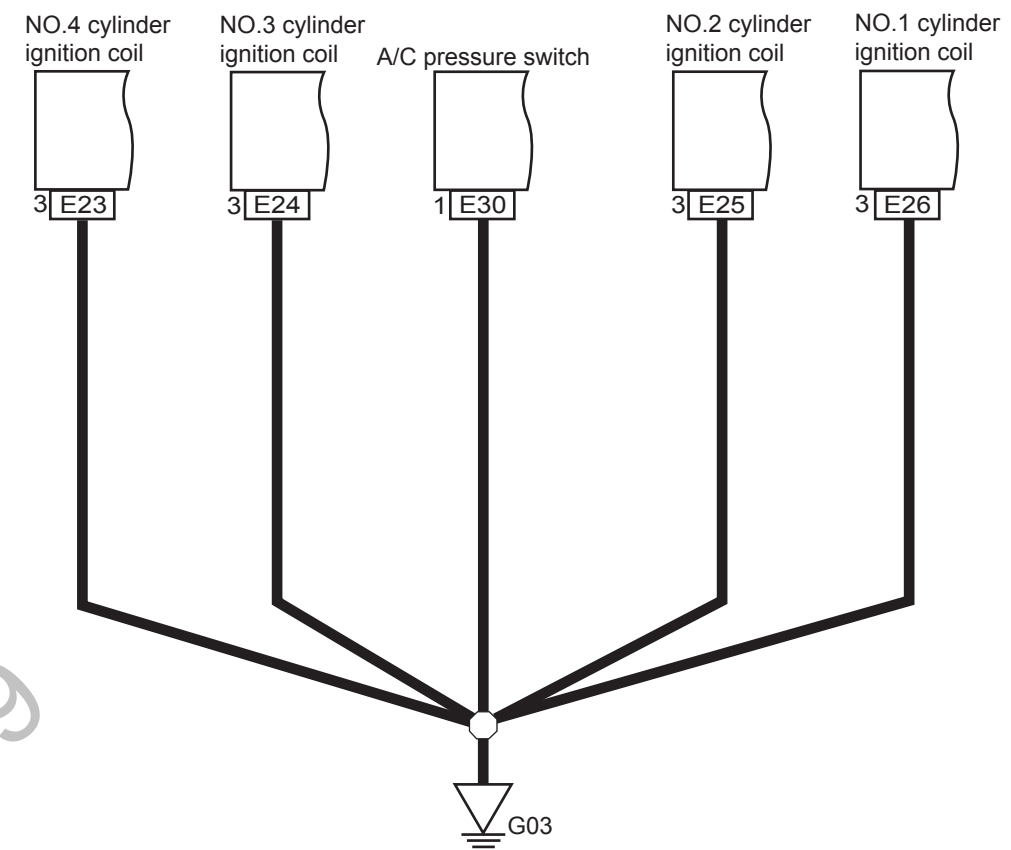

G02

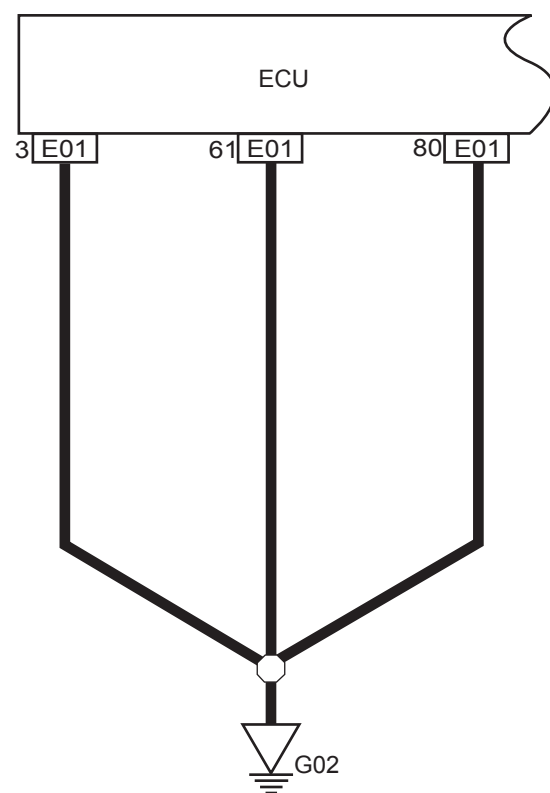

G04/G05

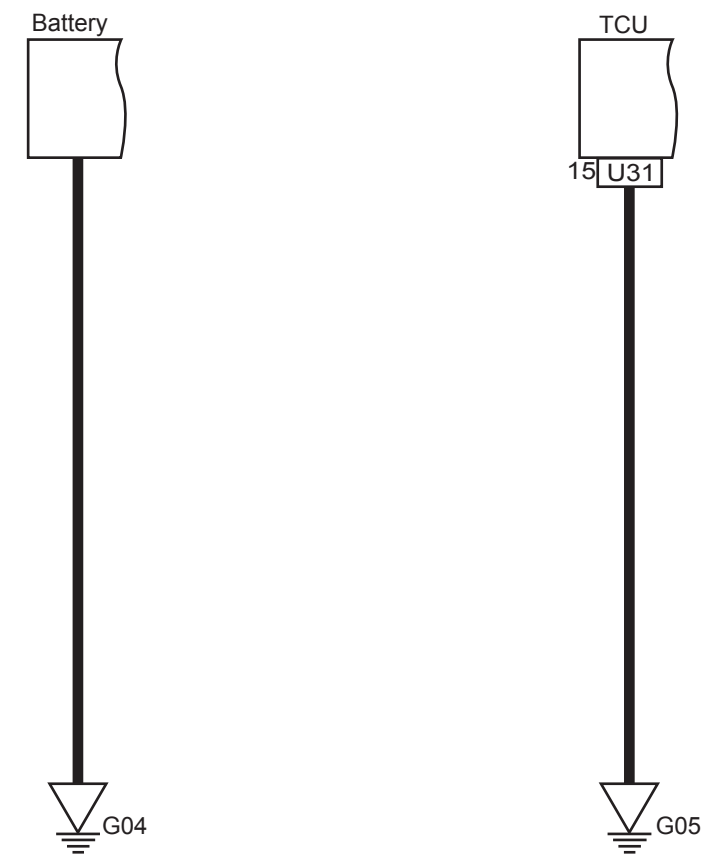

MachineSoft.IR
09120146259

Ground Distribution G11-G12-G13-G14

G11

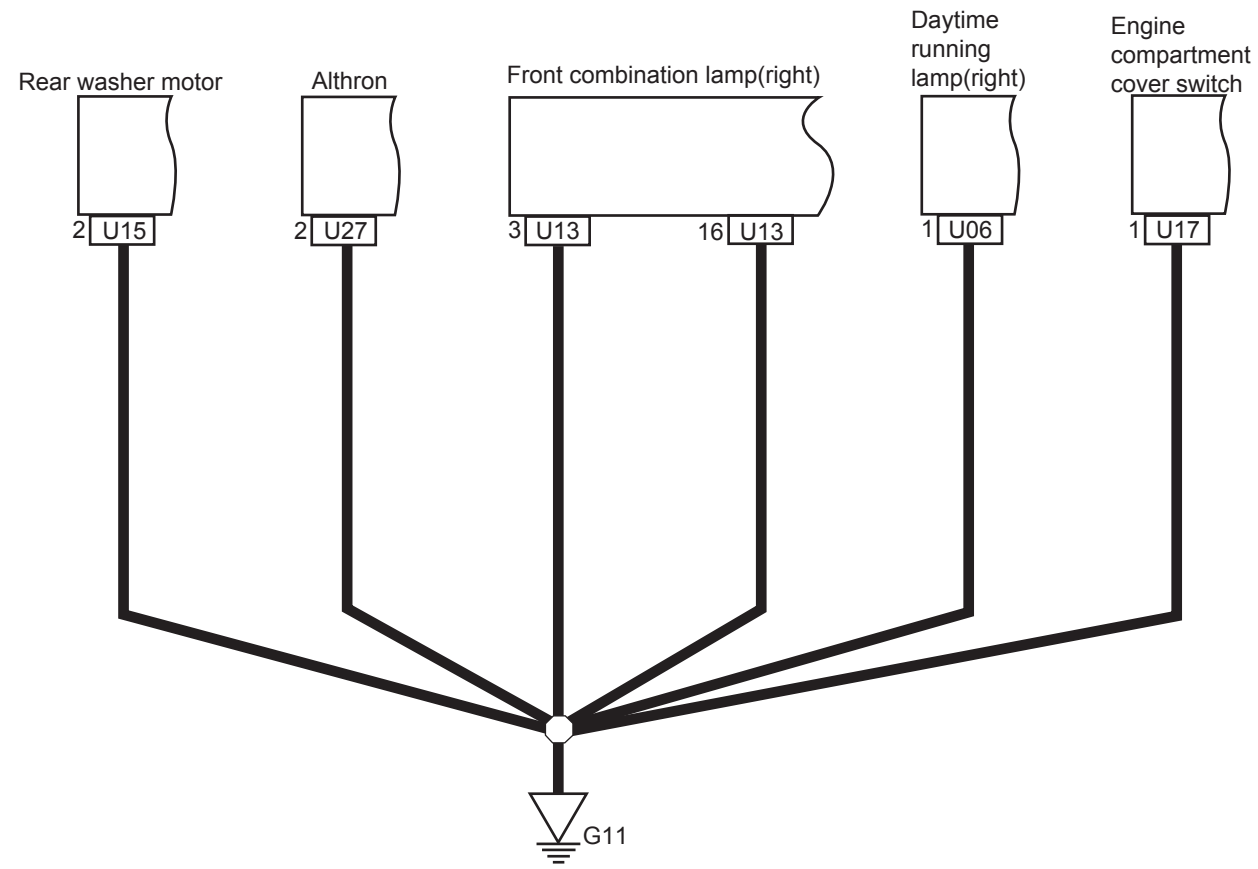

G13

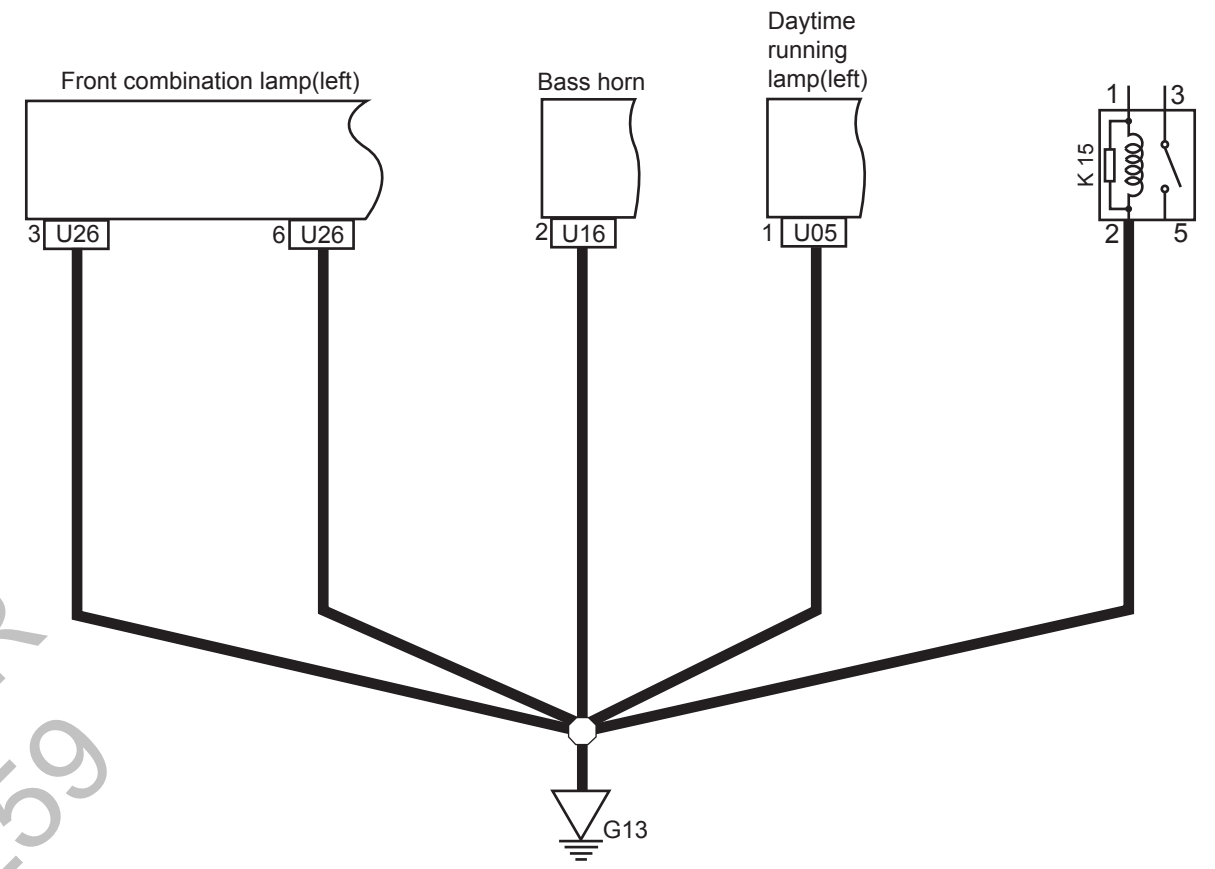

G12

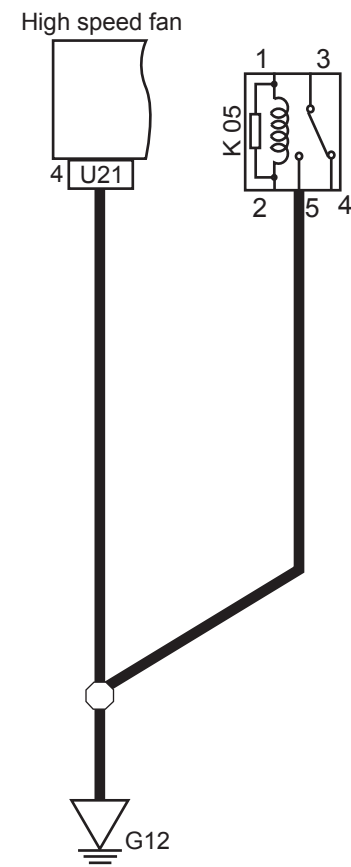

G14

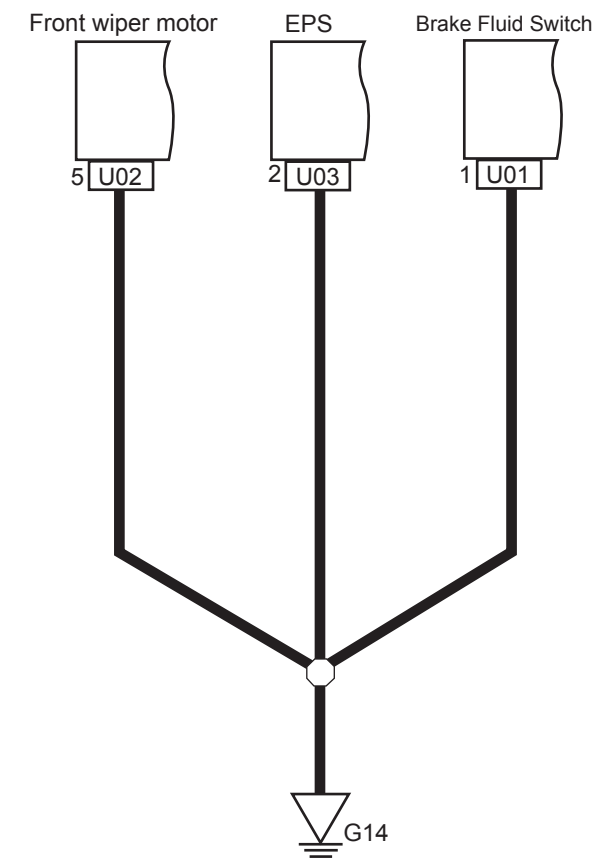

Ground Distribution G15-G21-G22

G15

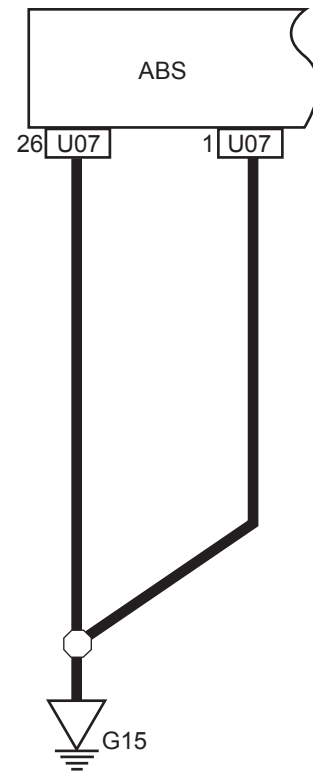

G22

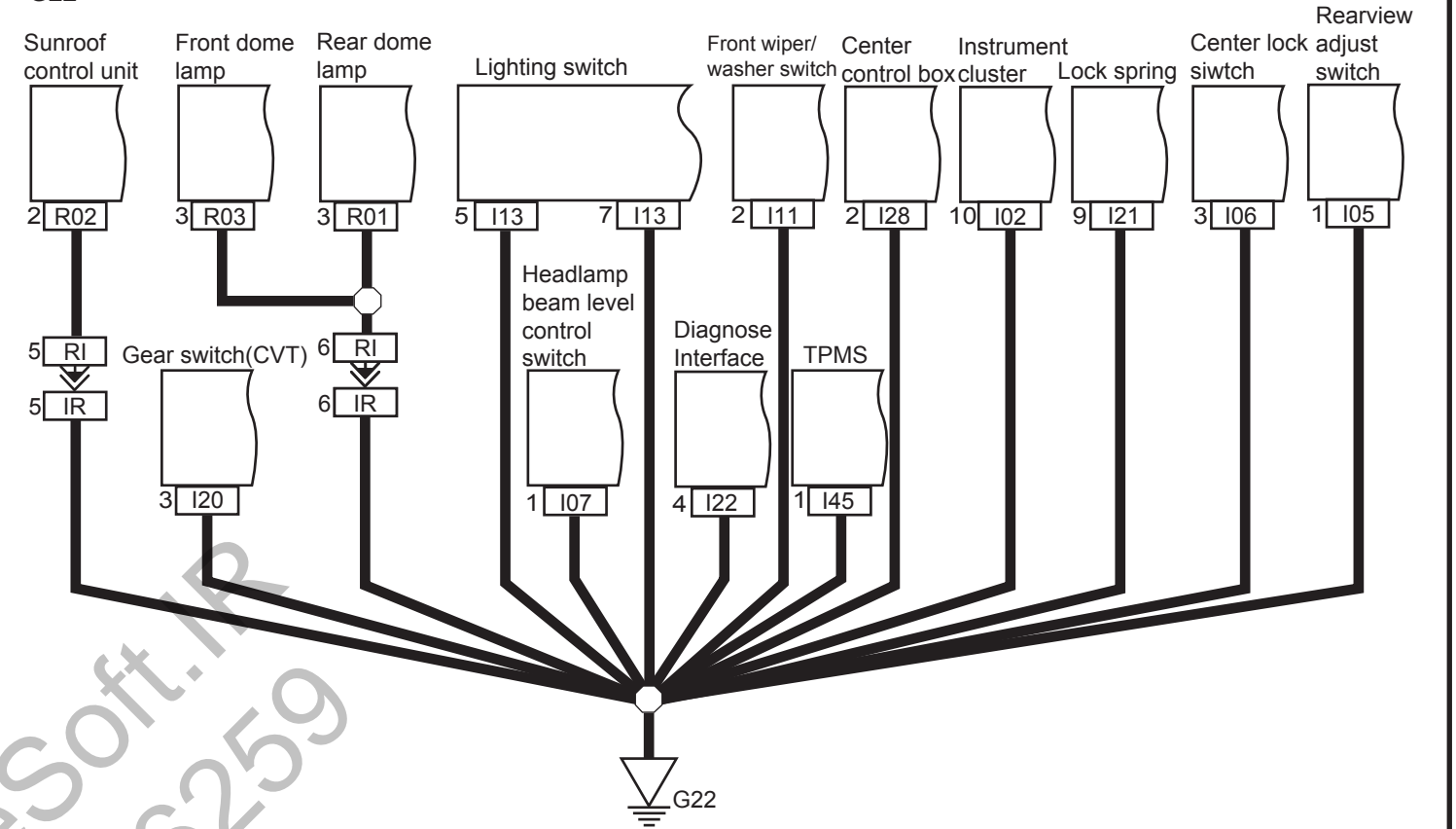

G21

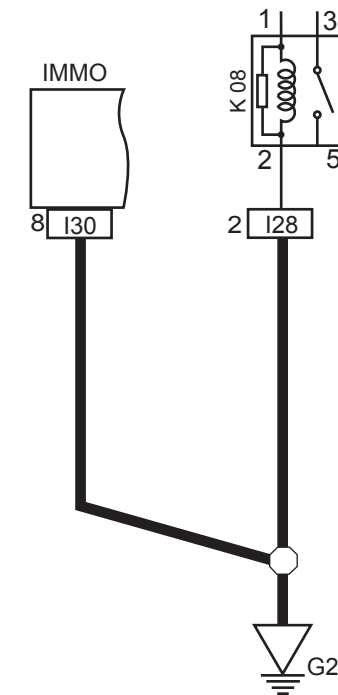
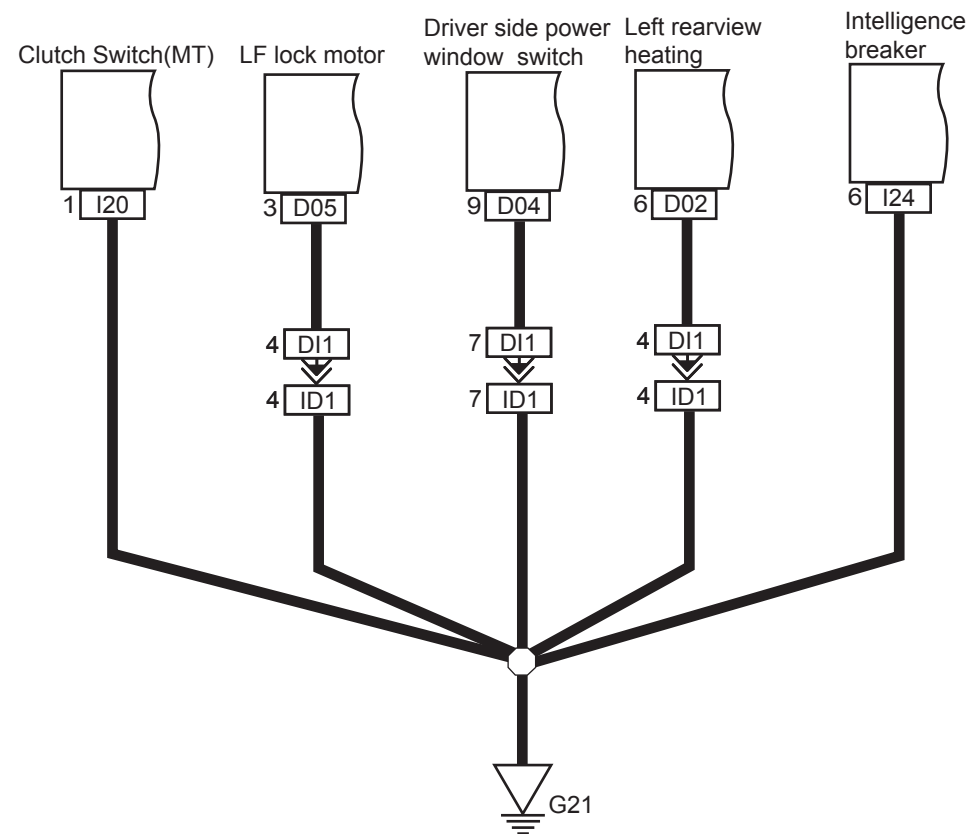

Ground Distribution G23-G24-G25

G23

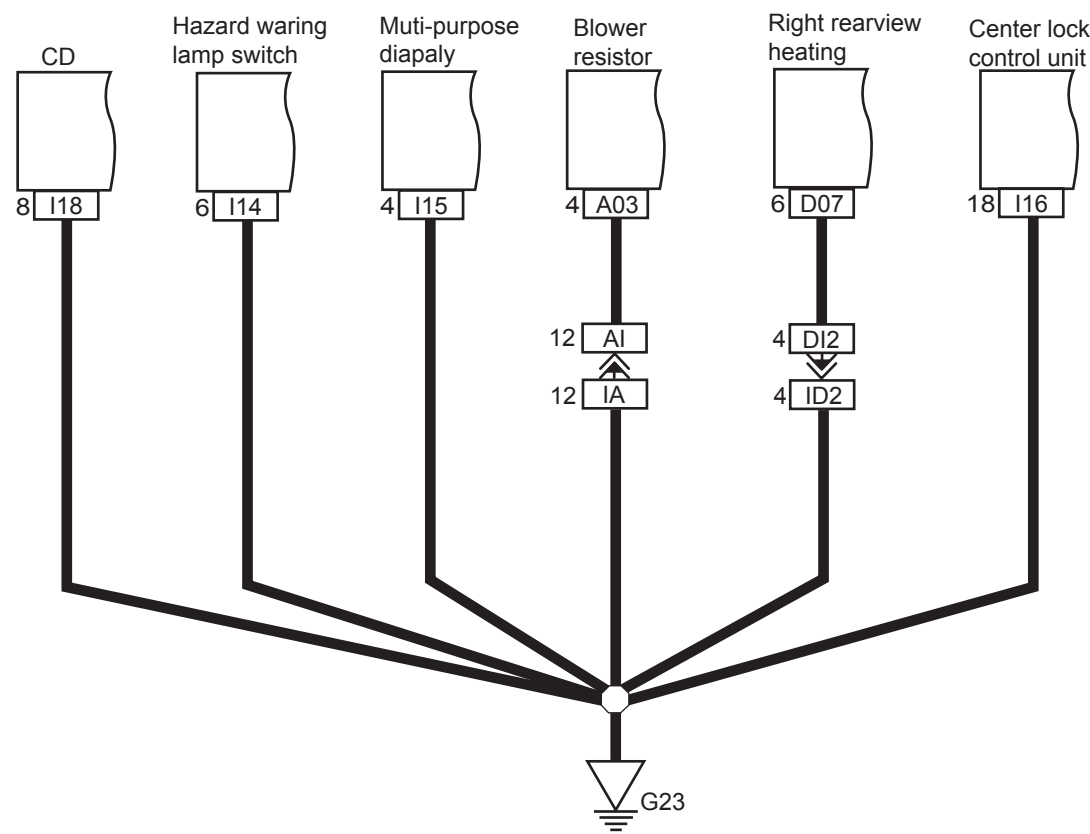

G24

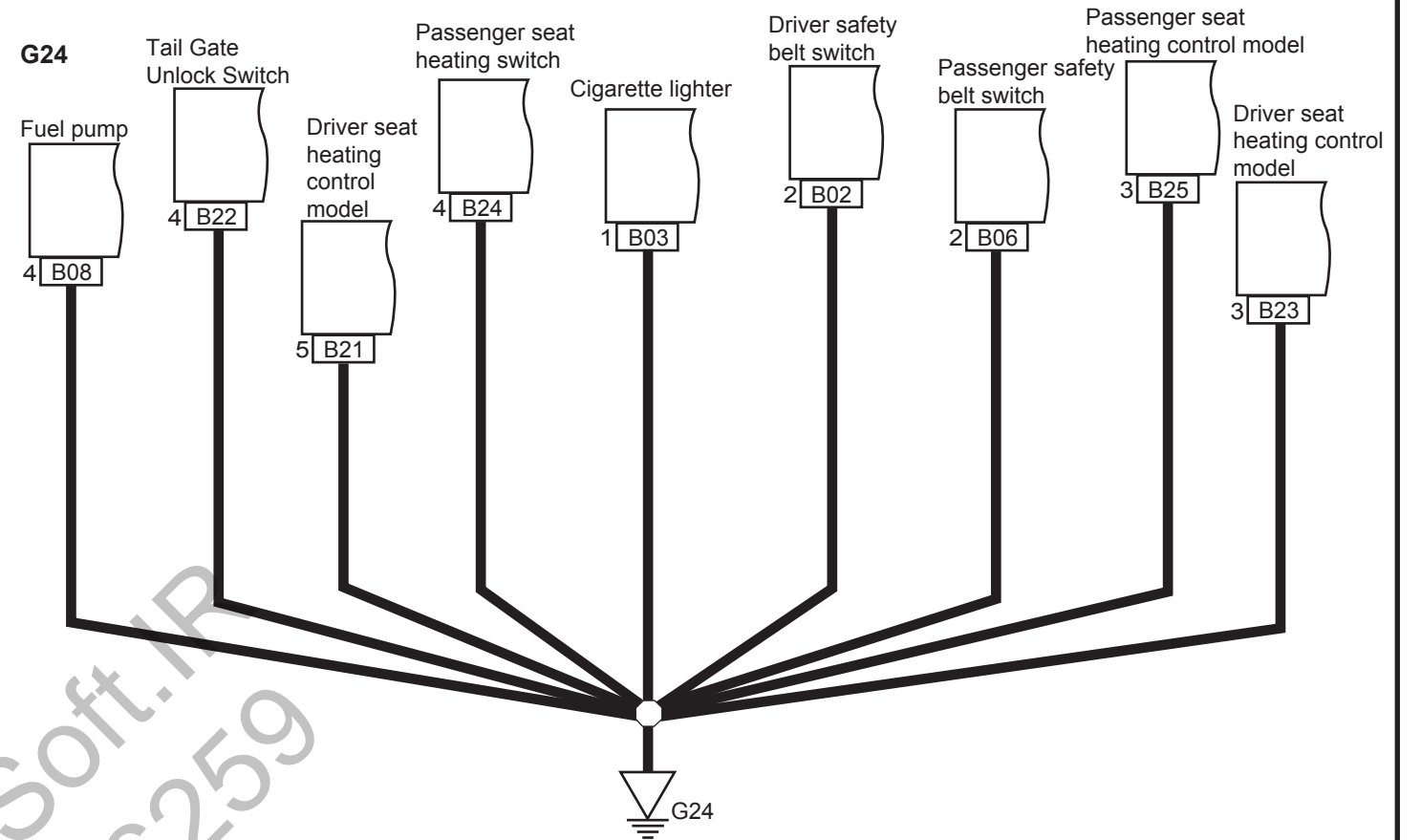

G25

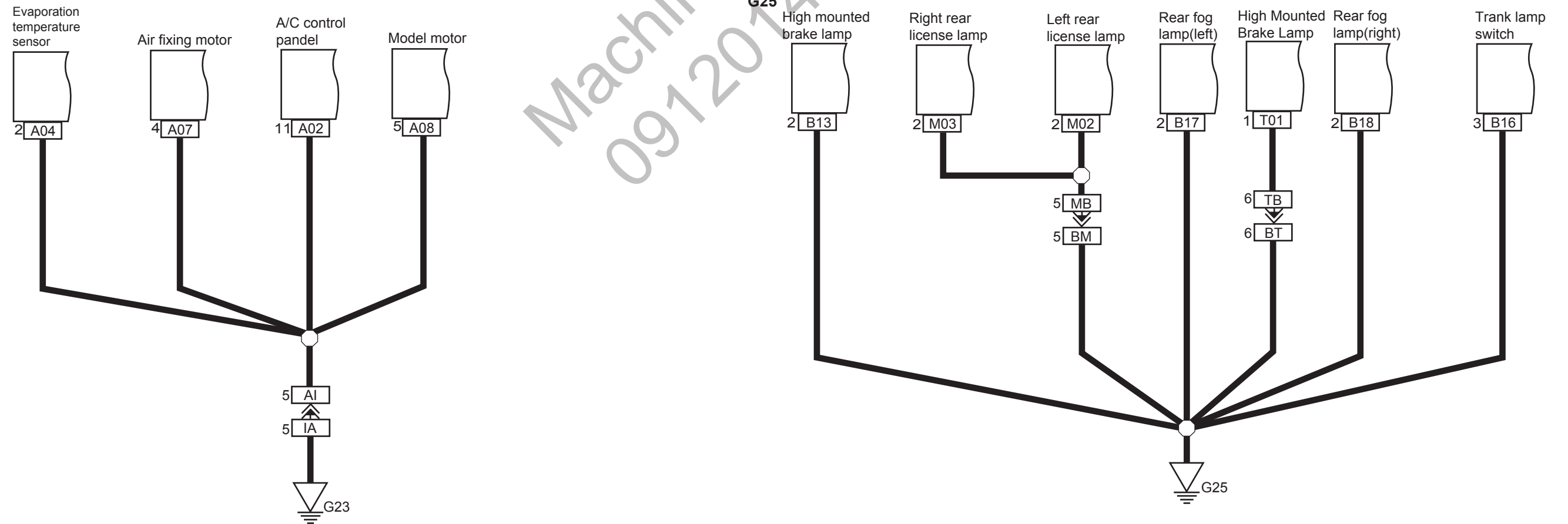

MachineSoft.P.R
09120146259

Ground Distribution G26-G27-G28-G31

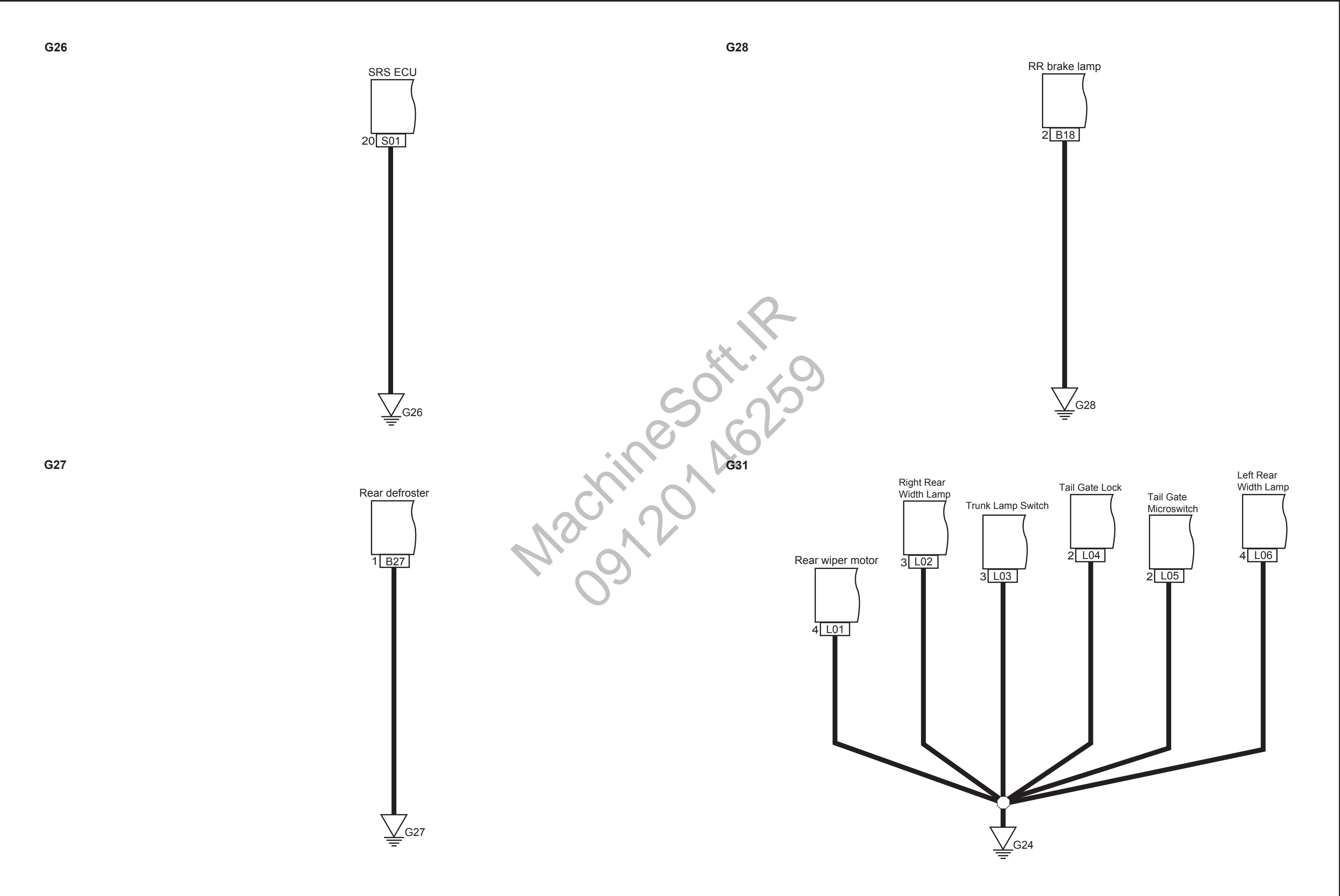

MachineSoft.IR
09120146259

Engine Harness Connector Location View

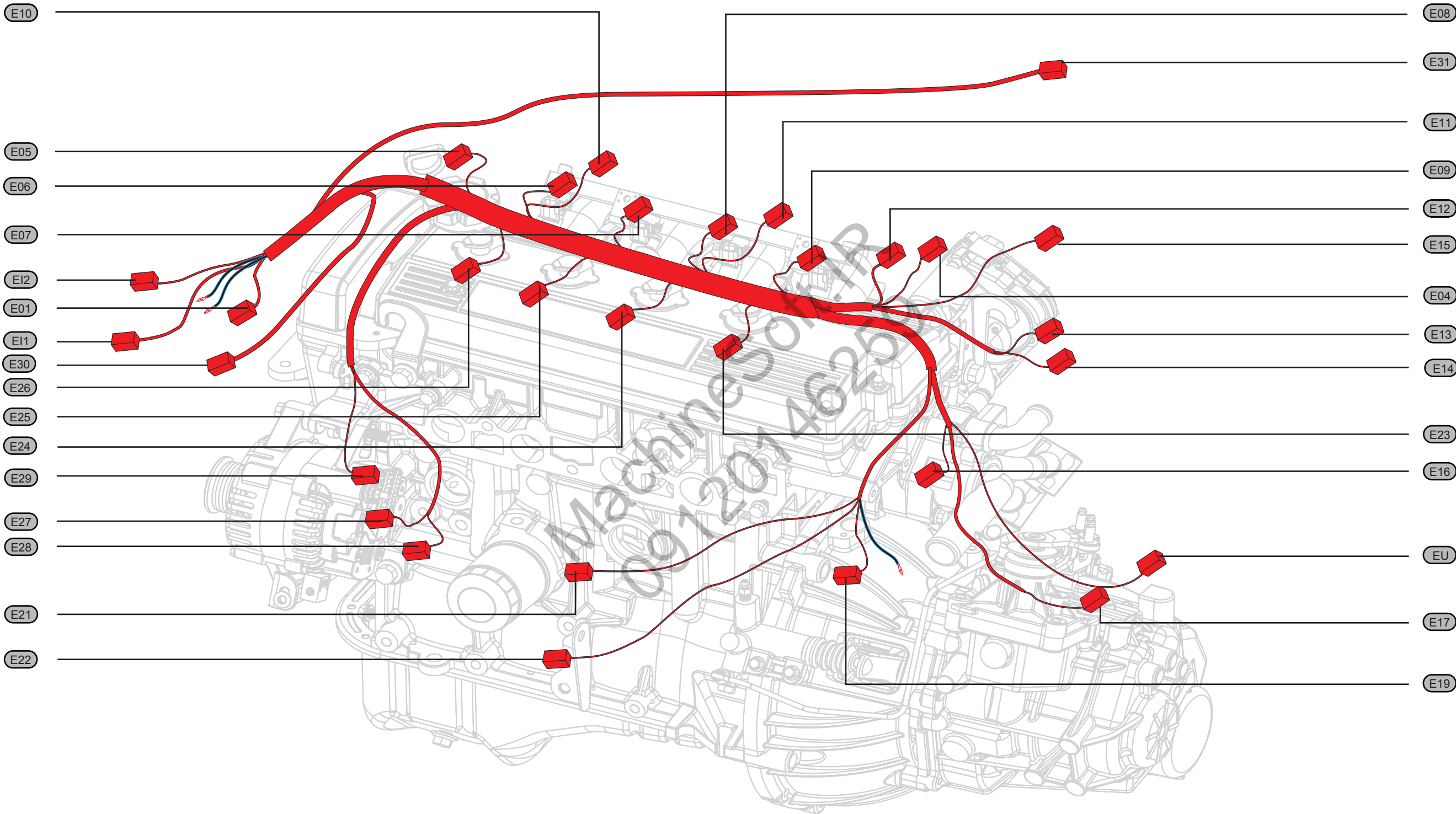

Engine Compartment Harness Connector Location View

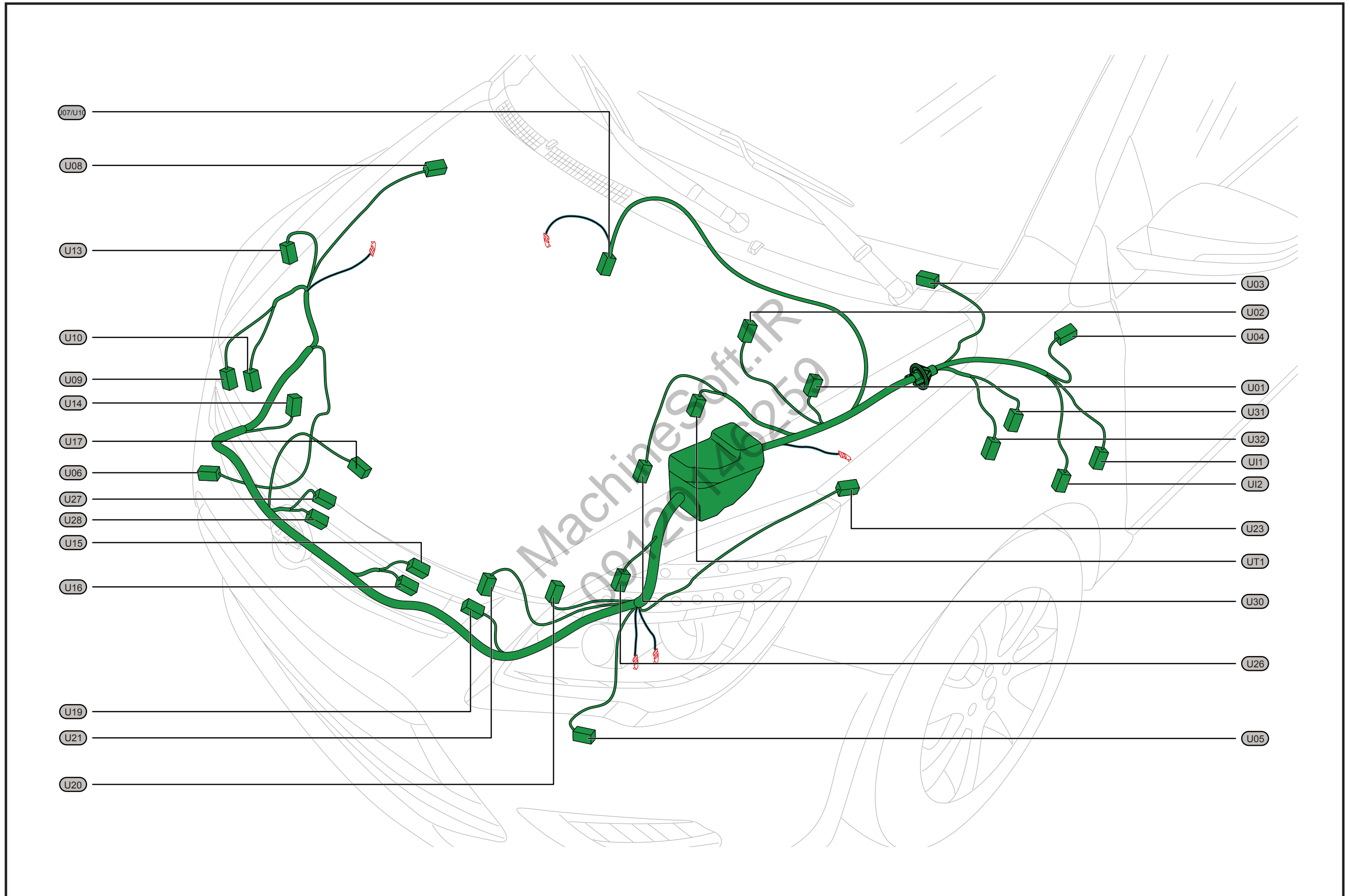

IP Harness Connector Location View

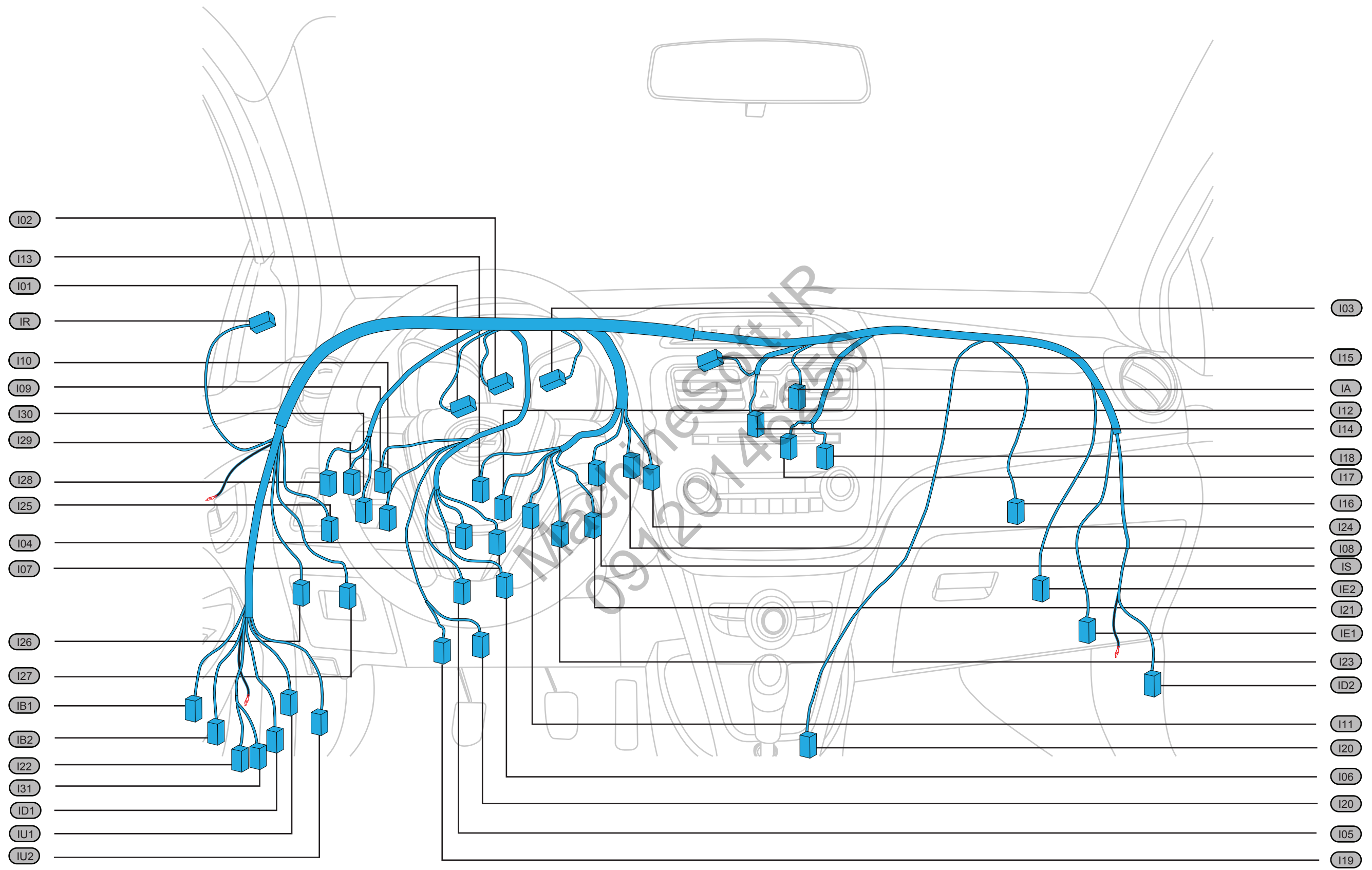

Body Harness Connector Location View

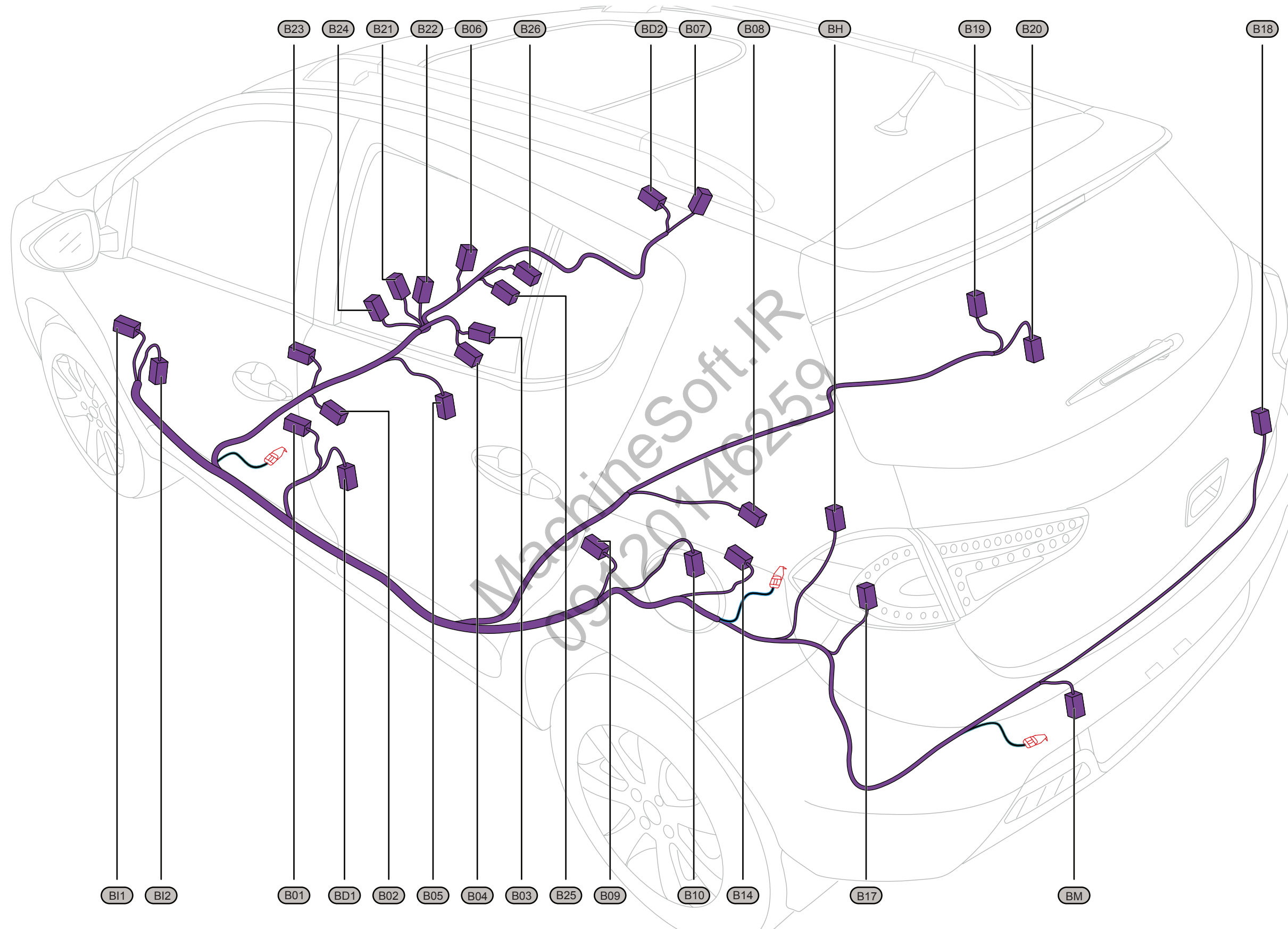

Door Harness Connector Location View

LF Door Harness

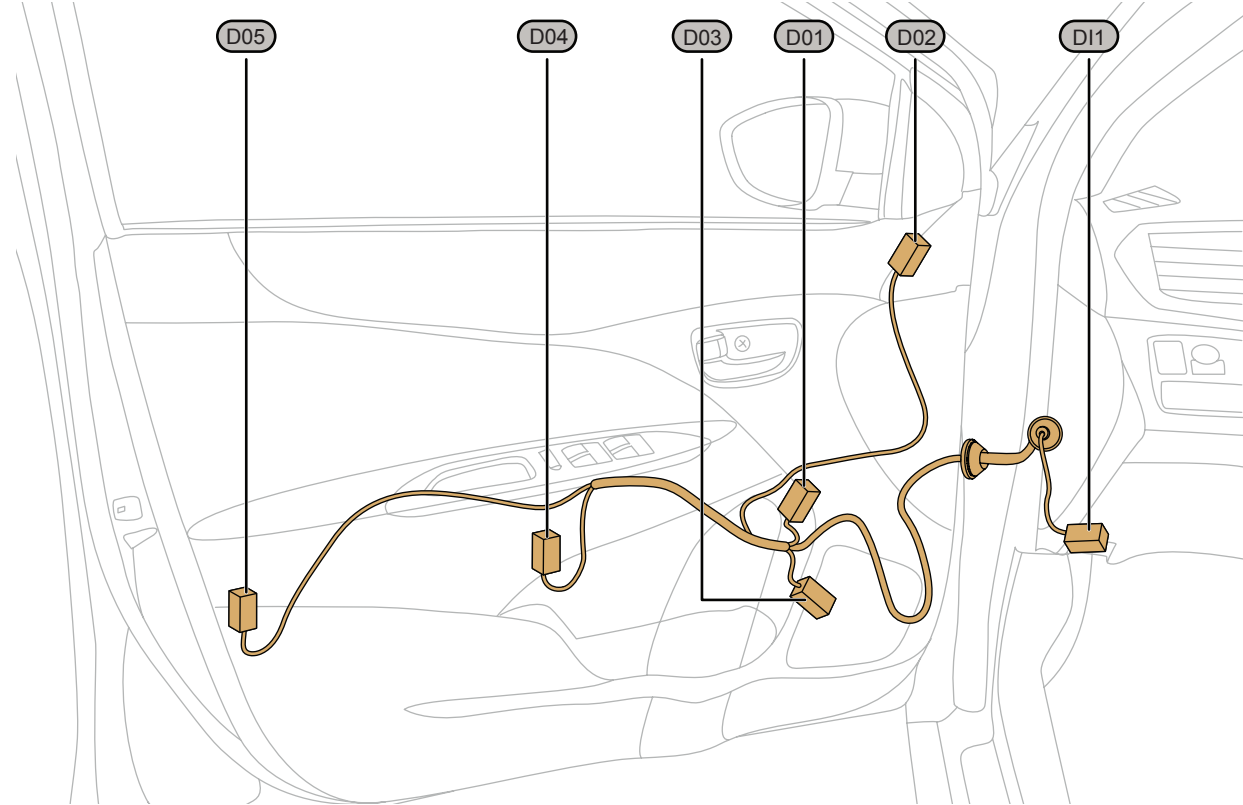

LR Door Harness

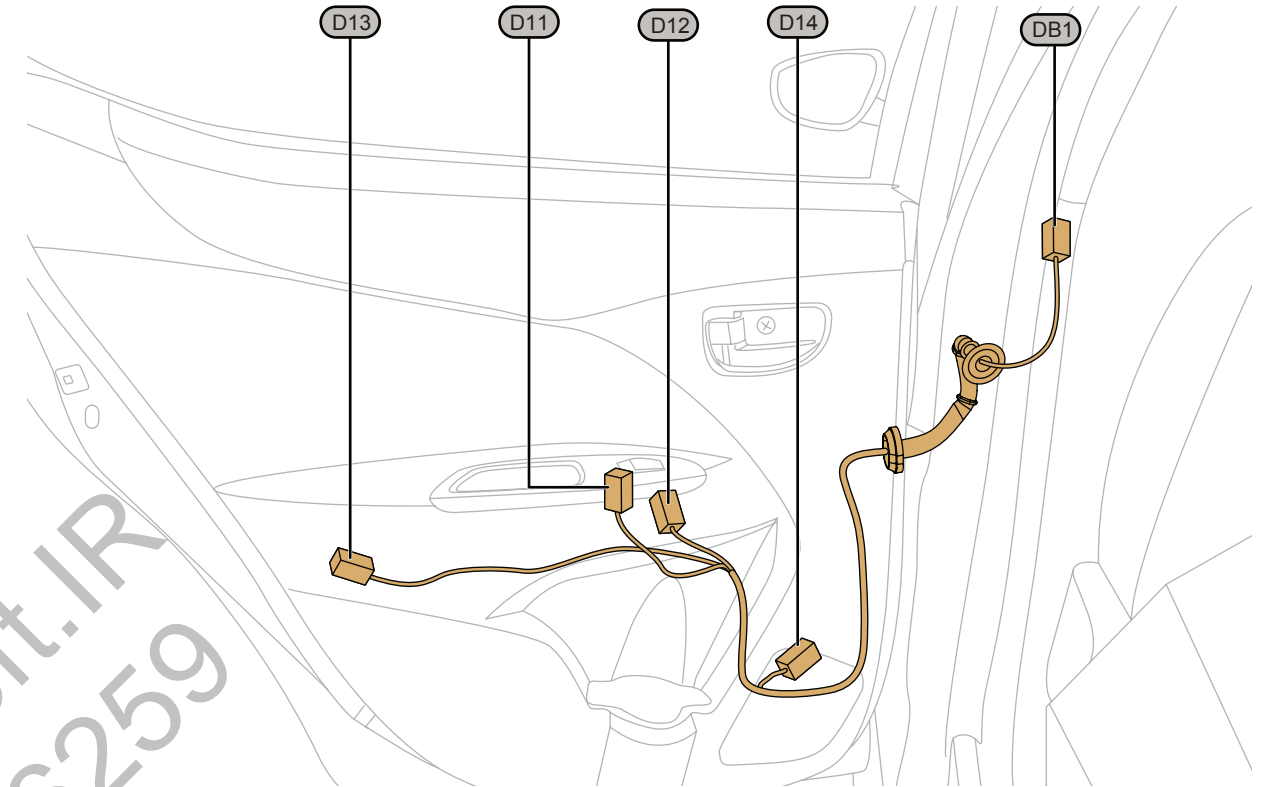

RF Door Harness

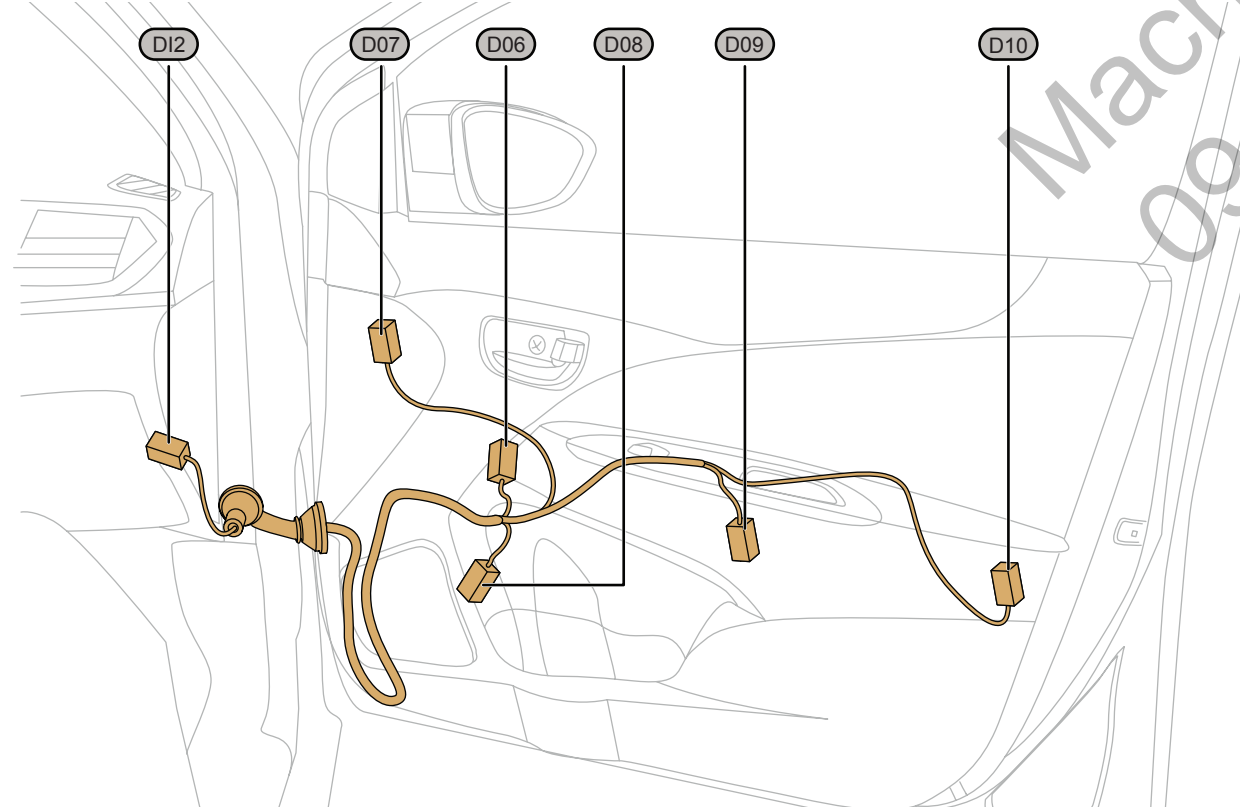

RR Door Harness

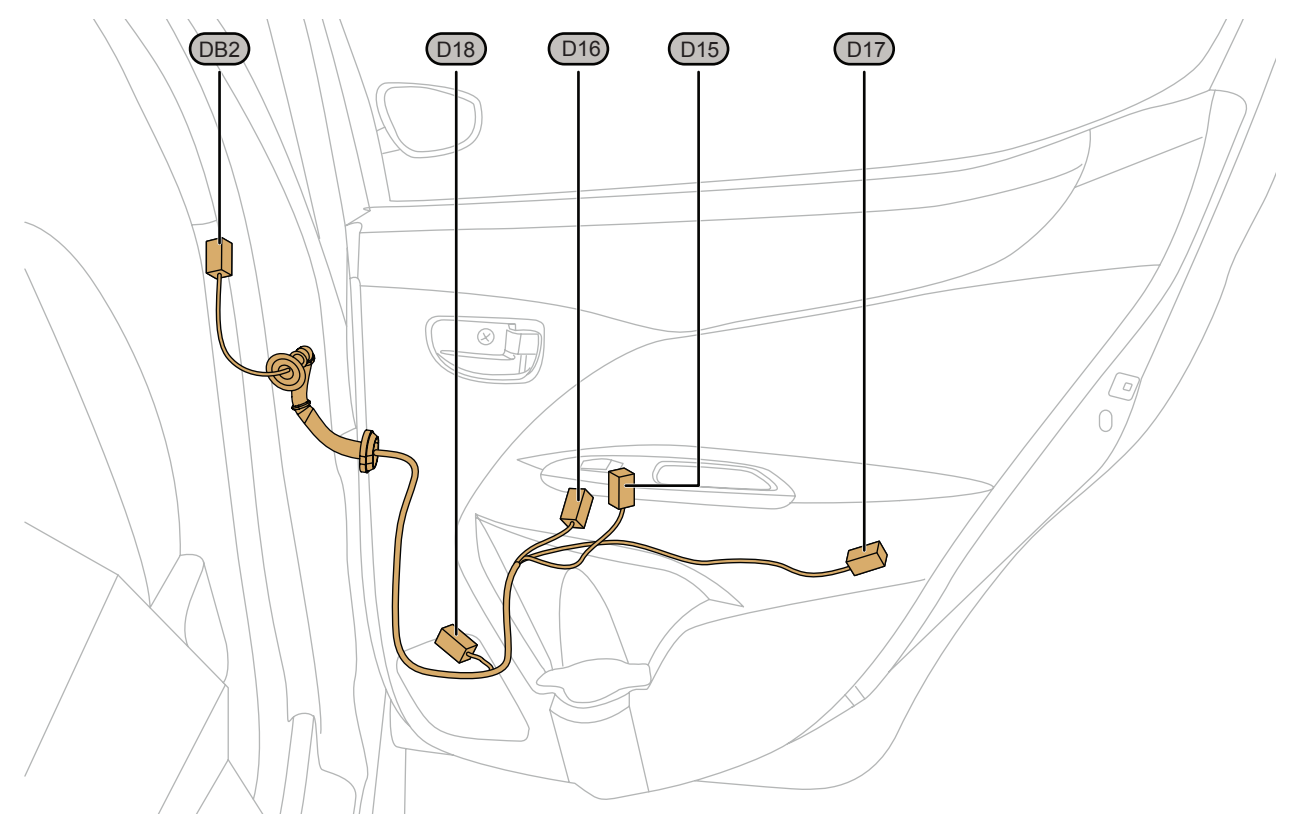

Airbag (8 Return Circuit) and Rear Bump Harness Connector Location View

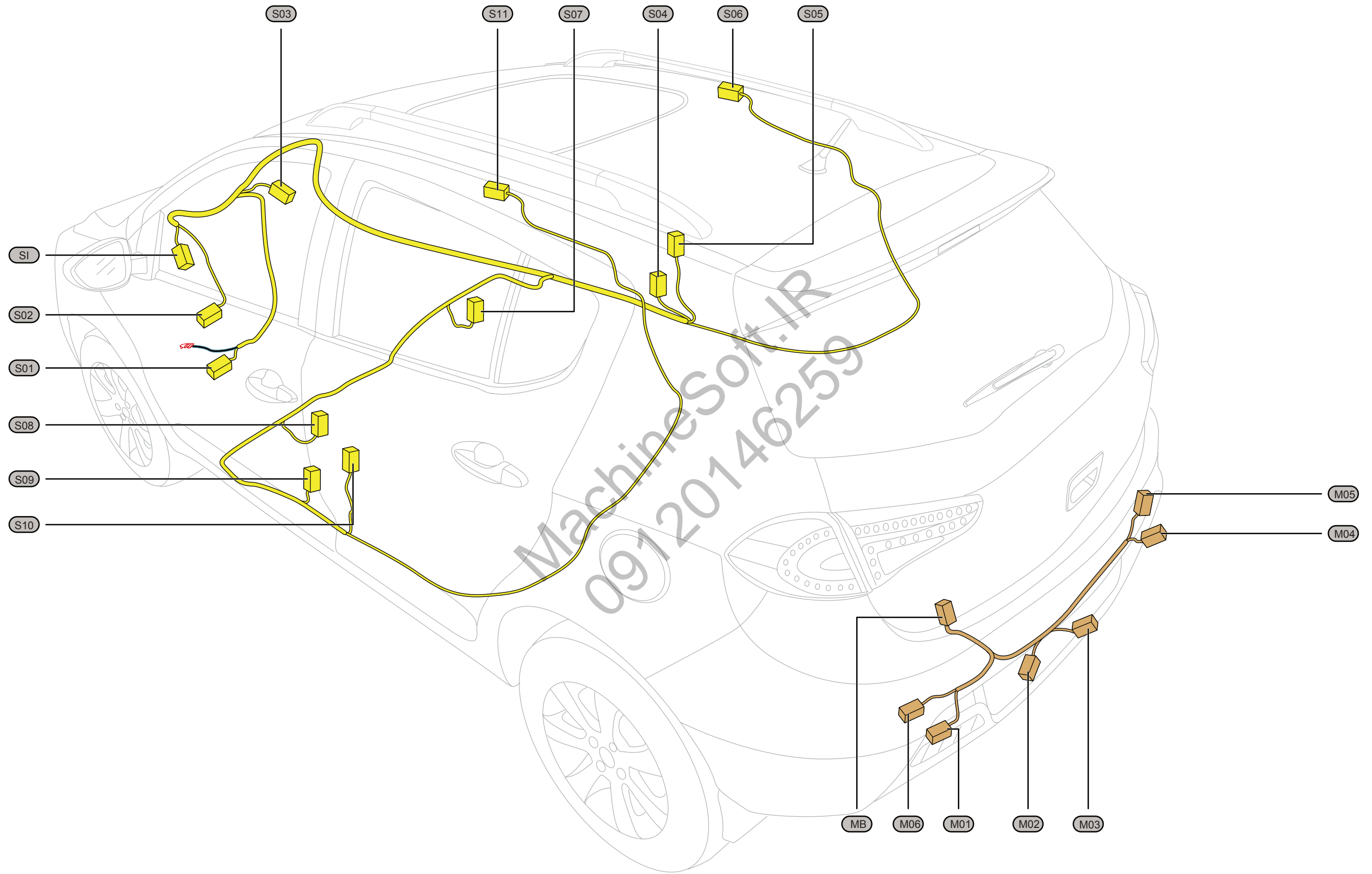

AC and Airbag(2 Return Circuit) Harness Connector Location View

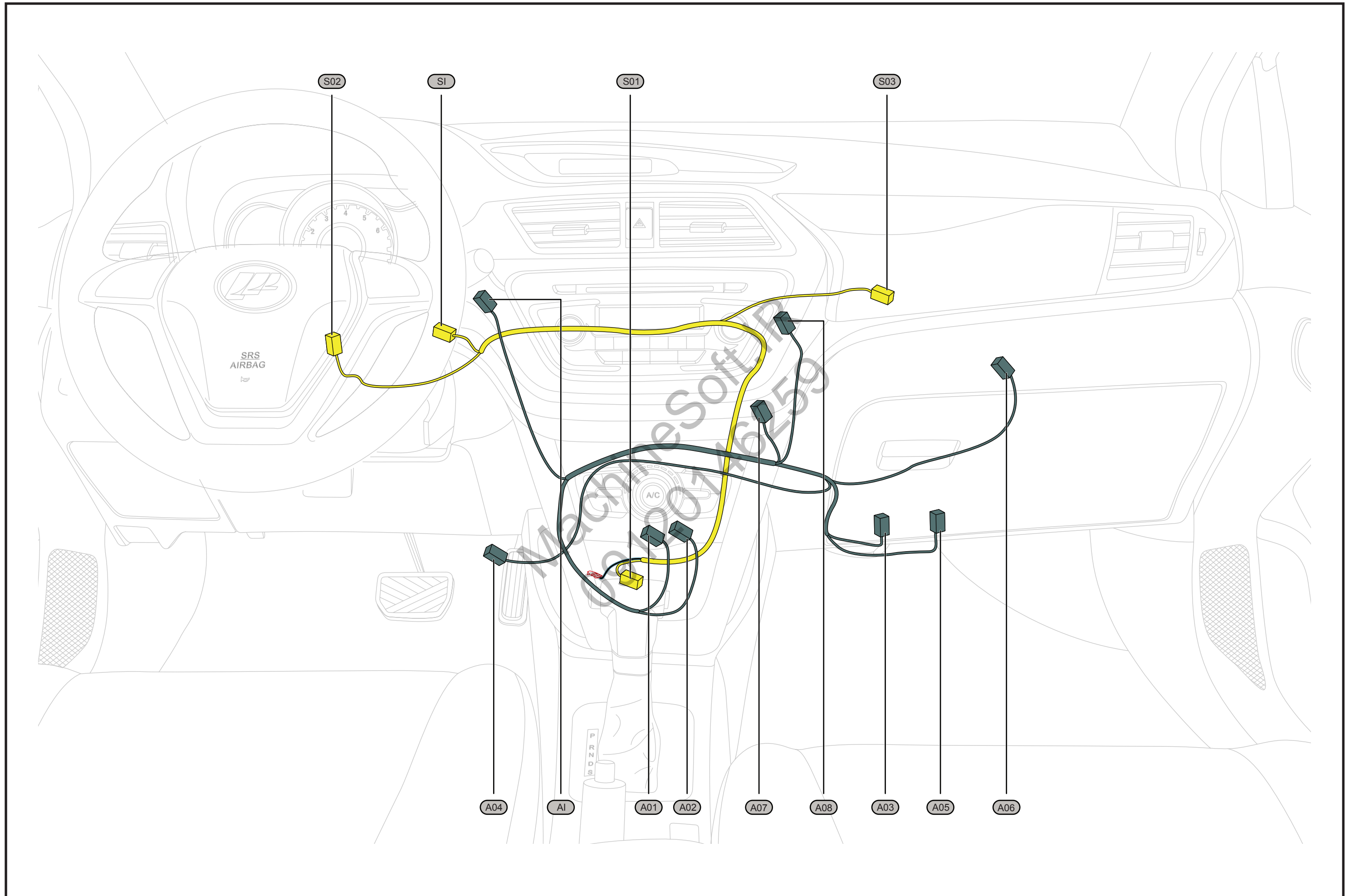

Roof Harness Connector Location View

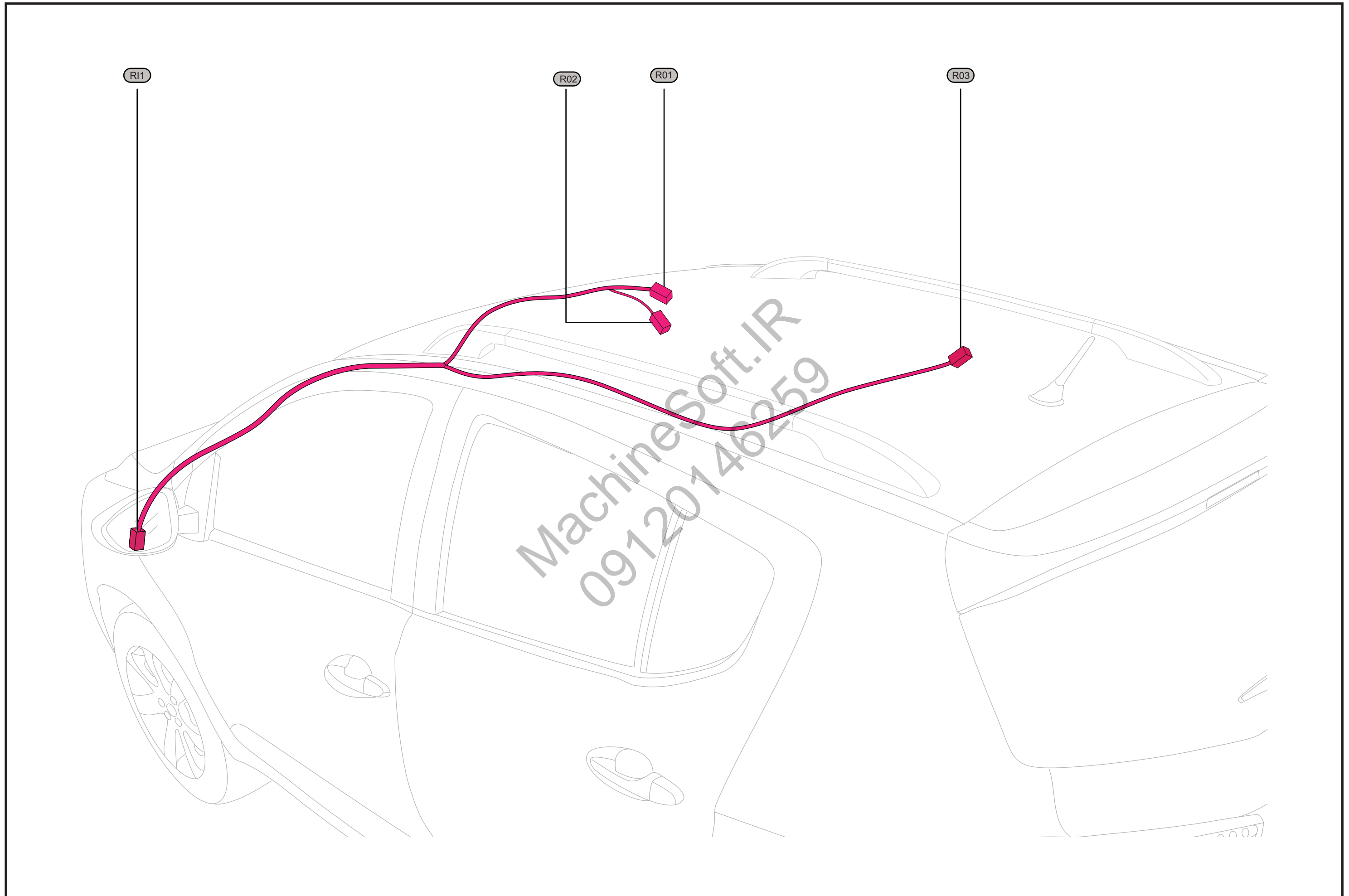

Tail Gate Harness Connector Location View

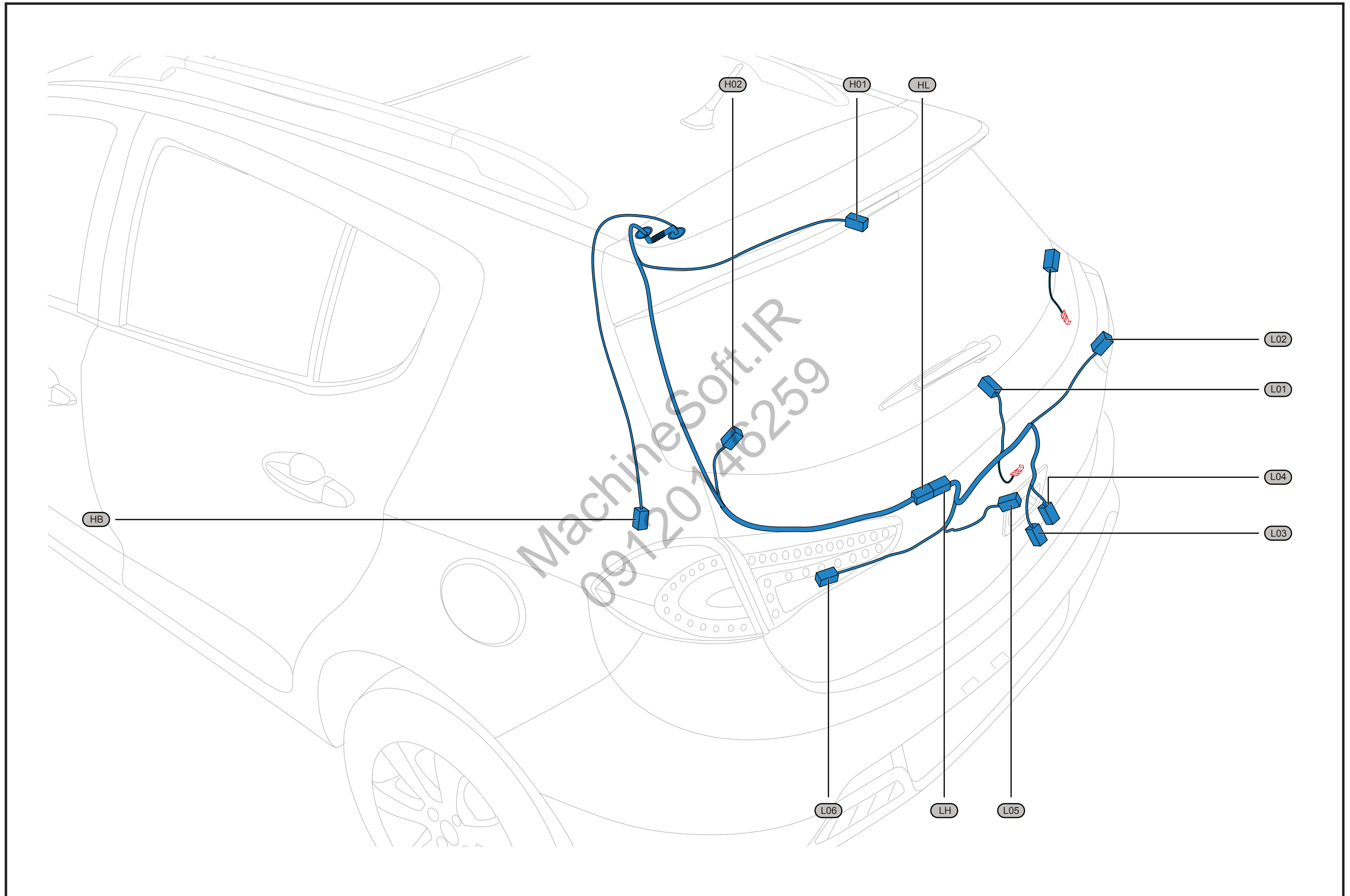

Ground Point Location View-G01-G02-G03

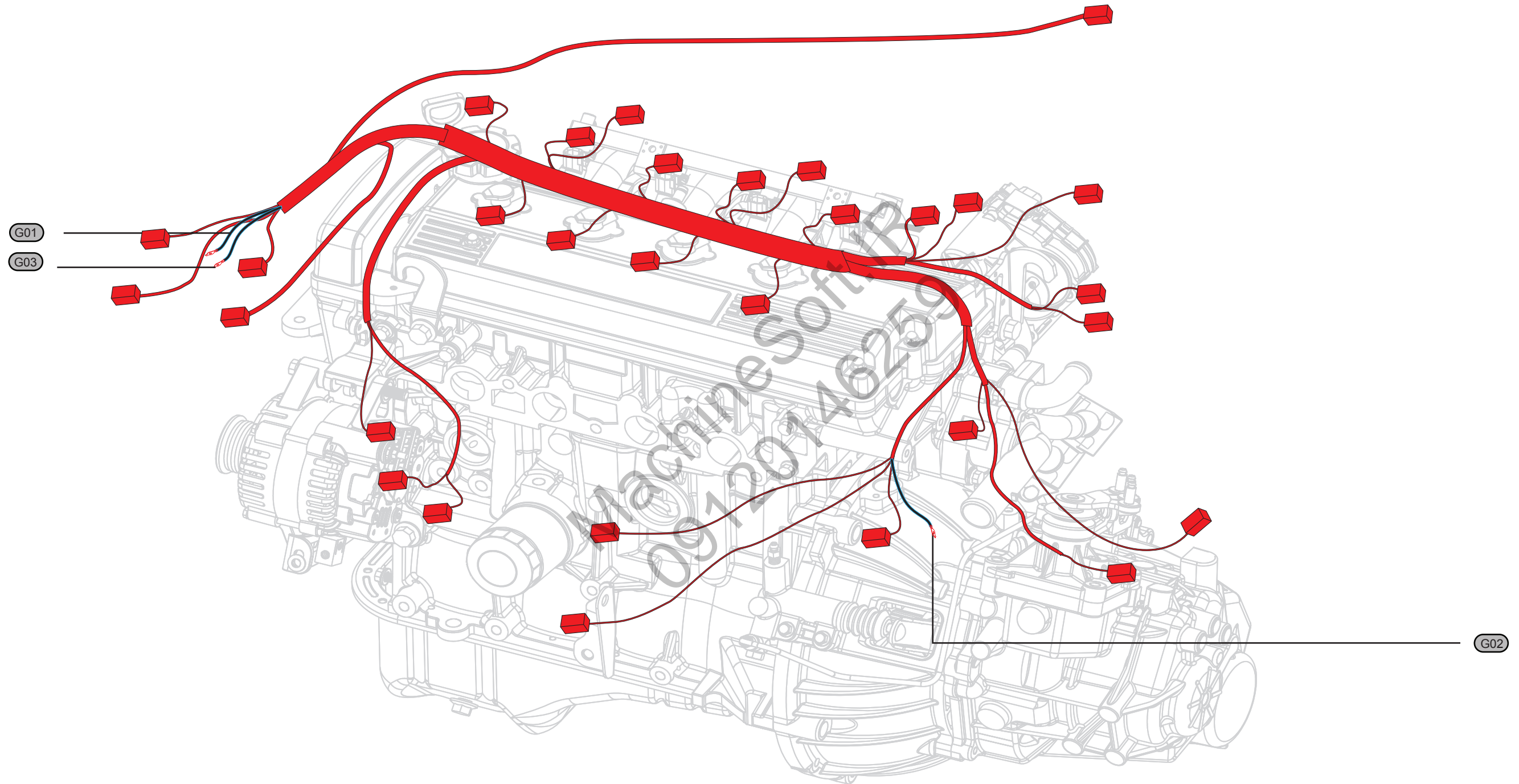

Ground Point Location View-G05

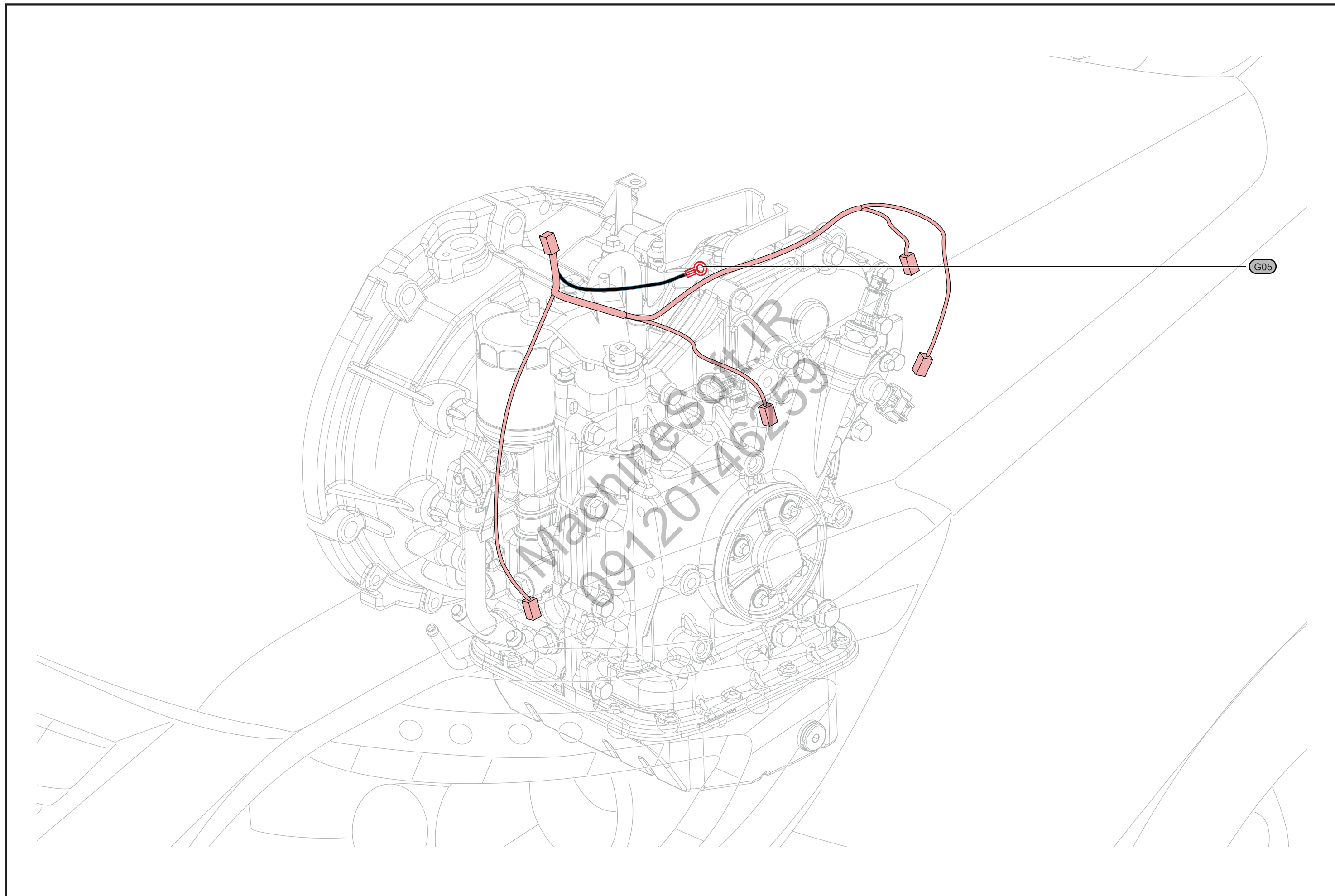

Ground Point Location View-G11-G12-G13-G14-G15

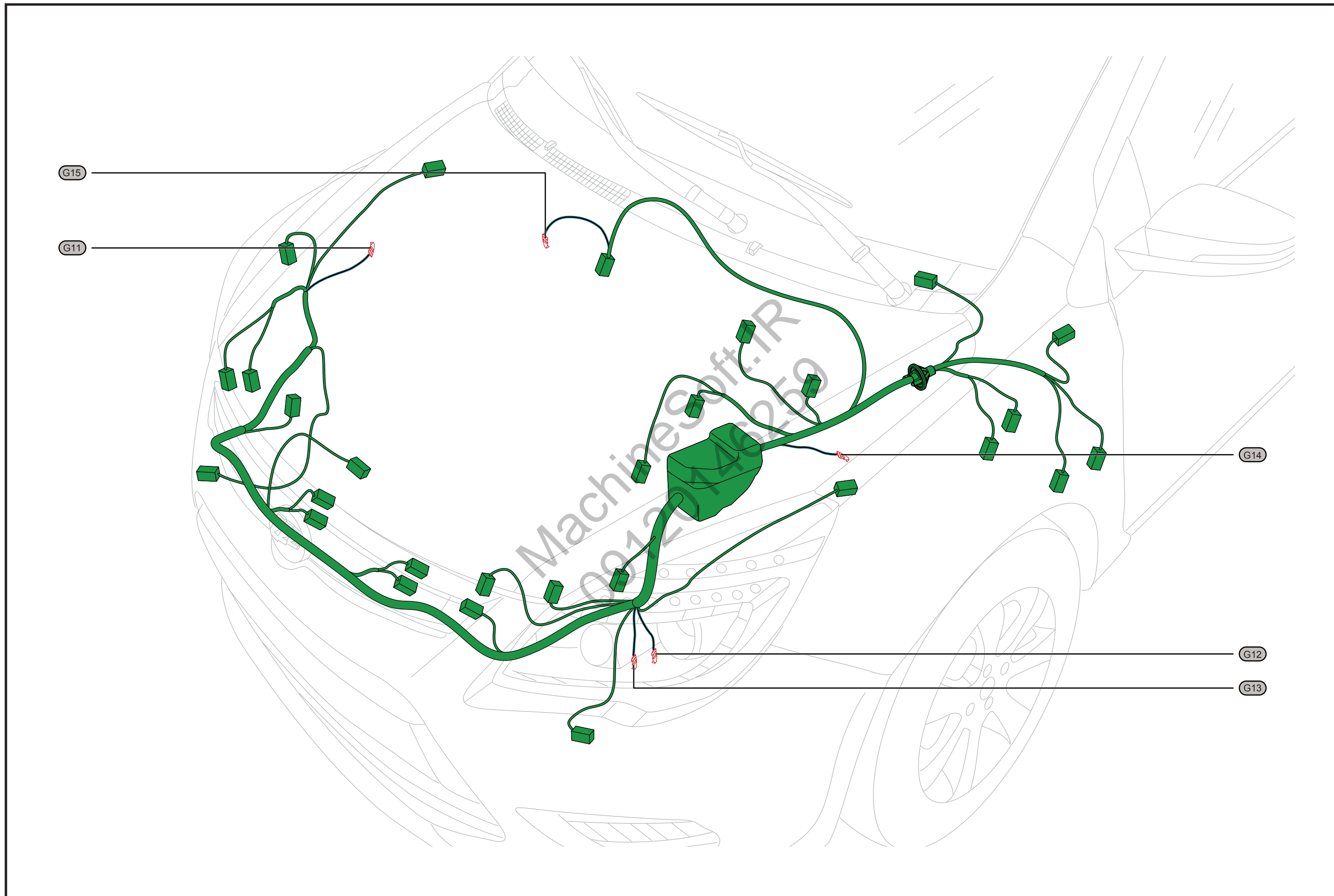

Ground Point Location View-G21-G22-G23

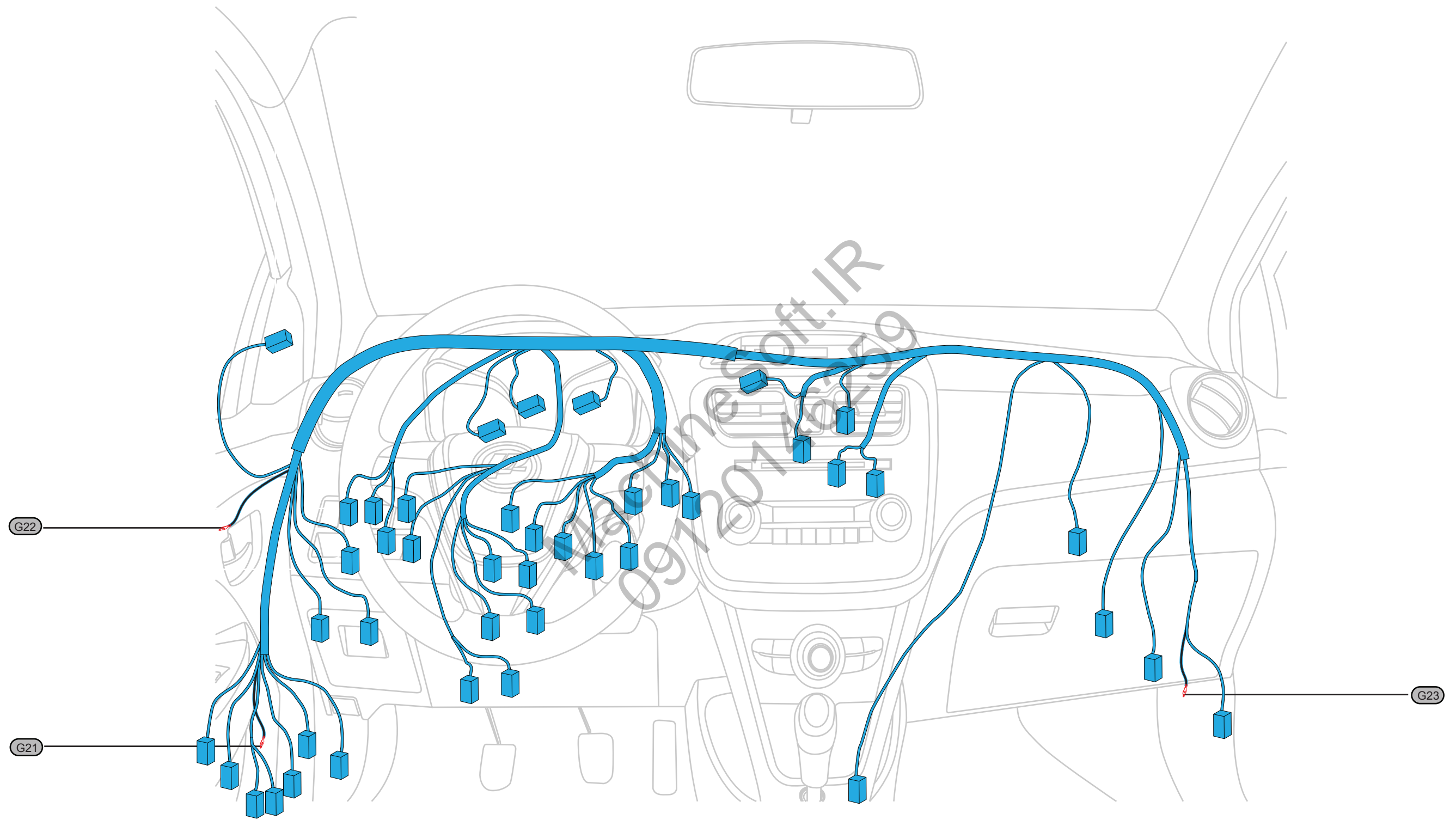

Ground Point Location View-G24-G25-G28

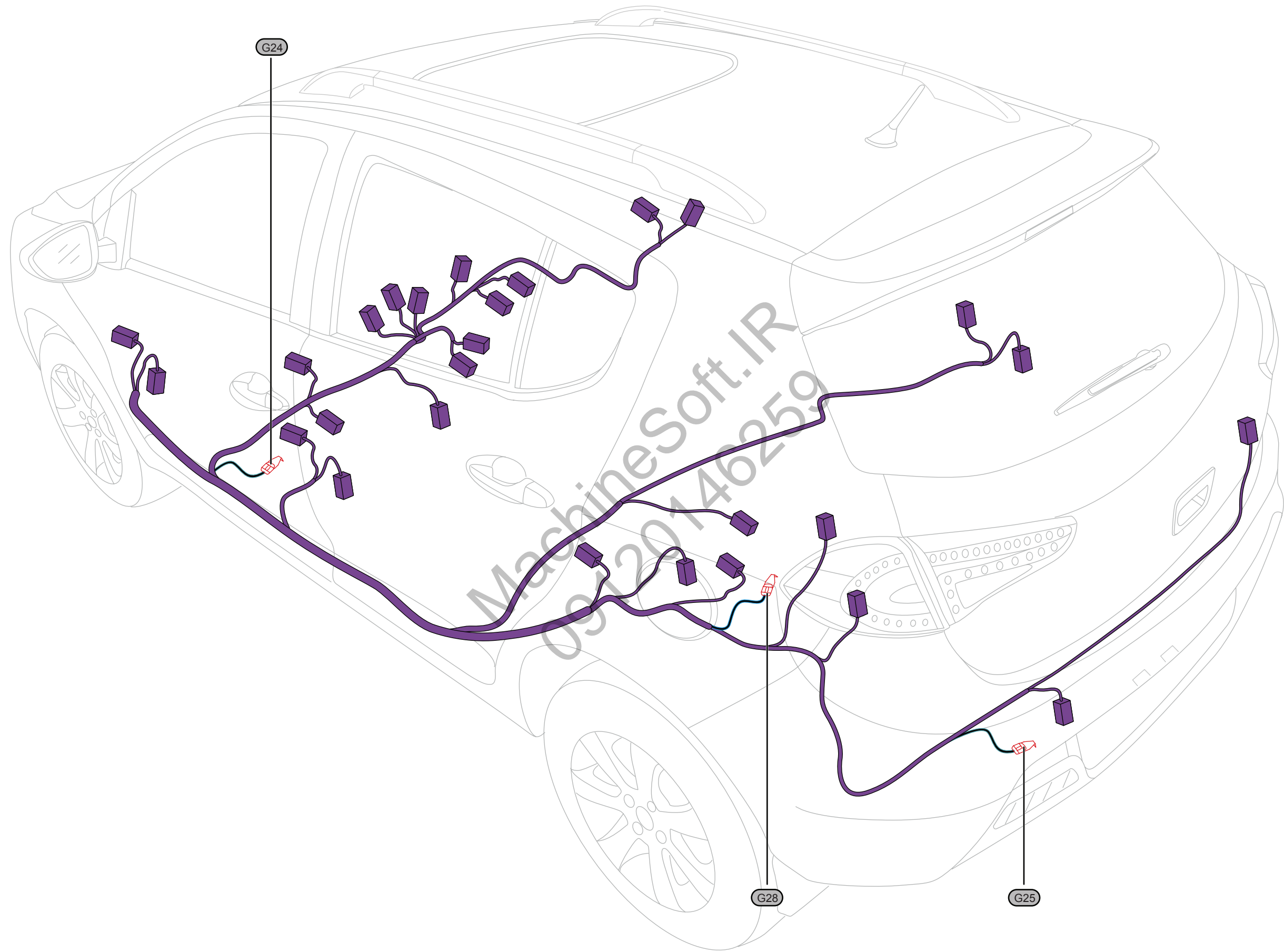

Ground Point Location View-G26

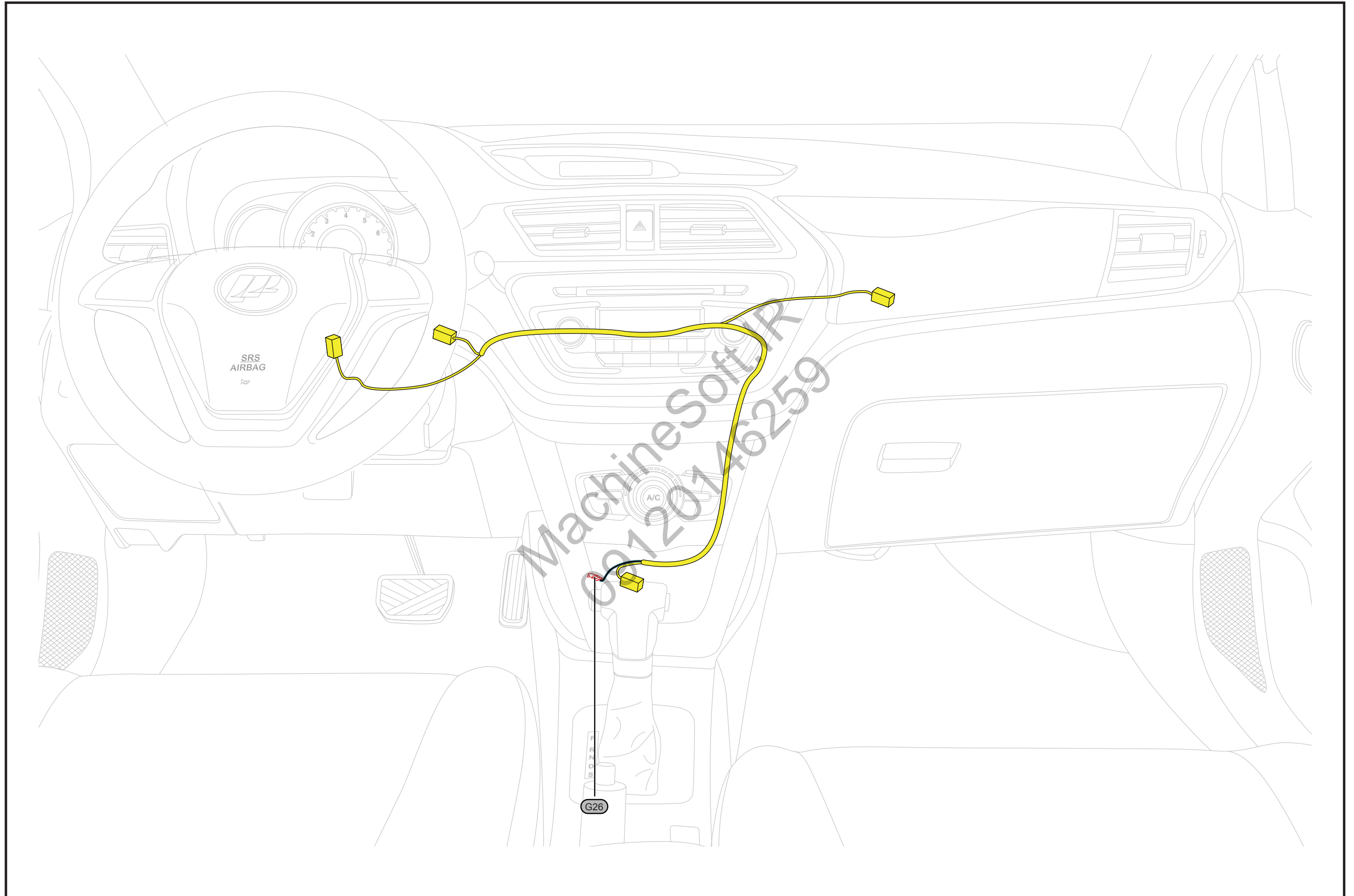

Ground Point Location View-G27-G31

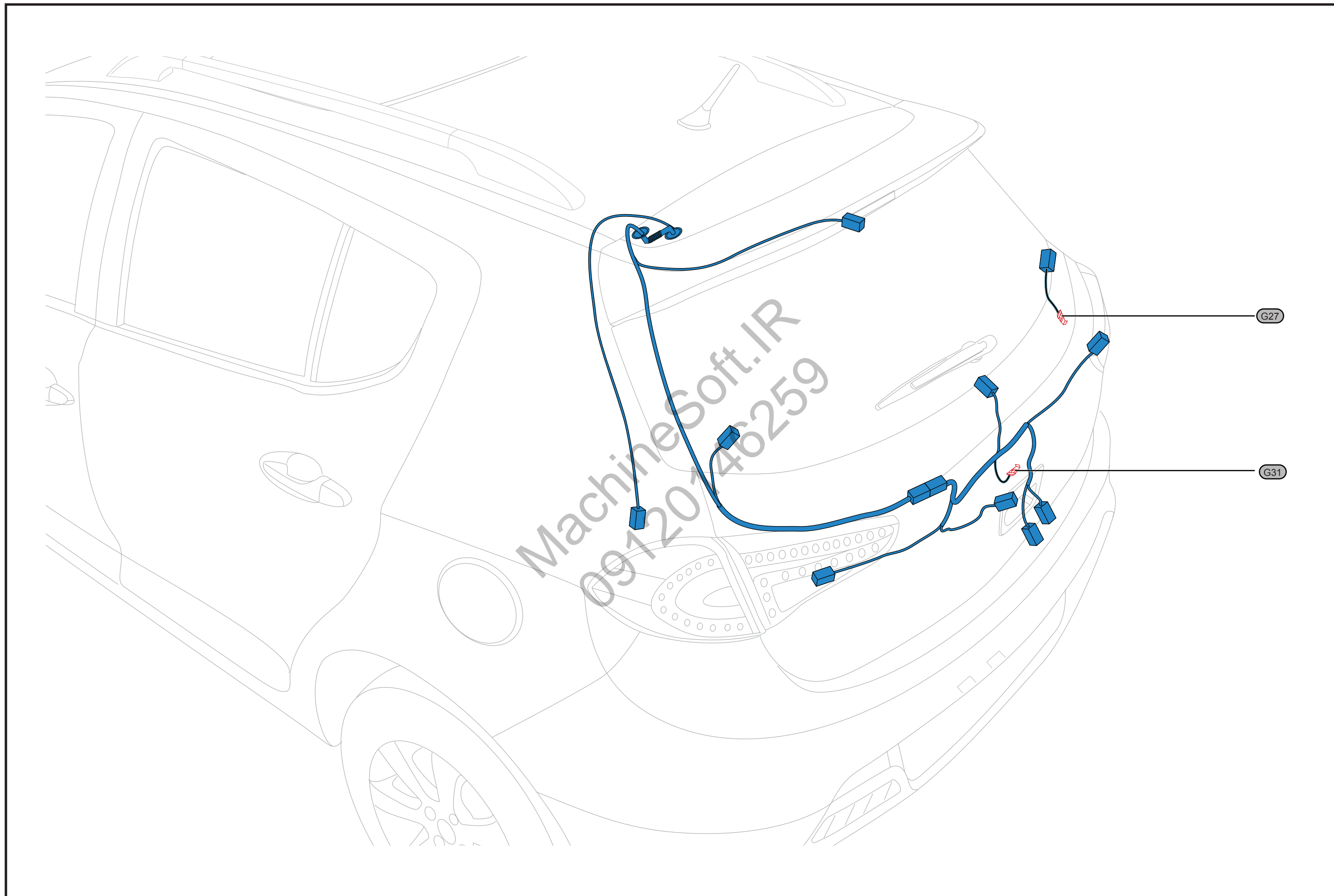

Harness Connector View

Engine Harness Connector (E--)

ECU Connector

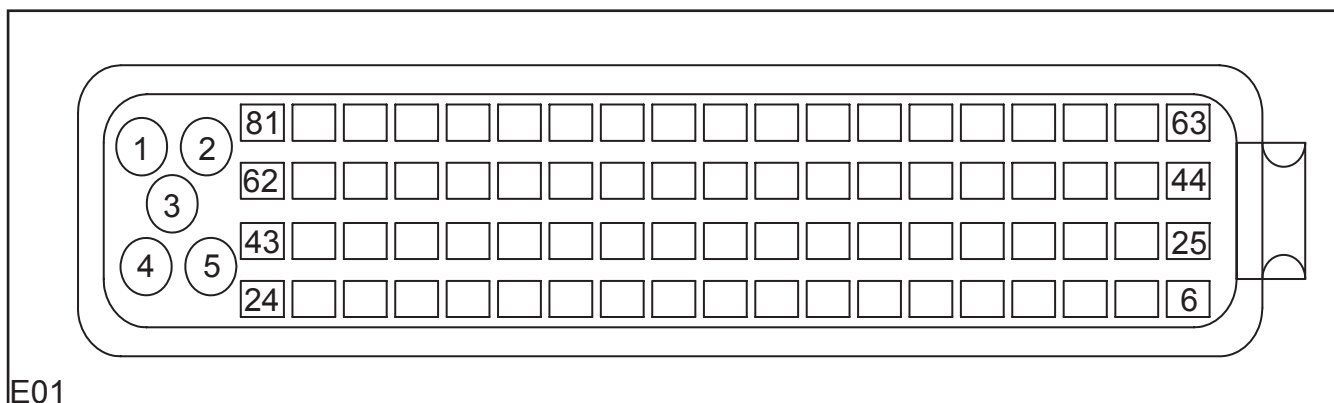

E01

E01 Pin Definition

Pin Number	Wire Width / Color	Function
1	2.00 V	NO.2 cylinder ignition coil control
2	2.00 G	NO.3 cylinder ignition coil control
3	3.00 B	Ground
4	2.00 Br	NO.4 cylinder ignition coil control
5	2.00 R/B	NO.1 cylinder ignition coil control
6	0.85 R/W	NO.2 cylinder injector control
7	0.85 Br/W	NO.3 cylinder injector control
8	0.50 W/B	Engine speed output signal
9	0.50 G/B	Engine coolant temperature indicator signal
10	0.50 P	Instantaneous fuel consumption output
11	0.50 W/Y	SVS fault indicator
12	0.85 R	Battery power
13	1.25 B/W	IG1 power
13	1.25 BI/W	IG1 power(PEPS)
14	0.85 Y	Main relay control
15	0.50 P/BI	CKP signal +
16	0.50 R/Y	APP control
17	0.50 B/BI	GND
18	0.85 O/Y	Front oxygen sensor signal
19	0.50 G/B	Knock sensor signal +
20	0.50 G	Knock sensor signal -
21	0.50 G/Gr	Brake lamp switch status signal
22	0.50 V/R	A/C pressure switch control
23		NC
24		NC
25		NC
26	0.85 G/Y	Front oxygen sensor heating signal
27	0.85 BI/V	NO.1 cylinder injector control
28	0.85 G/R	Rear oxygen sensor heating signal
29	0.50 G/Gr	Brake switch status signal
30	0.50 R/B	Up shift indicator

Engine Harness Connector (E--)

32	0.50 R/B	Power
33	0.50 O/BI	Power
34	0.50 G/W	CKP signal -
35	0.50 Br/R	GND
36	0.50 Br/B	GND
37	0.50 P/Br	IAT signal
38	0.50 Y/G	ETC signal
39	0.50 Y/B	Coolant temperature sensor signal
40	0.50 Br/V	APP signal
41		NC
42	0.50 BI	IAT signal
43		NC
44	0.85 BI/R	Main relay power
45	0.85 BI/R	Main relay power
46	0.85 Gr/BI	Canister solenoid GND
47	0.85 B/G	NO.4 cylinder injector control signal
48	0.85 Gr/Y	GND
49	0.50 R/Y	Down shift indicator
50	0.50 W/B	Low speed fan control
51	0.85 B	Ground
52		NC
53	0.85 B	Ground
54	0.50 W/P	signal
55	0.85 Gr	Rear oxygen sensor signal
56		NC
57	0.50 BI/Y	Headlamp open signal
58	0.50 G/W	Brake switch status signal
59	0.50 V/W	Vehicle speed signal input
60	0.50 G/V	A/C pressor switch signal
61	0.85 B	Ground
62	0.50 G/Y	CAN-L
62	0.50 W/R	CAN-H(PEPS)
63	0.85 BI/R	Main relay power
64	0.50 P/B	Power +
65	0.50 P/B	Power +
66	0.50 Y	Power -
67	0.50 Y	Power -
68	0.85 W/R	High speed fan control
69	0.85 W/BI	Fuel pump relay control
70	0.50 W/Y	A/C compressor control
71	0.50 P/G	K-line
72		NC
73		NC
74	0.50 B/W	Clutch switch signal
75		NC
76		NC

Harness Connector View

Engine Harness Connector (E--)

Pin Number	Wire Width / Color	Function
77	0.50 BI/G	Power steering switch singal
78	0.50 V	GND
79	0.50 G/W	CMP signal
80	0.85 B	Ground
81	0.50 G/B	CAN-H
81	0.50 W/B	CAN-L(PEPS)

Power Steering Switch Connector

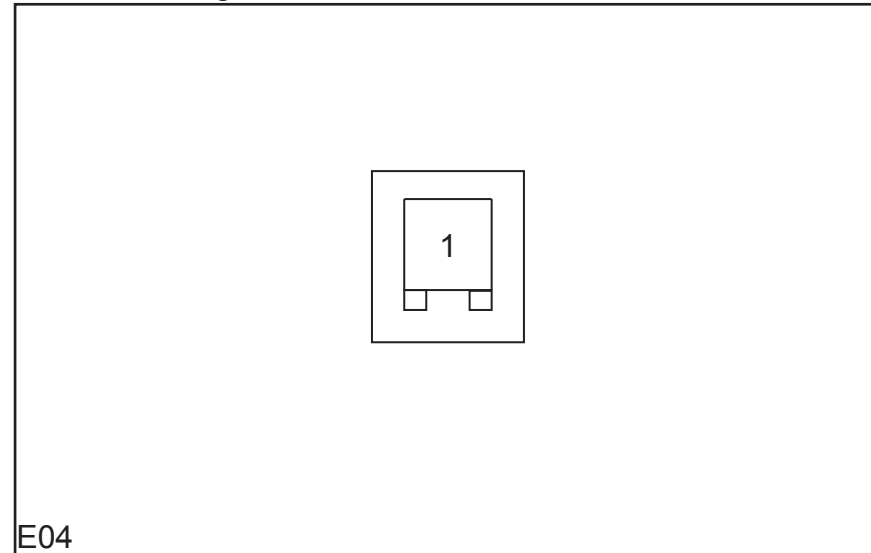

E04 Pin Definition

Pin Number	Wire Width / Color	Function
1	0.50 BI/G	Power steering switch signal

Camshaft Position Sensor Connector

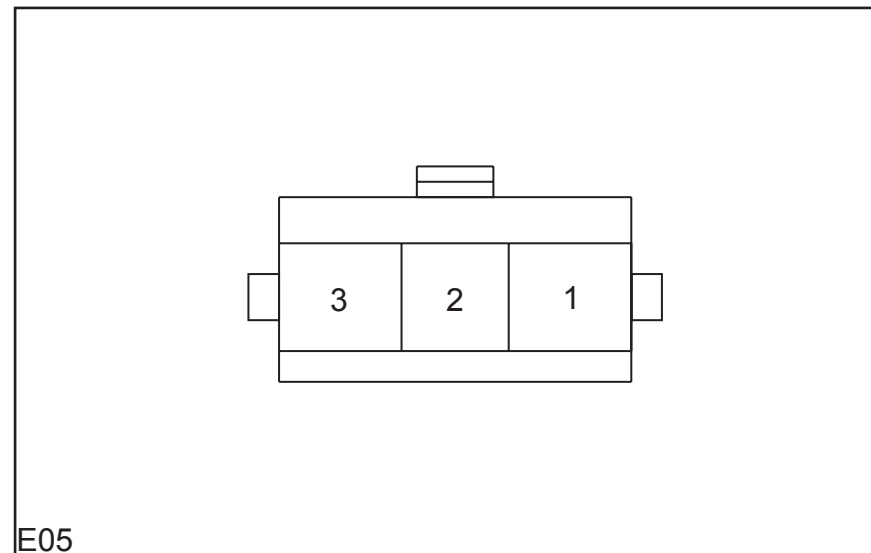

E05 Pin Definition

Pin Number	Wire Width / Color	Function
1	0.50 R/B	Power
2	0.50 G/W	CMP signal
3	0.50 Br/B	GND

Engine Harness Connector (E--)

NO 1 Cylinder Injector Connector

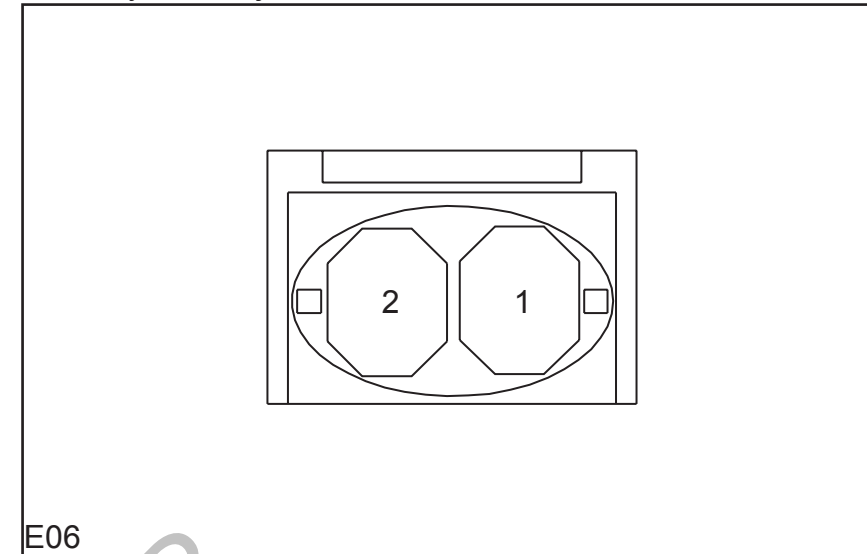

E06 Pin Definition

Pin Number	Wire Width / Color	Function
1	0.85 BI/V	NO.1 cylinder injector control
2	0.85 BI/R	Main relay power

NO 2 Cylinder Injector Connector

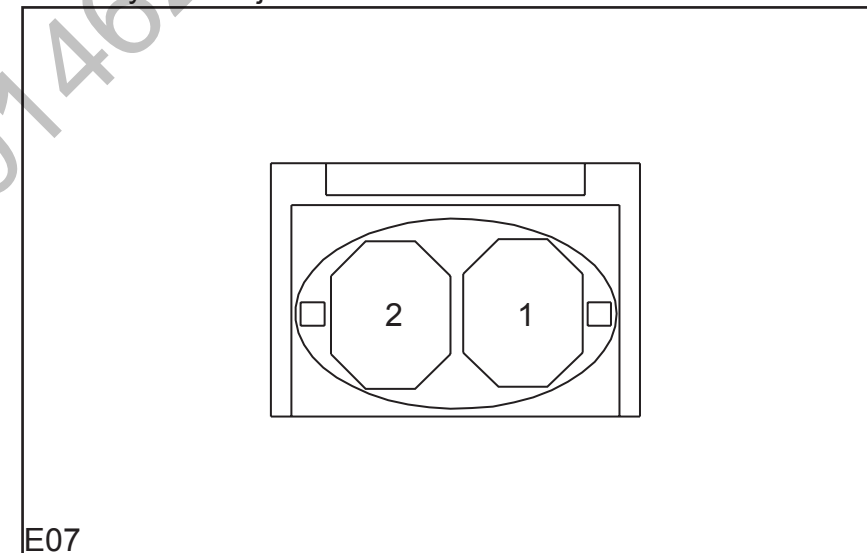

E07 Pin Definition

Pin Number	Wire Width / Color	Function
1	0.85 R/W	NO.2 cylinder injector control
2	0.85 BI/R	Main relay power

Harness Connector View

Engine Harness Connector (E--)

NO 3 Cylinder Injector Connector

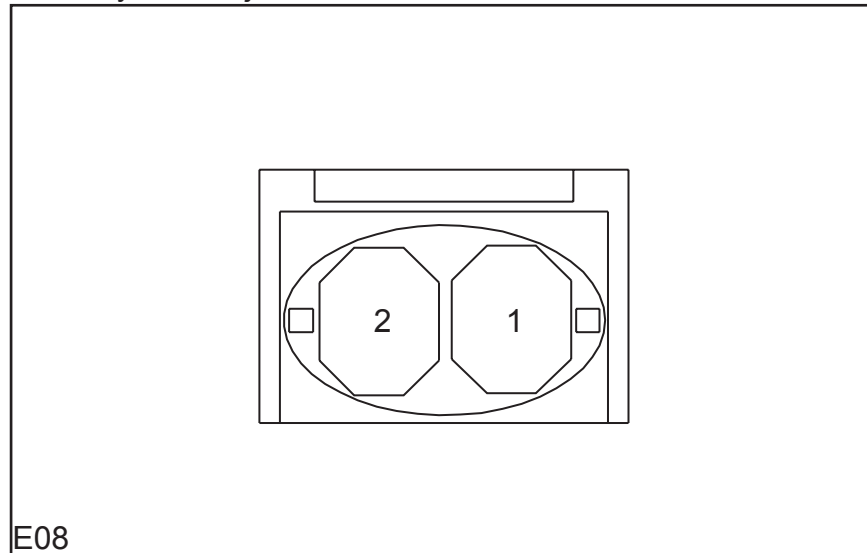

E08

E08 Pin Definition

Pin Number	Wire Width / Color	Function
1	0.85 Br/W	NO.3 cylinder injector control
2	0.85 Bl/R	Main relay power

NO 4 Cylinder Injector Connector

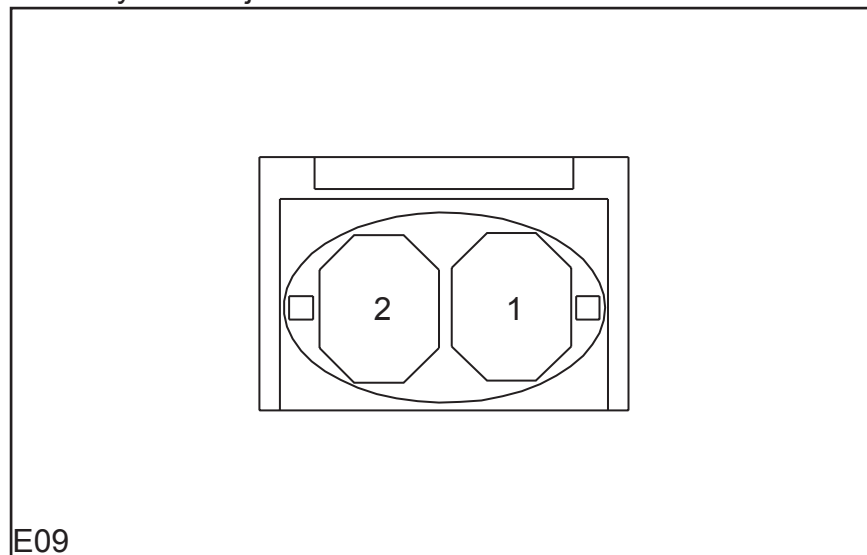

E09

E09 Pin Definition

Pin Number	Wire Width / Color	Function
1	0.85 B/G	NO.4 cylinder injector control
2	0.85 Bl/R	Main relay power

Engine Harness Connector (E--)

Intake Temperature/Pressure Sensor Connector

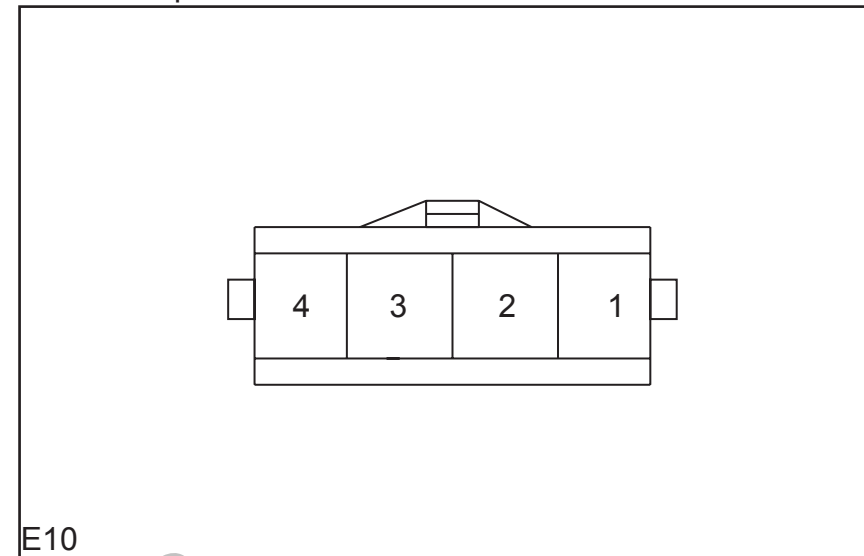

E10

E10 Pin Definition

Pin Number	Wire Width / Color	Function
1	0.50 P/Br	MAP signal
2	0.50 O/Bl	Power
3	0.50 Bl	IAT signal
4	0.50 B/Bl	GND

Canister solenoid Valve Connector

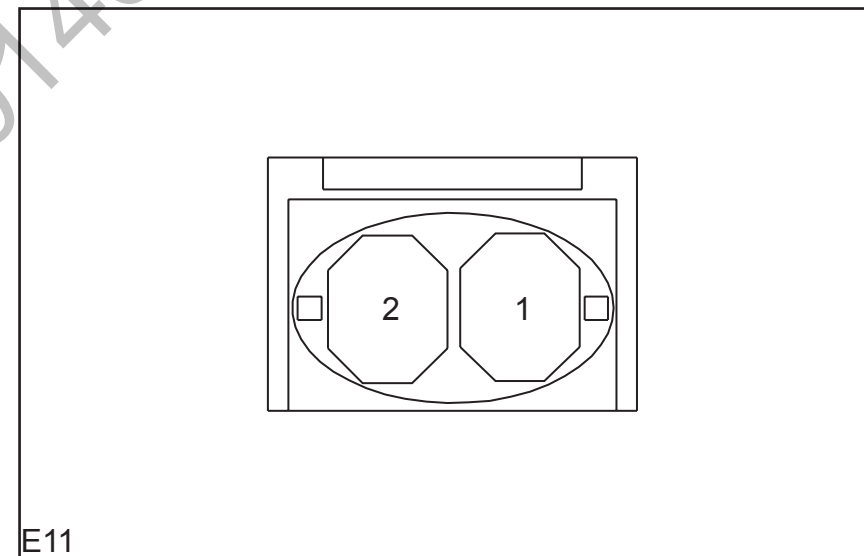

E11

E11 Pin Definition

Pin Number	Wire Width / Color	Function
1	0.85 Gr/Bl	Signal
2	0.85 Bl/R	Main relay power

Harness Connector View

Engine Harness Connector (E--)
Intake VVT Valve Connector

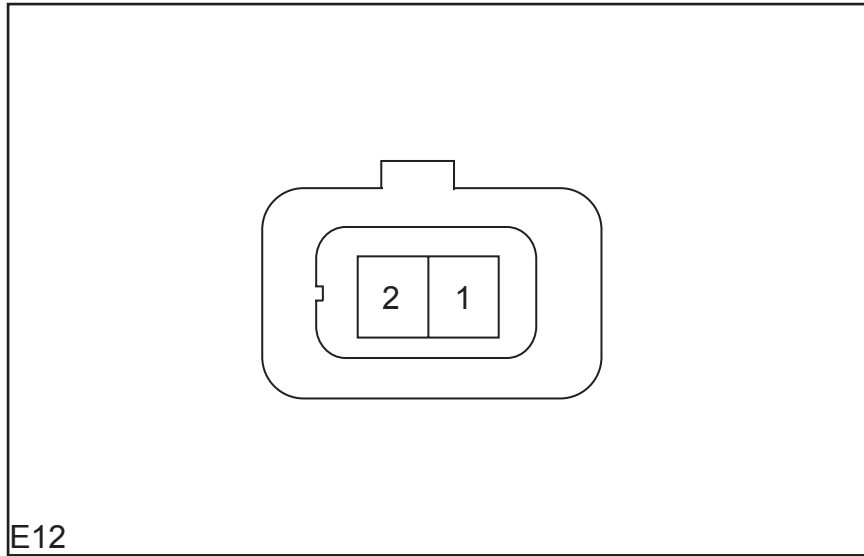

E12

E12 Pin Definition

Pin Number	Wire Width / Color	Function
1	0.85 Gr/Y	Signal
2	0.85 Bl/R	Main relay power

Knock Sensor Connector

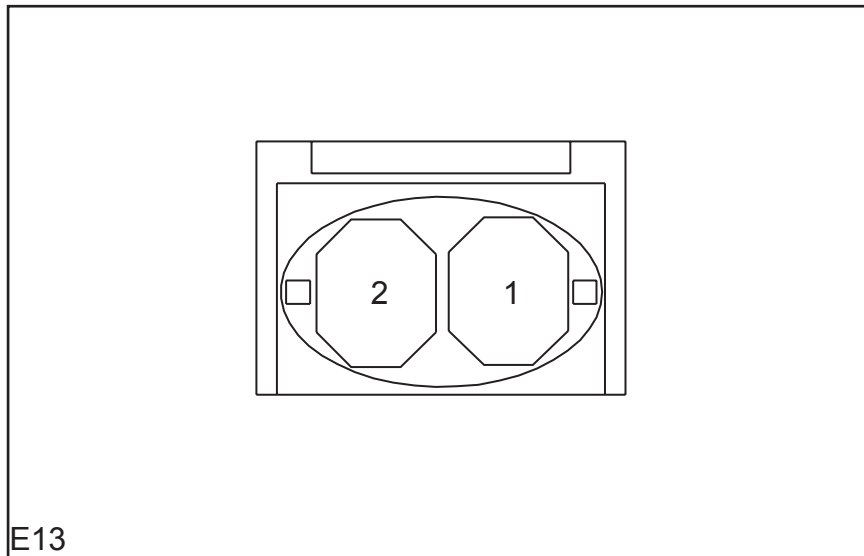

E13

E13 Pin Definition

Pin Number	Wire Width / Color	Function
1	0.50 G/B	Knock sensor signal +
2	0.50 G	Knock sensor signal -

Engine Harness Connector (E--)
Starter Connector

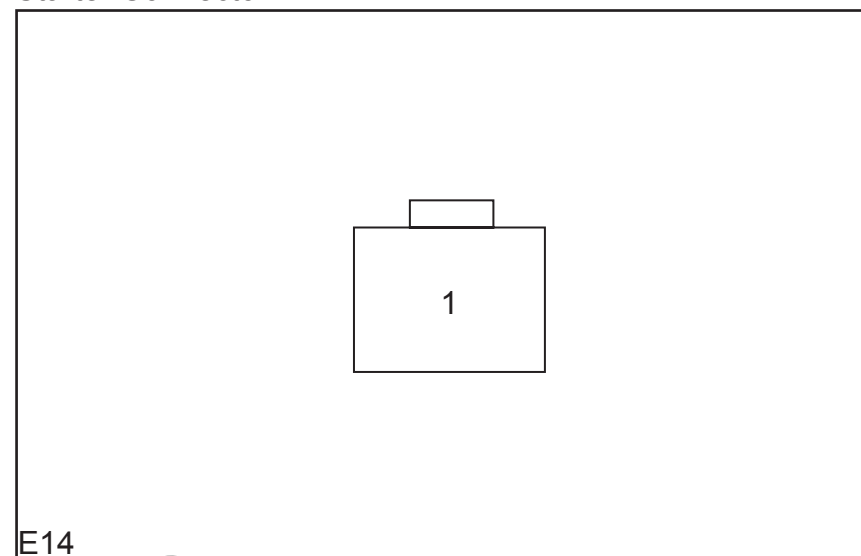

E14

E14 Pin Definition

Pin Number	Wire Width / Color	Function
1	2.00 B/Y	Start power

Electronic Throttle Valve Connector

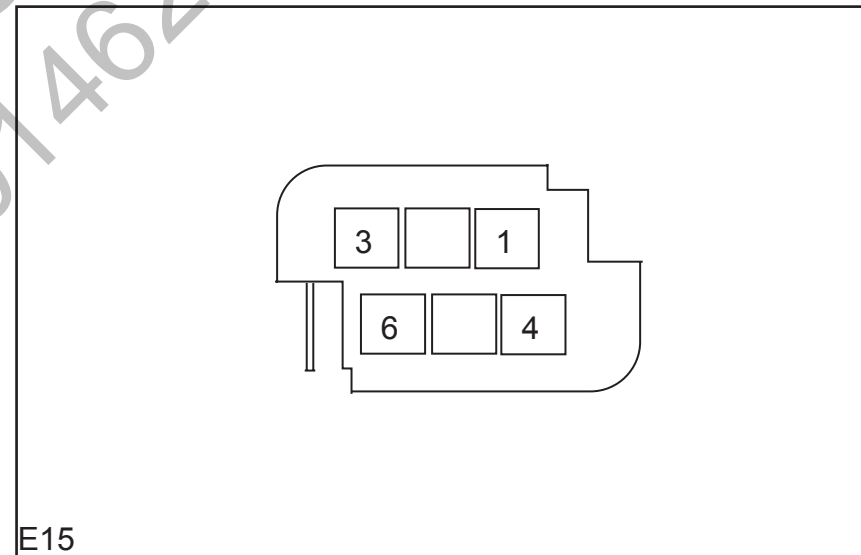

E15

E15 Pin Definition

Pin Number	Wire Width / Color	Function
1	0.50 P/B	Power +
2	0.50 Y/G	TPS signal
3	0.50 W/P	TPS signal
4	0.50 Y	Power -
5	0.50 V	GND
6	0.50 R/B	Power

Harness Connector View

Engine Harness Connector (E--)

Coolant Temperature Sensor Connector

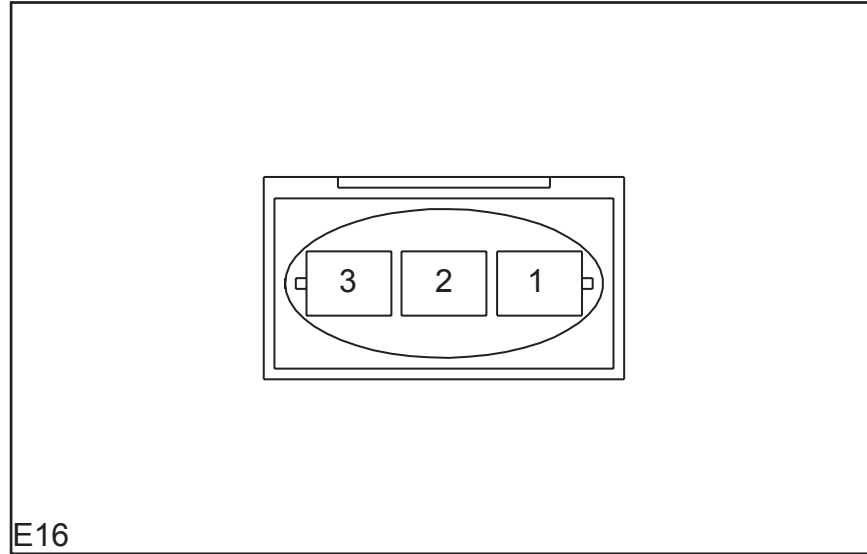

E16

E16 Pin Definition

Pin Number	Wire Width / Color	Function
1	0.50 B/BI	GND
2		NC
3	0.50 Y/B	Coolant temperature sensor signal

Engine Harness Connector (E--)

Crankshaft Position Sensor Connector

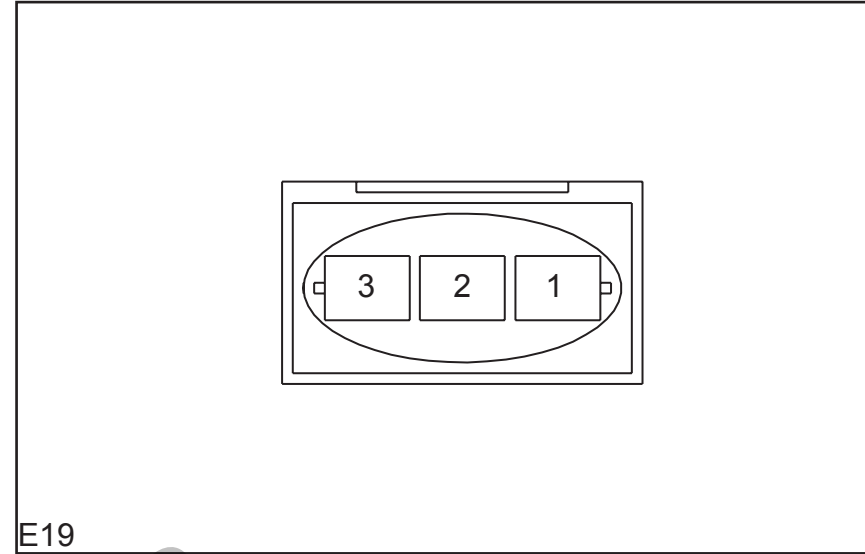

E19

E19 Pin Definition

Pin Number	Wire Width / Color	Function
1	0.50 B	Ground
2	0.50 G/W	CKP signal -
3	0.50 P/BI	CKP signal +

Reverse Lamp Switch Connector

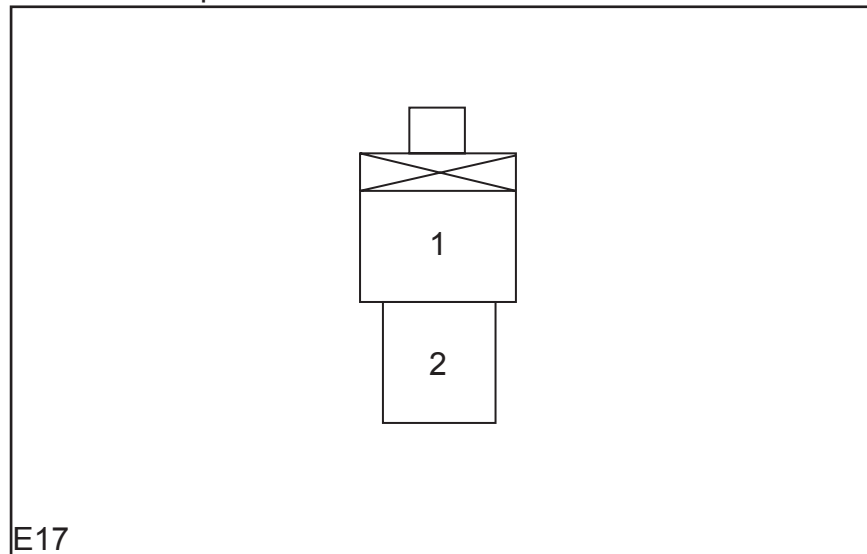

E17

E17 Pin Definition

Pin Number	Wire Width / Color	Function
1	0.50 G/BI	Reverse lmap switch power
2	0.50 G/P	Reverse lmap power

Rear Oxygen Sensor Connector

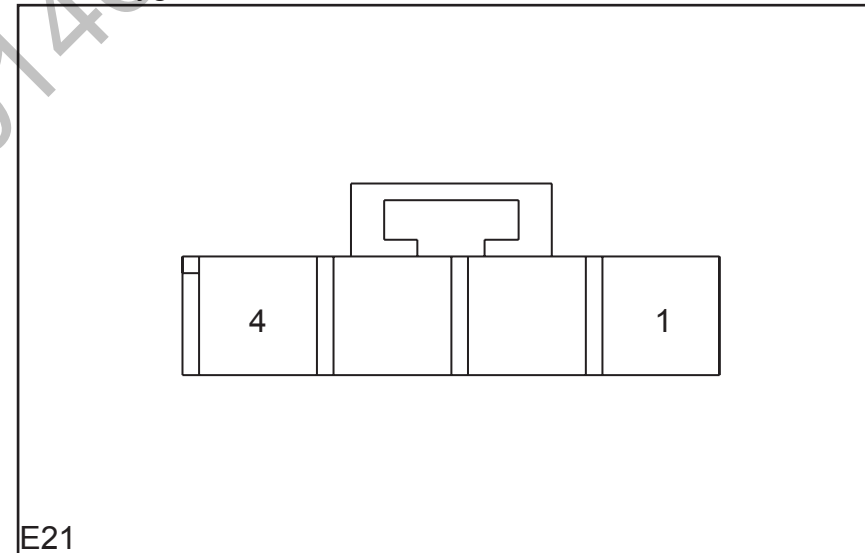

E21

E21 Pin Definition

Pin Number	Wire Width / Color	Function
1	0.85 BI/R	Rear oxygen sensor power
2	0.85 G/R	Rear oxygen sensor heating signal
3	0.85 Gr	Rear oxygen sensor signal -
4	0.85 Br/B	Ground

Harness Connector View

Engine Harness Connector (E--)

Front Oxygen Sensor Connector

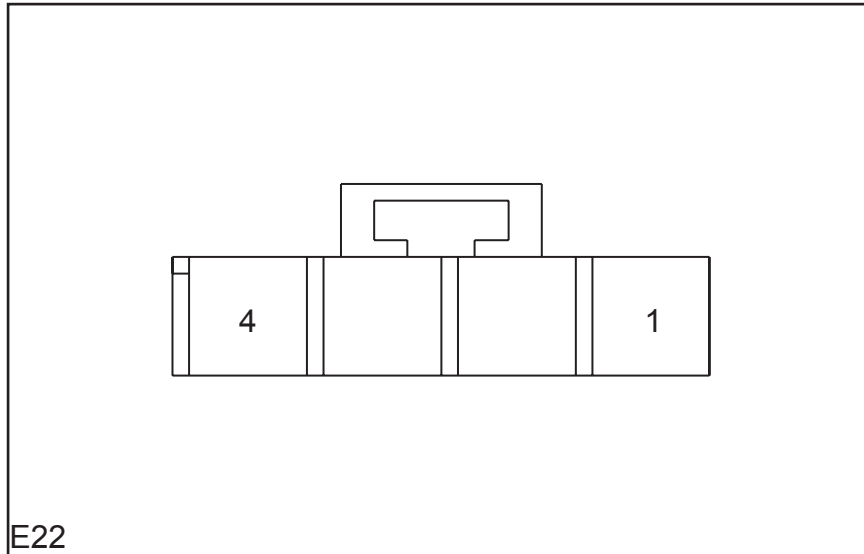

E22

E22 Pin Definition

Pin Number	Wire Width / Color	Function
1	0.85 BI/R	Front oxygen sensor power
2	0.85 G/Y	Front oxygen sensor heating signal
3	0.85 O/Y	Front oxygen sensor signal
4	0.85 Br/B	Ground

Engine Harness Connector (E--)

NO3 Cylinder Ignition Coil Connector

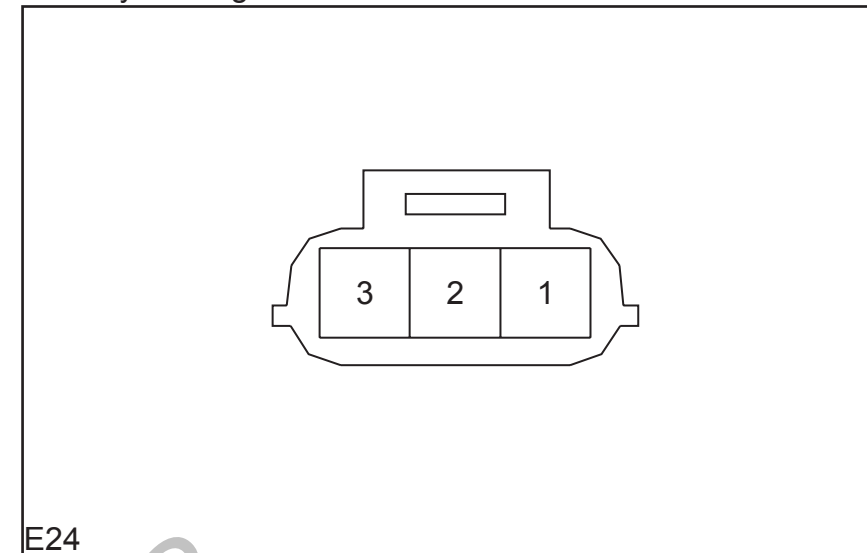

E24

E24 Pin Definition

Pin Number	Wire Width / Color	Function
1	2.00 G	Ignition coil control
2	0.85 BI/R	Main relay power
3	0.85 B	Ground

NO4 Cylinder Ignition Coil Connector

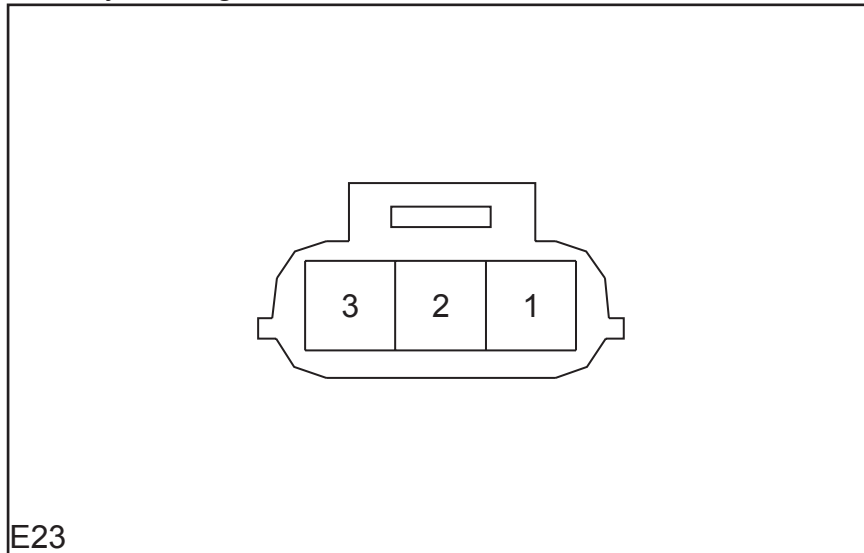

E23

E23 Pin Definition

Pin Number	Wire Width / Color	Function
1	2.00 Br	Ignition coil control
2	0.85 BI/R	Main relay power
3	0.85 B	Ground

NO2 Cylinder Ignition Coil Connector

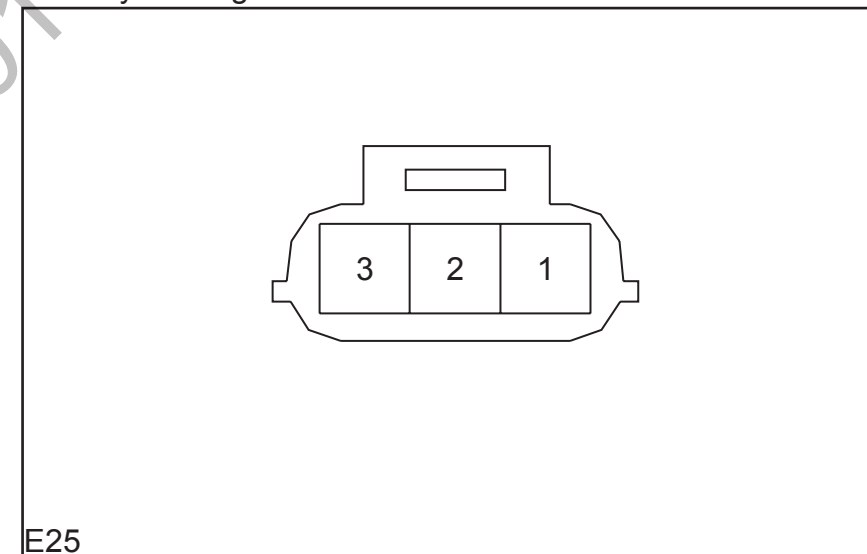

E25

E25 Pin Definition

Pin Number	Wire Width / Color	Function
1	2.00 V	Ignition coil control
2	0.85 BI/R	Main relay power
3	0.85 B	Ground

Harness Connector View

Engine Harness Connector (E--)

NO1 Cylinder Ignition Coil Connector

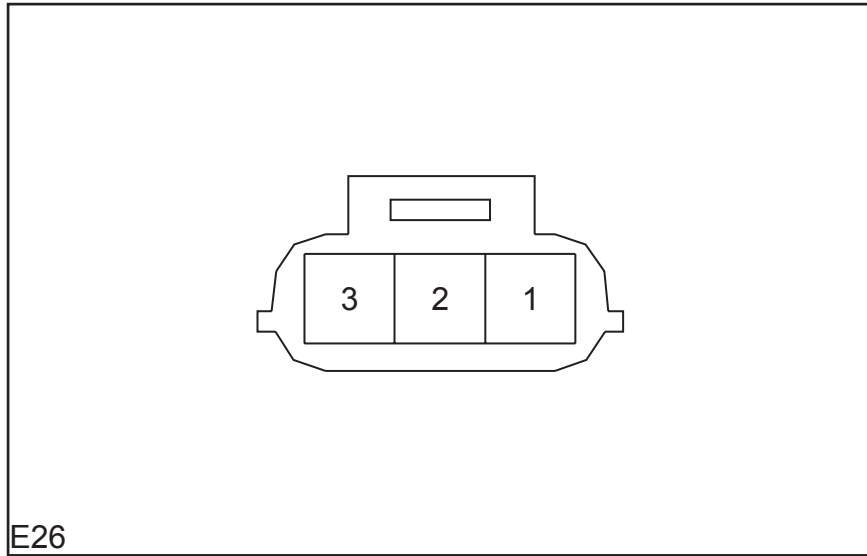

E26

E26 Pin Definition

Pin Number	Wire Width / Color	Function
1	2.00 R/B	Ignition coil control
2	0.85 B/R	Main relay power
3	0.85 B	Ground

Oil Pressure Switch Connector

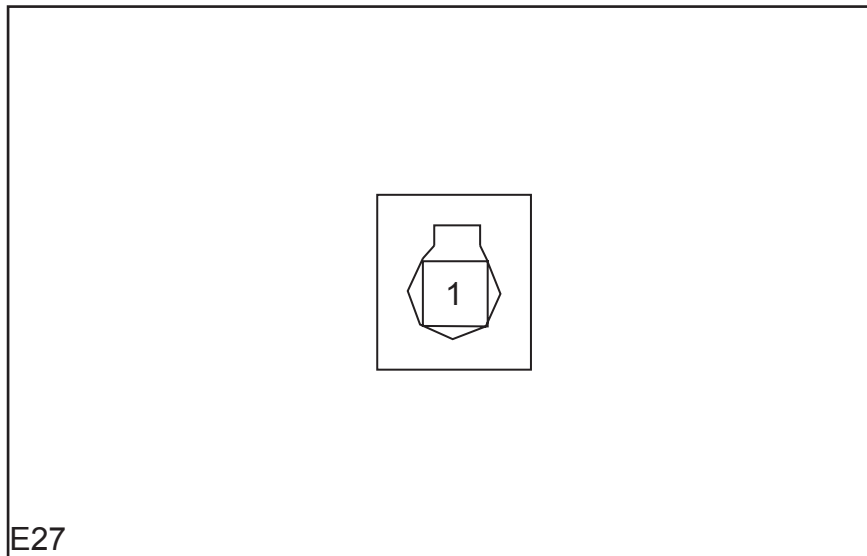

E27

E27 Pin Definition

Pin Number	Wire Width / Color	Function
1	0.85 R/W	Signal

Engine Harness Connector (E--)

A/C Solenoid Switch Connector

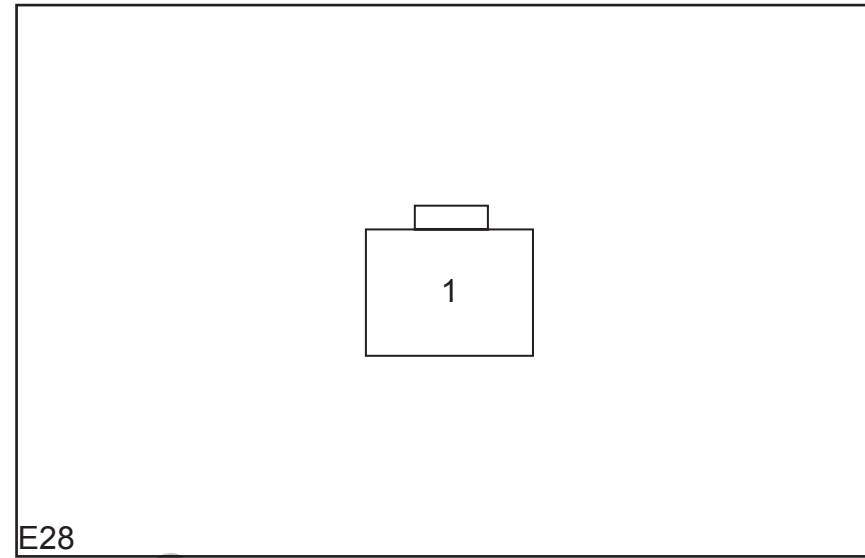

E28

E28 Pin Definition

Pin Number	Wire Width / Color	Function
1	0.50 Y/B	Signal

Alternator Connector

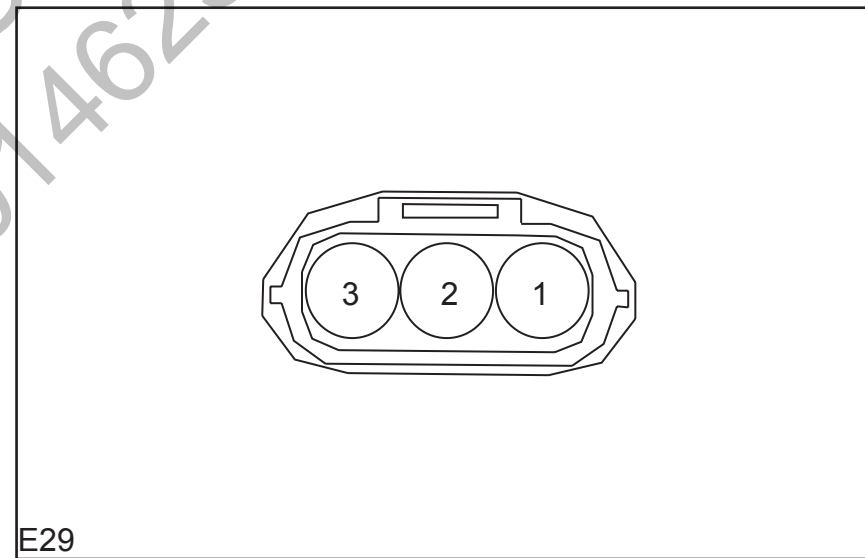

E29

E29 Pin Definition

Pin Number	Wire Width / Color	Function
1	0.85 R	Battery power
2	0.85 B/W	Ignition switch power
3	0.85 W/R	Battery charging indicator

Harness Connector View

Engine Harness Connector (E--)

A/C Pressure Switch Connector

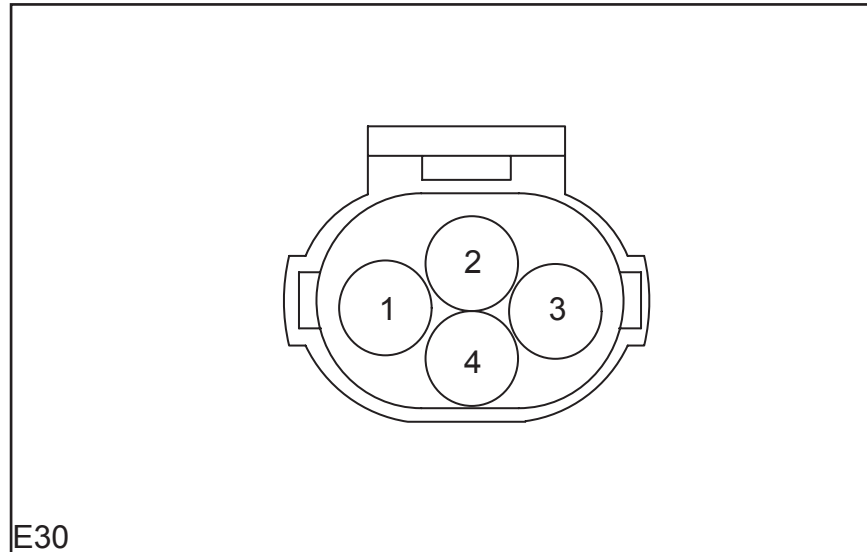

E30 Pin Definition

Pin Number	Wire Width / Color	Function
1	0.50 B	Ground
2	0.50 V/R	A/C pressor switch control
3	0.50 G/V	A/C pressor switch signal
4	0.50 Gr/Y	A/C pressor switch control

Accelerator Pedal Position Connector

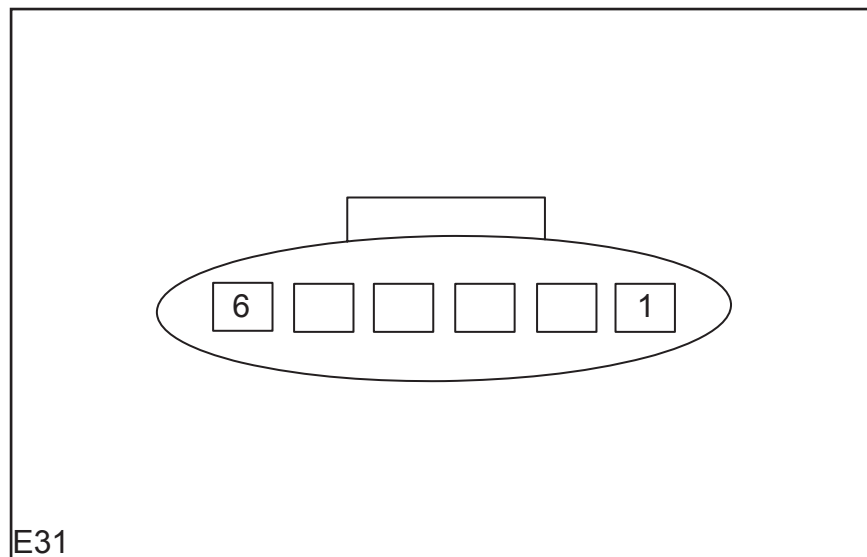

E31 Pin Definition

Pin Number	Wire Width / Color	Function
1	0.50 Br/V	APP signal
2	0.50 Br/R	GND
3	0.50 R/Y	APP control
4	0.50 Br/B	GND
5	0.50 O/BI	Power
6	0.50 R/B	APP power

Engine Harness Connector (E--)

Engine Harness to IP Harness Connector

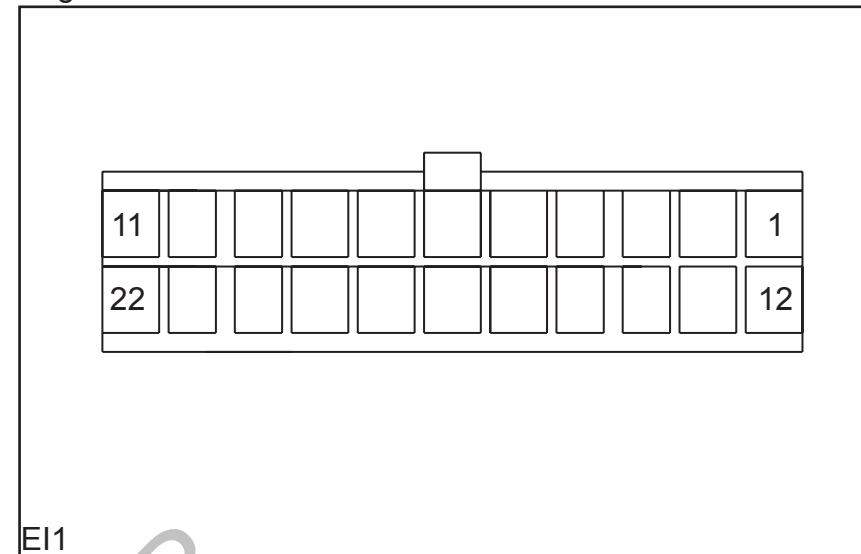

E11 Pin Definition

Pin Number	Wire Width / Color	Function
1	0.50 Gr/Y	A/C switch start signal
2	0.50 Y/B	Oil pressure switch
3	0.50 W/BI	Engine speed signal
4	0.85 W/R	Battery charging indicator
5	0.50 V/W	Engine speed output signal
6	0.50 B/W	Clutch switch signal
7	0.50 G/Gr	Brake lamp switch status signal
8	0.50 P/G	K-line
9	0.50 P	Instantaneous oil consumption signal
10	0.50 W/Y	SVS fault indicator lamp
11	0.50 G/B	Coolant temperature indicator signal
12	0.50 W/B	Engine speed output signal
13	0.50 G/W	Brake switch status signal
14	0.50 P/W	MIL warning indicator lamp
15	0.50 BI/G	EPS switch signal
16	0.50 BI/G	Headlamp signal
17		NC
18		NC
19		NC
20		NC
21	0.50 R/B	Down shift indicator
22	0.50 R/Y	Up shift indicator

Harness Connector View

Engine Harness Connector (E--)

Engine Harness to IP Harness Connector

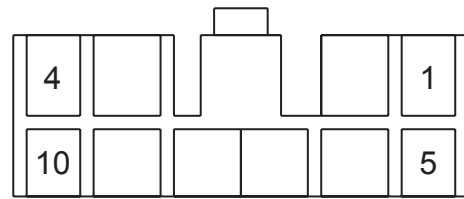

E12

E12 Pin Definition

Pin Number	Wire Width / Color	Function
1	1.25 B/W	IG1 power
1	1.25 BI/W	IG1 power(PEPS)
2	0.85 B/W	Ignition switch power
3	0.85 R	Battery power
4	0.50 G/P	Reverse lamp signal
5	0.50 G/BI	Reverse lamp switch power
6		NC
7	2.00 B/Y	Start motor power
8		NC
9		NC
10		NC

Engine Harness Connector (E--)

Engine Harness to Engine Compartment Harness Connector

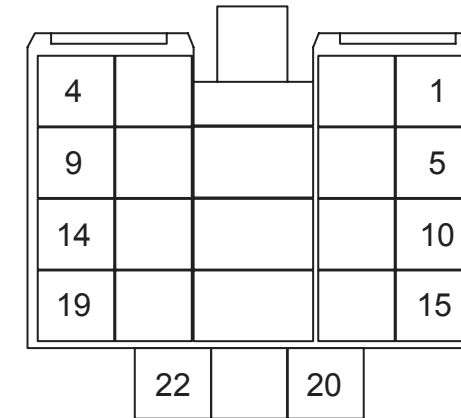

E12

E12 Pin Definition

Pin Number	Wire Width / Color	Function
1	0.85 R/W	A/C compressor power
2	0.85 W/R	High speed fan control
3	0.50 W/B	Low speed fan control
4	0.85 W/BI	Fuel pump control
5	0.85 Y	Main relay control
6	0.50 W/Y	A/C relay control
7	2.00 BI/R	Main relay power
8	0.50 BI/Y	Headlamp open signal
9		NC
10	0.50 G/Y	CAN-L
11	0.50 G/B	CAN-H
12		NC
13		NC
14		NC
15		NC
16		NC
17		NC
18		NC
19		NC
20		NC
21		NC
22		NC

Harness Connector View

Engine Compartment Harness Connector (U--)

Brake Fluid Sensor Connector

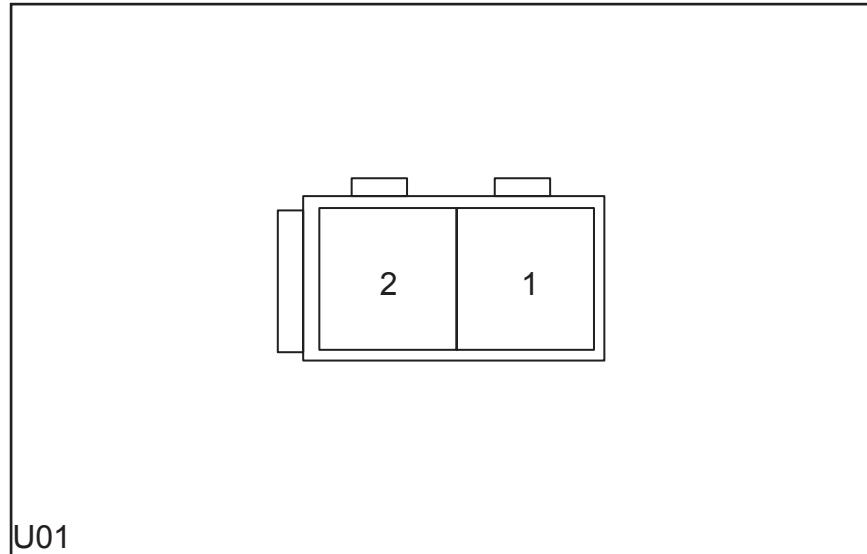

U01

U01 Pin Definition

Pin Number	Wire Width / Color	Function
1	0.50 B	Brake fluid sensor -
2	0.50 P/B	Brake fluid sensor +

Engine Compartment Harness Connector (U--)

EPS Connector

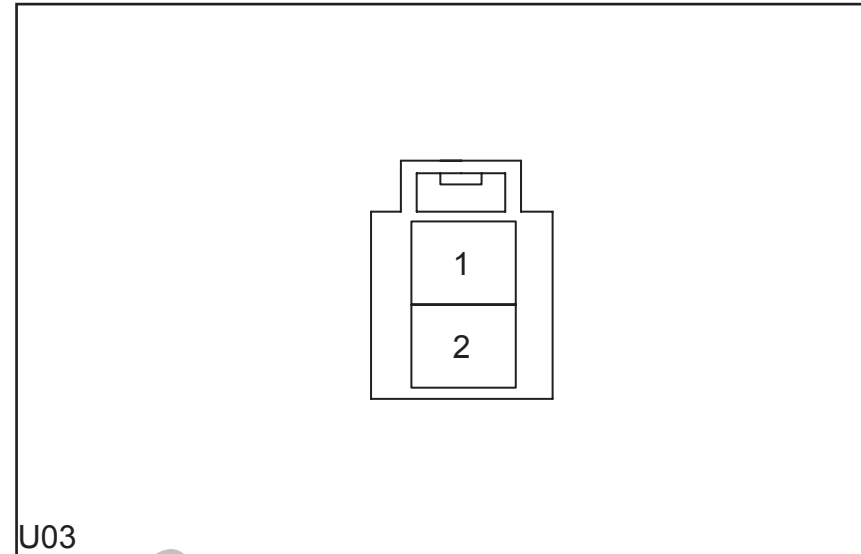

U03

U03 Pin Definition

Pin Number	Wire Width / Color	Function
1	4.00 R	Power
2	4.00 B	Ground

Front Wiper Motor Connector

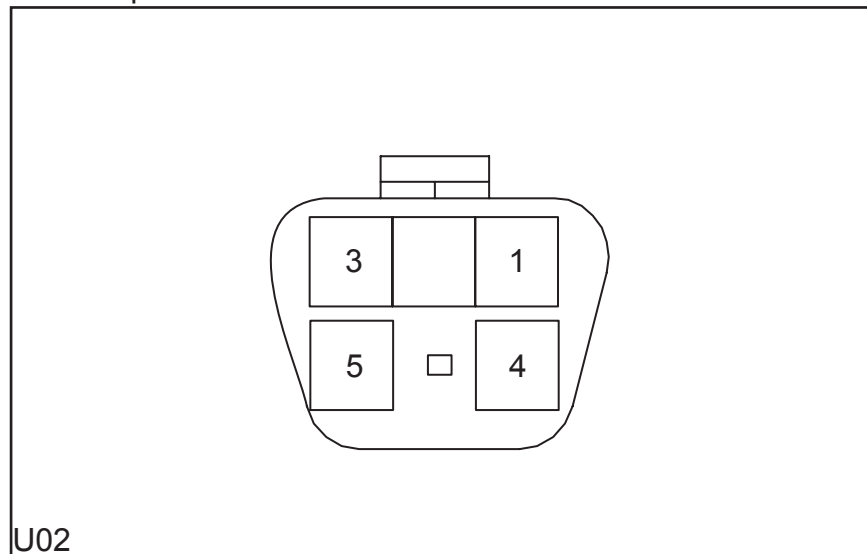

U02

U02 Pin Definition

Pin Number	Wire Width / Color	Function
1	1.25 Gr/B	Wiper high speed
2	0.85 Gr/R	Wiper return
3	0.85 Gr	power
4	0.85 Gr/Y	Wiper low speed
5	1.25 B	Ground

IP Fuse and Relay Box Power Connector

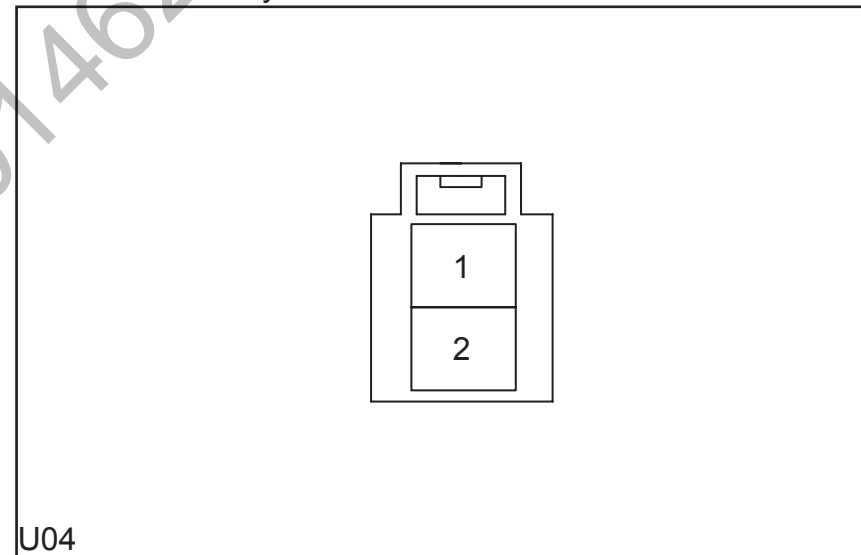

U04

U04 Pin Definition

Pin Number	Wire Width / Color	Function
1	3.00 R	power
2	3.00 R	power

Harness Connector View

Engine Compartment Harness Connector (U--)

LF Daytime Running Lamp Connector

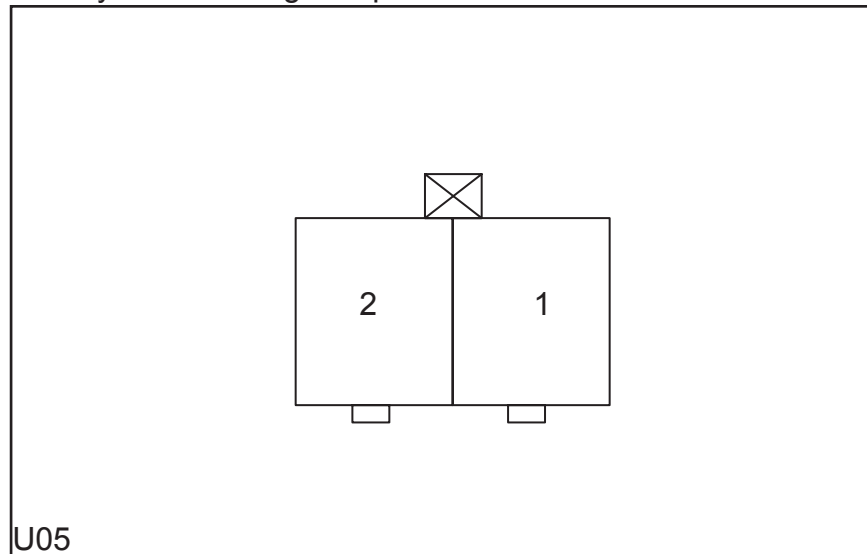

U05

U05 Pin Definition

Pin Number	Wire Width / Color	Function
1	0.50 BI/O	Power
2	0.50 B	Ground

RF Daytime Running Lamp Connector

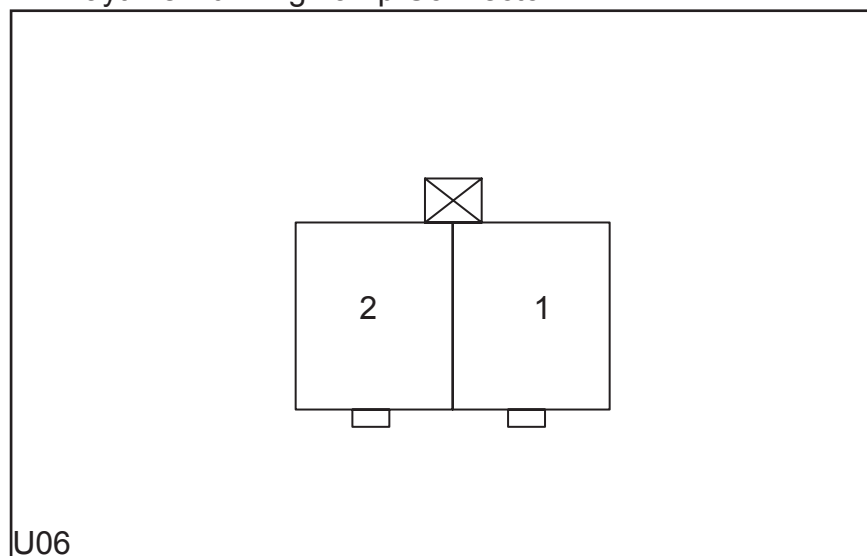

U06

U06 Pin Definition

Pin Number	Wire Width / Color	Function
1	0.50 BI/O	Power
2	0.50 B	Ground

Engine Compartment Harness Connector (U--)

ABS/ESP HCU Connector

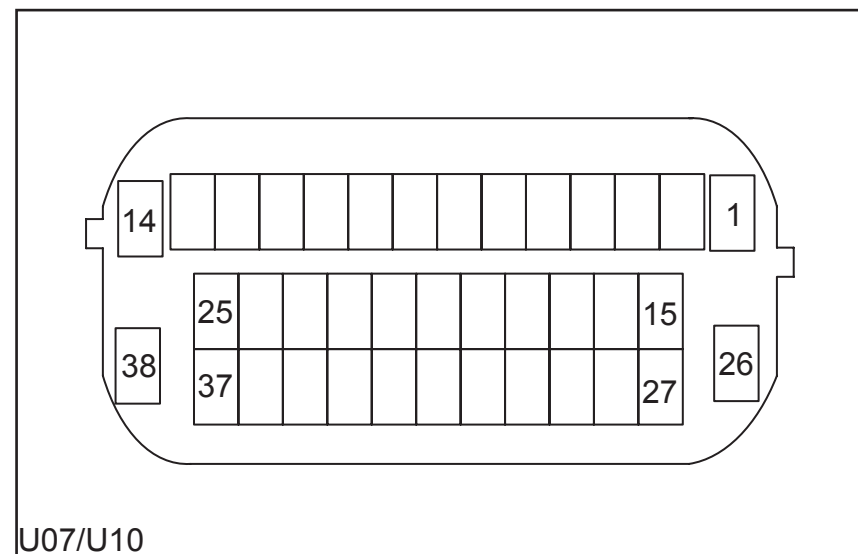

U07/U10

U07/U10 Pin Definition

Pin Number	Wire Width / Color	Function
1	3.00 B	Ground
2		NC
3		NC
4		NC
5		NC
6	0.50 W	Signal
7		NC
8	0.50 Br/Gr	LR wheel speed sensor signal +
9	0.50 G/Gr	Brake signal
10	0.50 Br/G	RR wheel speed sensor signal -
11	0.50 R/B	IG1 Power
12	0.50 W	ABS fault indicator
13	0.50 W/BI	Signal
14	3.00 R/B	Power 12V
15		NC
16		NC
17		NC
18		NC
19	0.50 W/B	Signal
20	0.50 Br/W	LF wheel speed sensor signal +
21	0.50 Br/BI	LR wheel speed sensor signal -
22	0.50 Br/P	RR wheel speed sensor signal +
23	0.50 Br/O	RF wheel speed sensor signal +
24		NC
25	0.50 W/B	Signal
26	3.00 B	Ground
27	0.50 W/G	ESP switch signal
28		NC
29		NC

Harness Connector View

Engine Compartment Harness Connector (U--)

U07/U10 Pin Definition

Pin Number	Wire Width / Color	Function
30		NC
31	0.50 Br/Y	LF wheel speed sensor signal -
32		NC
33	0.50 P/G	K-line
34		NC
35	0.50 Br/B	RF wheel speed sensor signal -
36	0.50 W/G	Brake system fault indicator
37		NC
38	3.00 R	Power 12V

RF Wheel Speed Sensor Connector

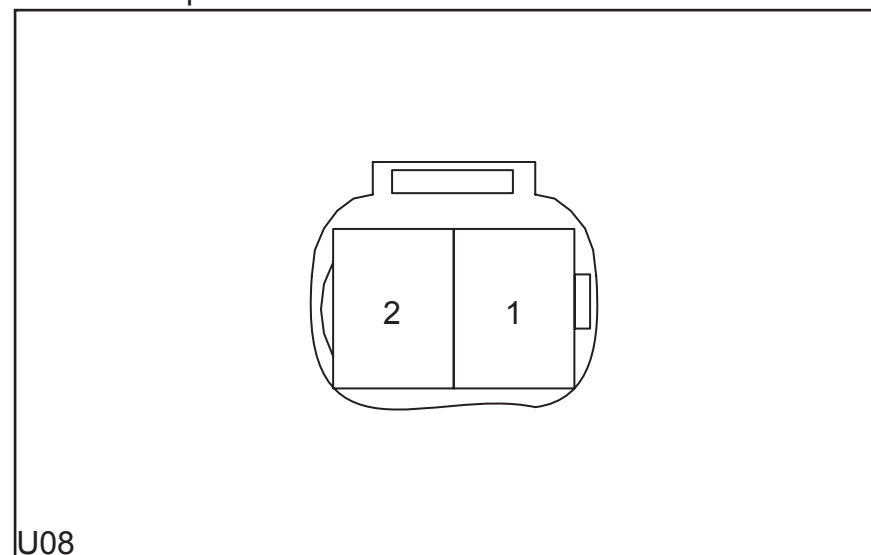

U08 Pin Definition

Pin Number	Wire Width / Color	Function
1	0.50 Br/B	Signal-
2	0.50 Br/O	Signal +

Engine Compartment Harness Connector (U--)

Front Washer Motor Connector

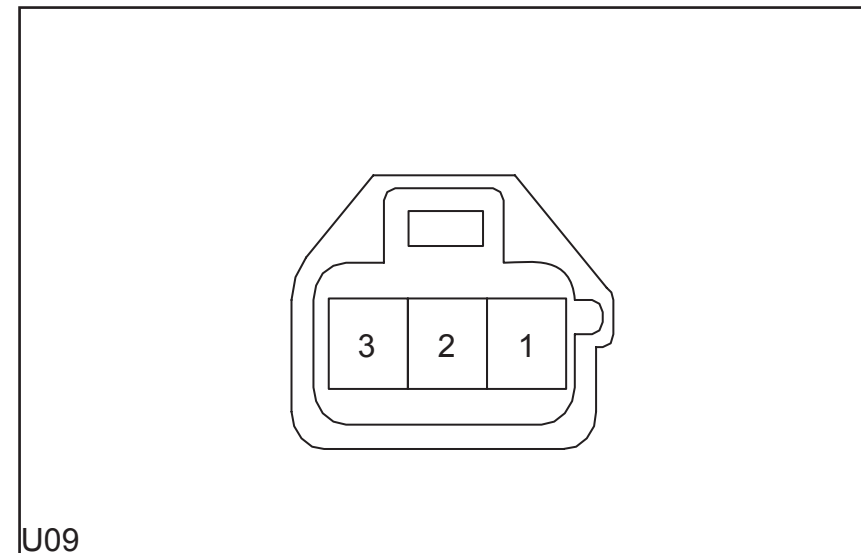

U09 Pin Definition

Pin Number	Wire Width / Color	Function
1		NC
2	0.50 P	Power
3	0.85 Gr	Washer control

RF Combination Lamp Connector

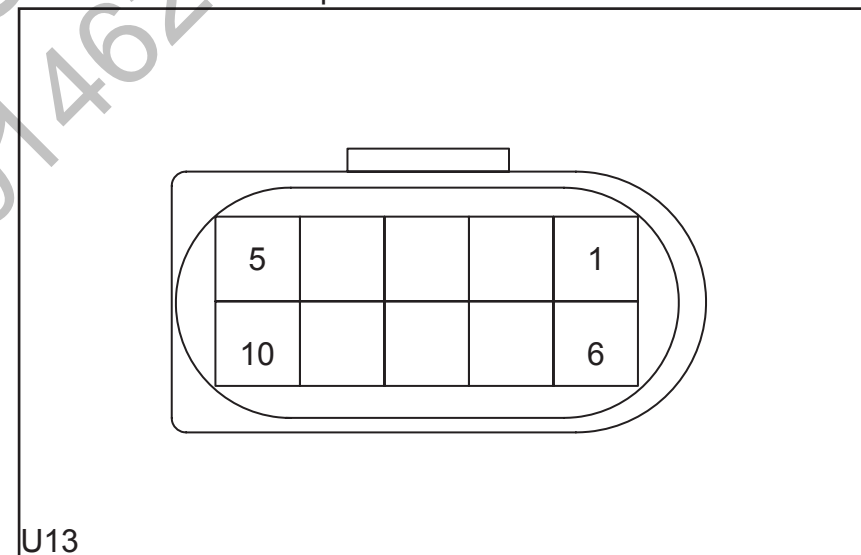

U13 Pin Definition

Pin Number	Wire Width / Color	Function
1		NC
2	0.85 BI/W	High beam lamp power
3	0.85 B	High/low beam/turn lamp GND
4	0.50 BI/Y	Adjust motor power
5		NC
6	0.85 B	Width lamp GND
7	0.50 BI	Width lamp power
8	0.50 Y	Turn lamp power
9	0.85 BI/Y	Low beam lamp power
10		NC

Harness Connector View

Engine Compartment Harness Connector (U--)

RF Insult Sensor Connector

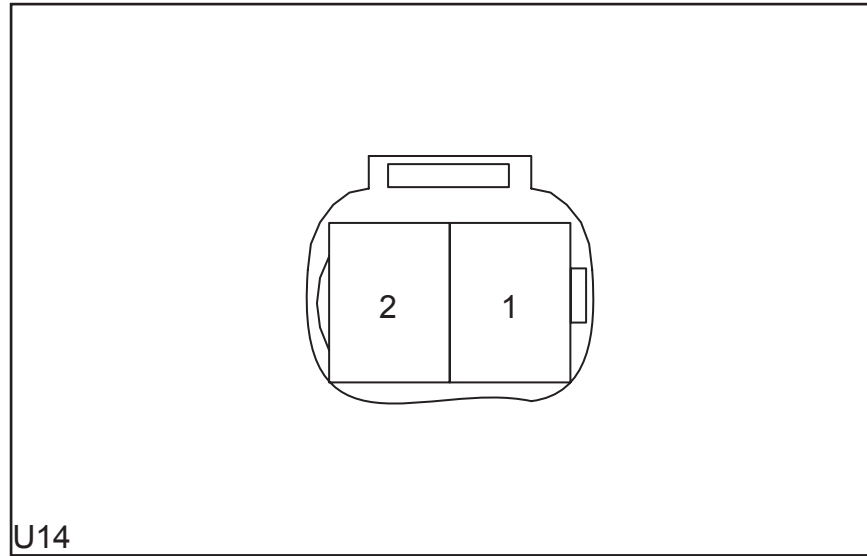

U14 Pin Definition

Pin Number	Wire Width / Color	Function
1	0.50 Y/V	Signal +
2	0.50 Y/Gr	Signal -

Rear Washer Motor Connector

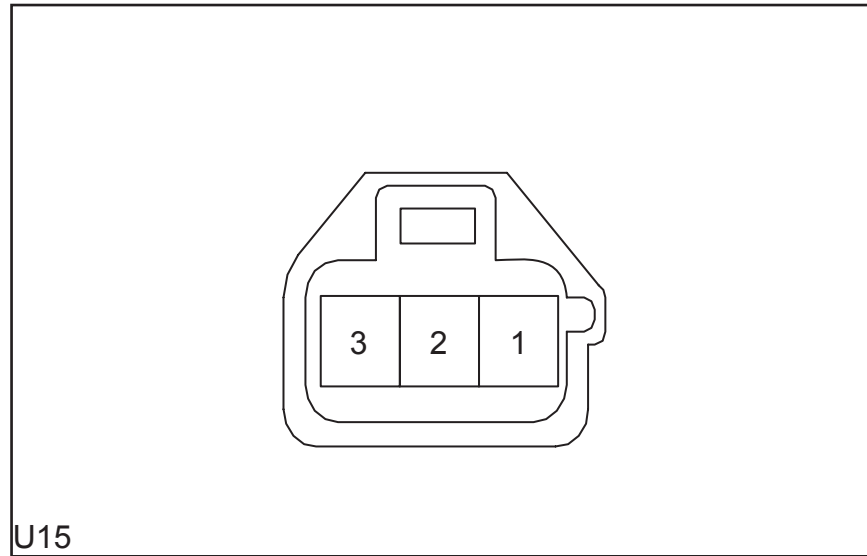

U15 Pin Definition

Pin Number	Wire Width / Color	Function
1		NC
2	0.85 B	Ground
3	0.50 Gr/Bl	Power

Engine Compartment Harness Connector (U--)

Bass Horn Connector

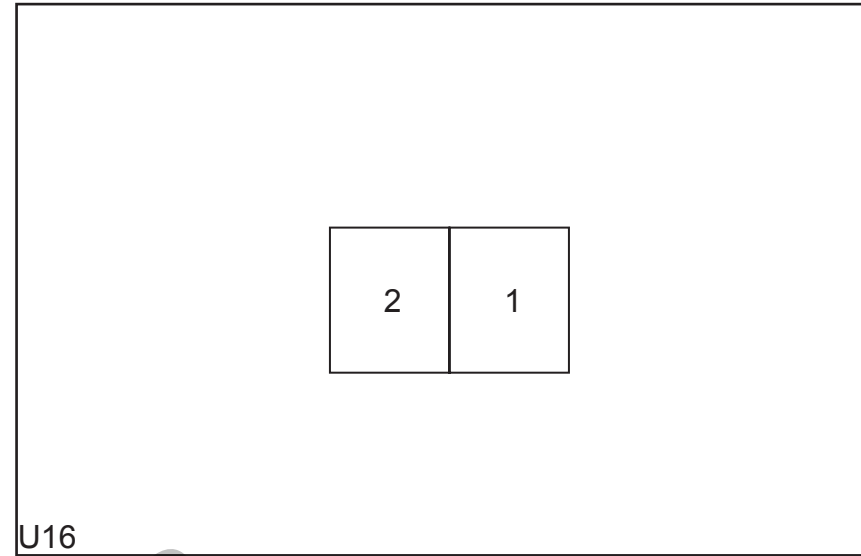

U16 Pin Definition

Pin Number	Wire Width / Color	Function
1	0.85 P/W	Power +
2	0.85 B	Ground

Engine Compartment Cover Switch Connector

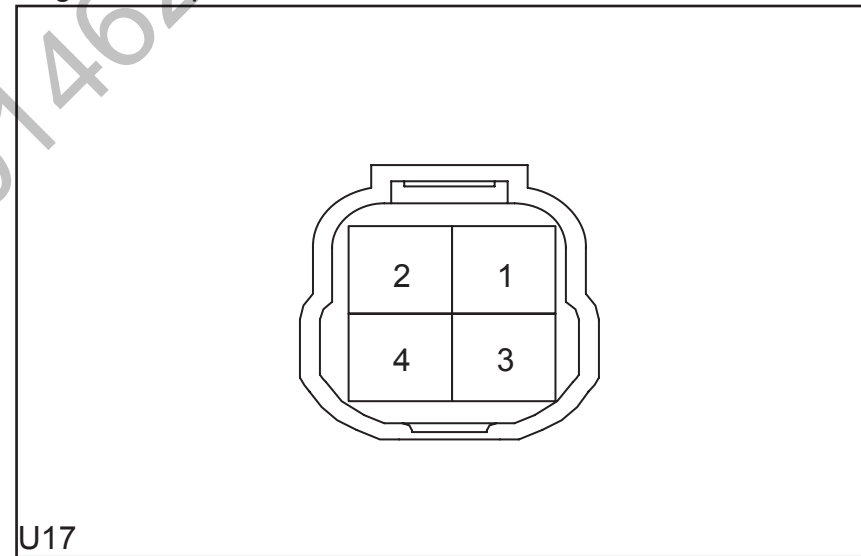

U17 Pin Definition

Pin Number	Wire Width / Color	Function
1	0.50 B	Ground
2	0.50 P/Y	Signal
3		NC
4		NC

Harness Connector View

Engine Compartment Harness Connector (U--)

Outside Temperature Sensor Connector

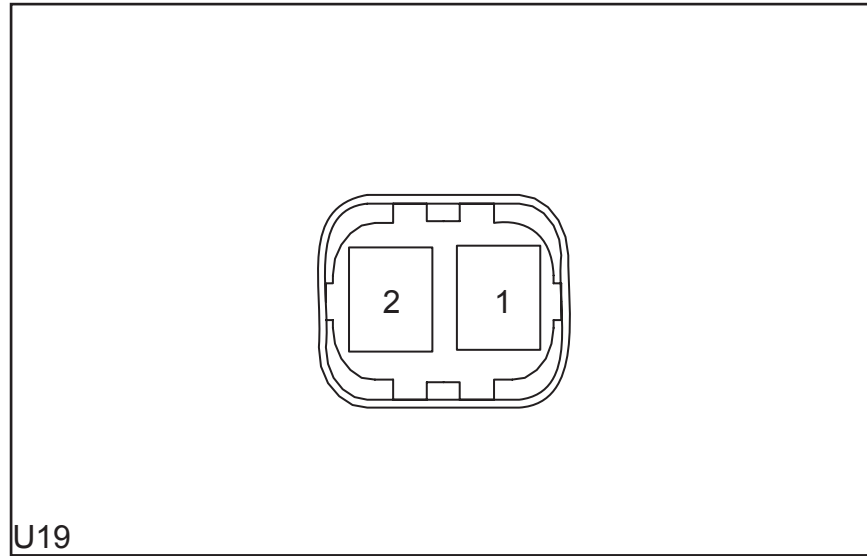

U19

U19 Pin Definition

Pin Number	Wire Width / Color	Function
1	0.50 V/W	Signal
2	0.50 V/Y	Signal

LF Insult Sensor Connector

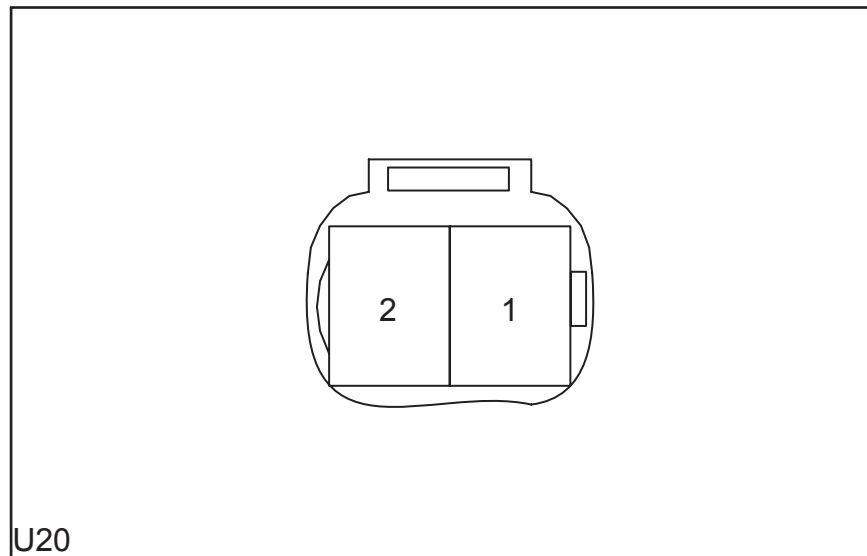

U20

U20 Pin Definition

Pin Number	Wire Width / Color	Function
1	0.50 Y/Br	Signal +
2	0.50 Y/Bl	Signal -

Engine Compartment Harness Connector (U--)

Fan Connector

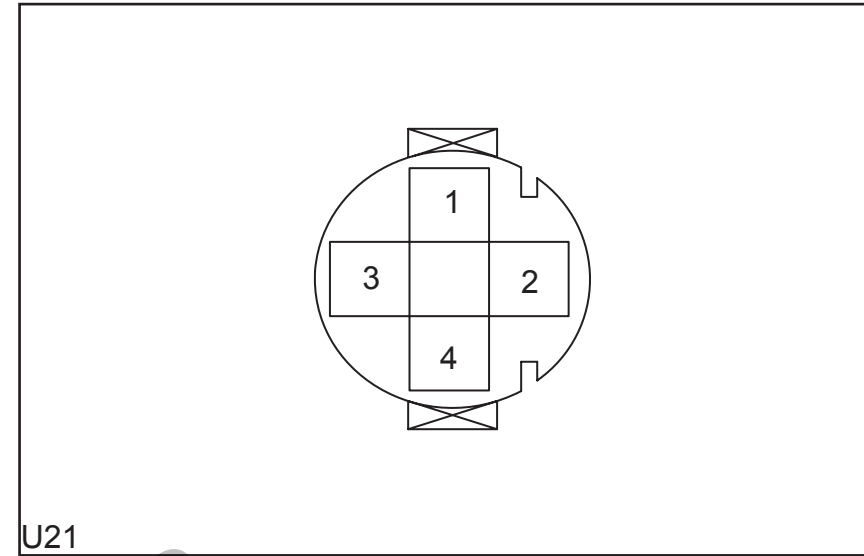

U21

U21 Pin Definition

Pin Number	Wire Width / Color	Function
1	2.00 R/W	High speed fan power +
2	2.00 R/B	Low speed fan power +
3	2.00 B/W	Low speed fan power -
4	2.00 B	Ground

LF Wheel Speed Sensor Connector

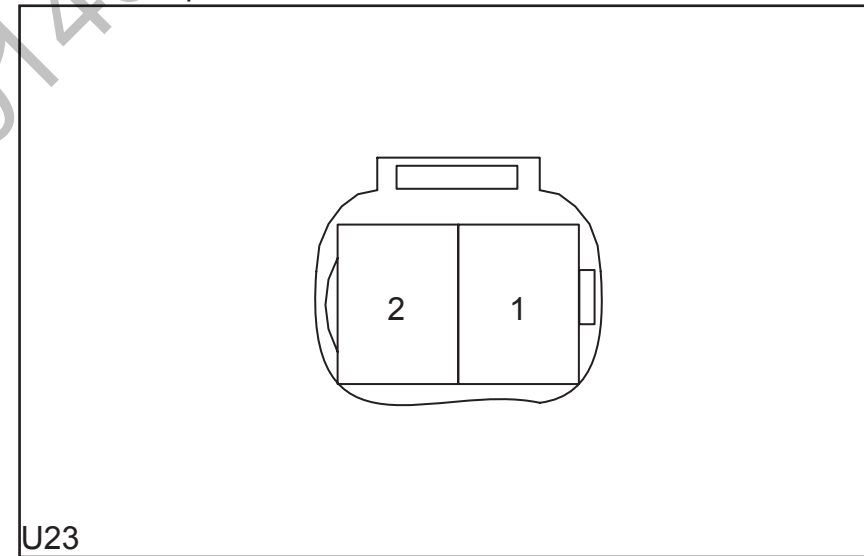

U23

U23 Pin Definition

Pin Number	Wire Width / Color	Function
1	0.50 Br/Y	Signal
2	0.50 Br/W	Signal

Harness Connector View

Engine Compartment Harness Connector (U--)

LF Combination Lamp Connector

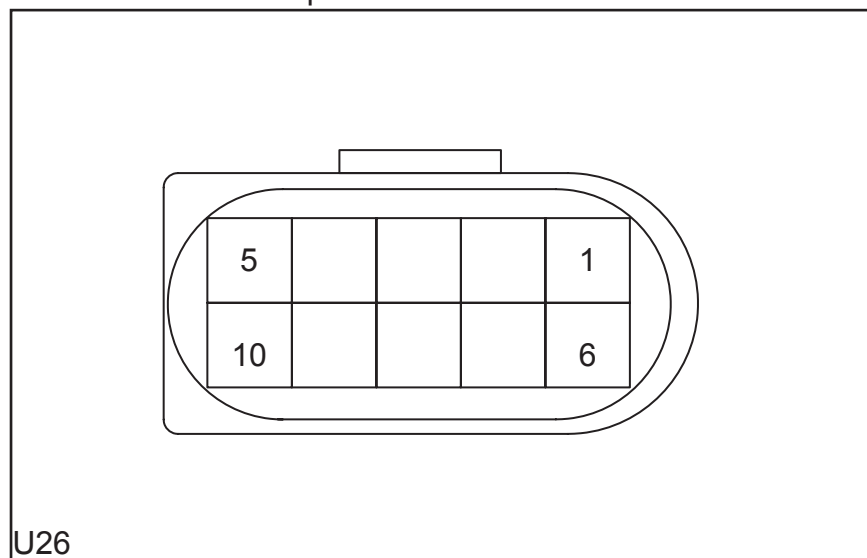

U26

U26 Pin Definition

Pin Number	Wire Width / Color	Function
1		NC
2	0.85 BI/W	High beam lamp power
3	0.85 B	High/low beam/turn lamp GND
4	0.50 BI/Y	Adjust motor power
5		NC
6	0.85 B	Width lamp GND
7	0.50 BI	Width lamp power
8	0.50 W	Turn lamp power
9	0.85 BI/Y	Low beam lamp power
10		NC

Althorn Horn Connector

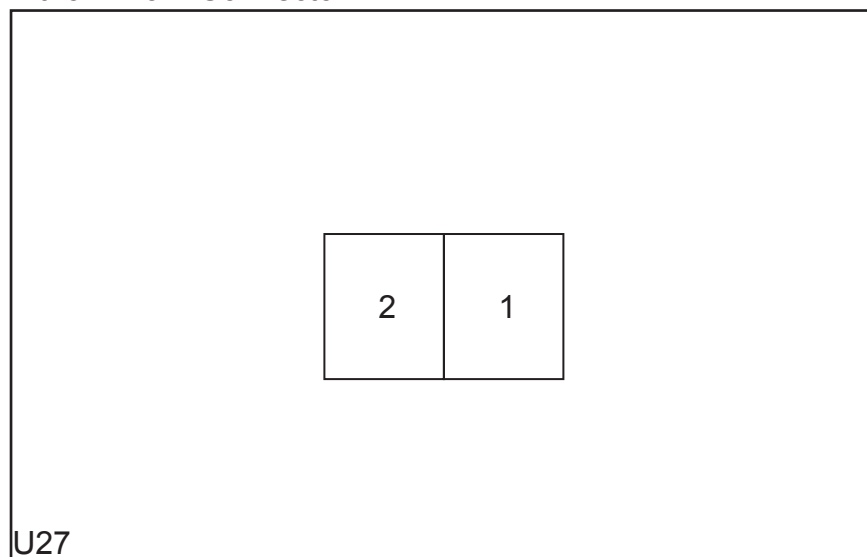

U27

U27 Pin Definition

Pin Number	Wire Width / Color	Function
1	0.85 P/W	Power +
2	0.85 B	Ground

Engine Compartment Harness Connector (U--)

Transmission Harness Connector

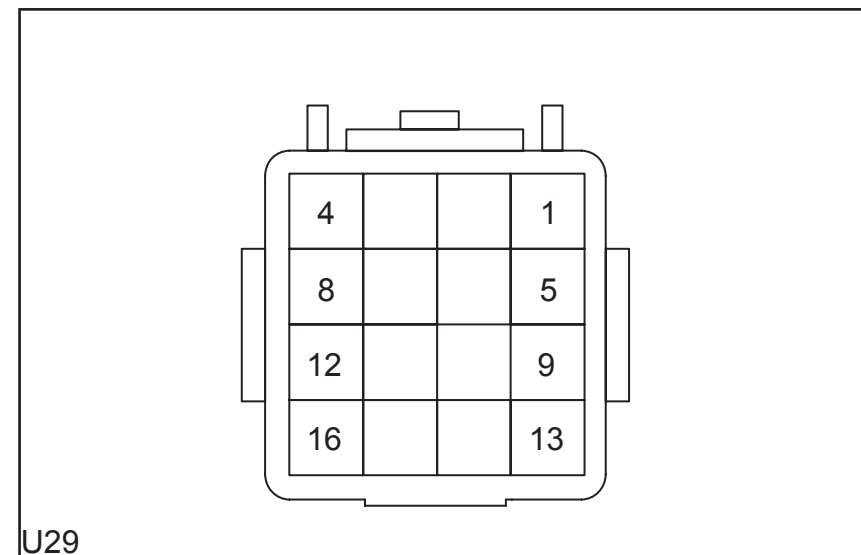

U29

U29 Pin Definition

Pin Number	Wire Width / Color	Function
1	0.85 R/Y	Oil pressure sensor power
2	0.50 G/Y	Oil pressure sensor pressure signal
3	0.85 G	GND
4	0.50 Y/G	Driven wheel speed
5	0.85 Y	Driven cylinder vavle
6	0.85 BI	Drive cylinder vavle
7	0.50 V/W	Drive wheel speed
8	0.85 G	Locking soleniod vavle
9	0.85 BI/R	Speed sensor power
10	0.85 Br	Clutch soleniod vavle
11	0.50 V	Oil tempareture sensor signal
12	0.85 B	Speed sensor 1 ground
13	0.85 B	Oil tempareture sensor ground
14	0.85 B	Oil tempareture sensor ground
15	0.85 B	Speed sensor 2 ground
16	0.85 G	GND

Harness Connector View

Engine Compartment Harness Connector (U--)

Gear Switch Connector

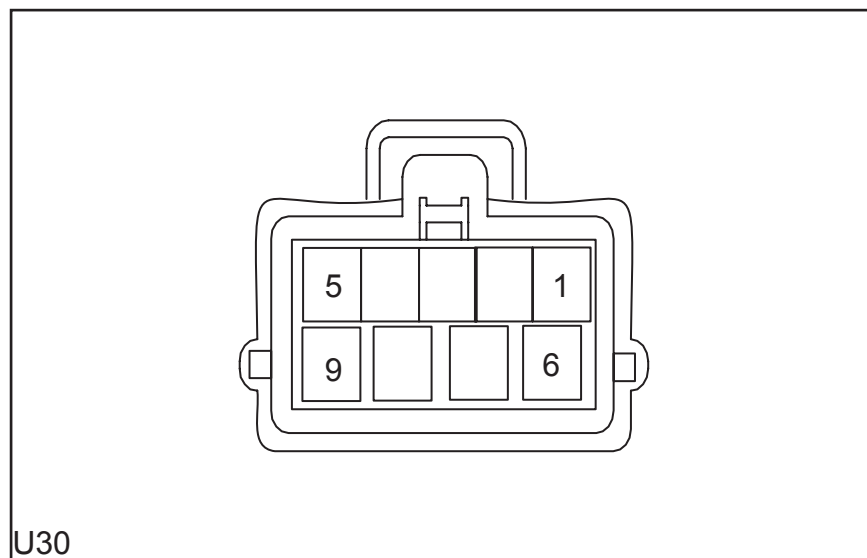

U30 Pin Definition

Pin Number	Wire Width / Color	Function
1	0.50 BI/Y	R gear
2	0.50 W/V	P gear
3	0.50 W	N gear
4	0.50 G/O	S gear
5	0.85 BI/R	Power
6	0.85 B	Ground
7	0.50 Y/BI	D gear
8		NC
9	0.50 B/W	Start motor relay control

Engine Compartment Harness Connector (U--)

TCU(Blue) Connector

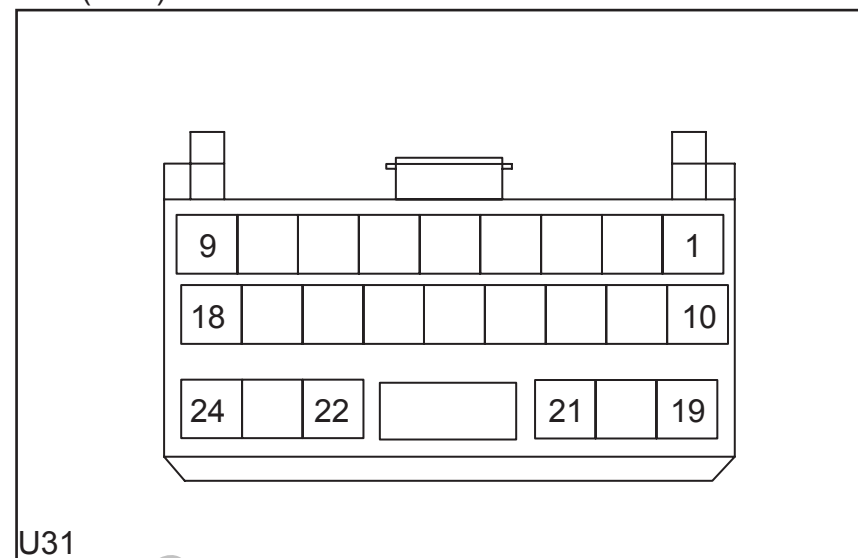

U31 Pin Definition

Pin Number	Wire Width / Color	Function
1	0.85 Br	Clutch solenoid vavle
2	0.85 G	Locking solenoid valve
3		NC
4	0.85 BI	Drive cylinder vavle
5		NC
6	0.85 Y	Driven cylinder vavle
7		NC
8		NC
9	0.85 BI/R	TCM power
10		NC
11	0.50 BI/W	Shift control lock
12	0.50 O/B	Reverse lamp control(CVT)
12	0.50 Br/Y	Reverse lamp control(PEPS)
13	0.50 W/R	CAN-L
13	0.50 W	CAN-L(PEPS)
14		NC
15	0.85 B	Ground
16	0.85 O/B	TCU power control
17	0.50 W/G	TCU diagnostic
18	0.85 BI/R	Power
19		NC
20		NC
21		NC
22		NC
23	0.50 Y/W	TCU power
24	0.50 Y/R	CVT gear indicator

Harness Connector View

Engine Compartment Harness Connector (U--)

TCU(Green) Connector

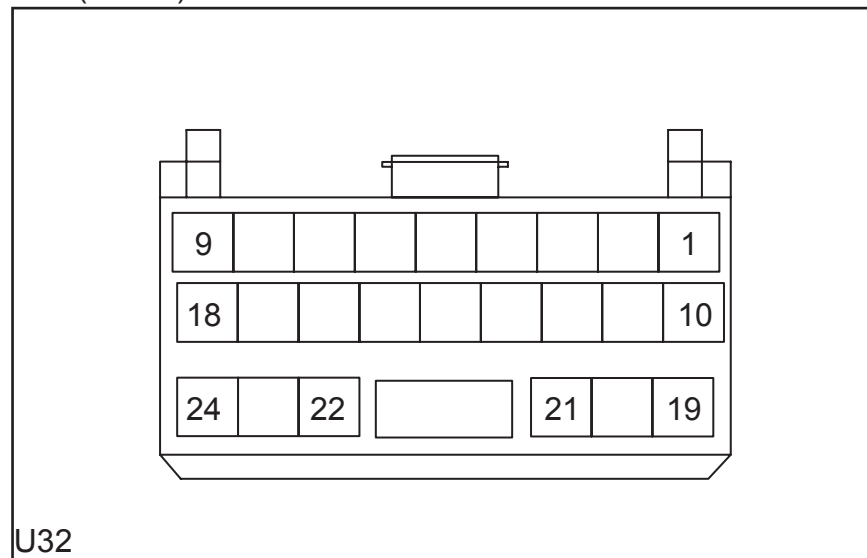

U32 Pin Definition

Pin Number	Wire Width / Color	Function
1	0.85 B	GND
2	0.85 R/Y	Oil pressure sensor Power
3	0.50 G/Y	Oil pressure sensor pressure signal
4	0.50 V	Oil temperature sensor signal
5		NC
6	0.50 G/Gr	Brake signal
7	0.50 G	Shift switch signal
8	0.50 W/V	P gear
9	0.50 Y/BI	D gear
10	0.85 B	Ground
11		NC
12		NC
13		NC
14	0.50 R/W	CAN-H
14	0.50 W/B	CAN-H(PEPS)
15		NC
16	0.50 Y	E/D model signal
17	0.50 BI/Y	R gear
18	0.50 Y/W	Shift switch signal
19	0.85 G	GND
20	0.50 V/W	Drive wheel speed
21	0.50 Y/G	Driven wheel speed
22	0.50 W/G	Reduce speed signal
23	0.50 W	N gear
24	0.50 G/O	D gear

Engine Compartment Harness Connector (U--)

Engine Compartment Harness to IP Harness Connector

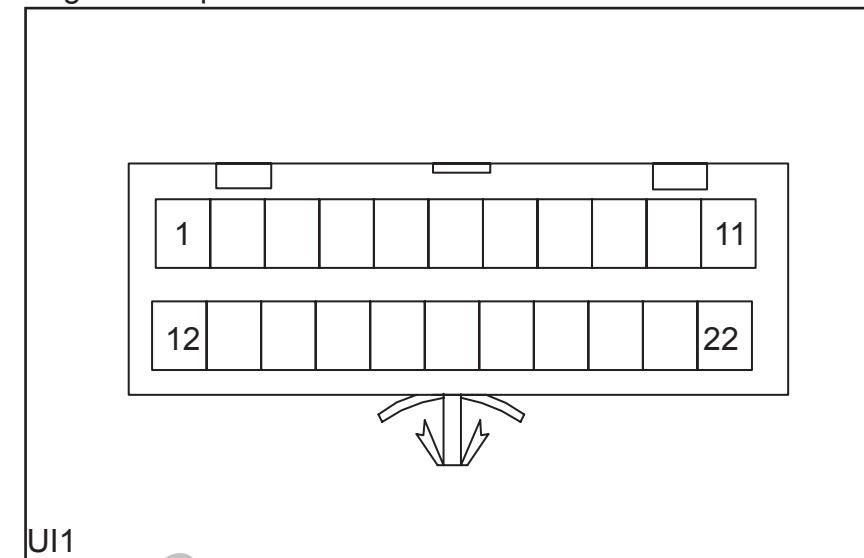

UI1 Pin Definition

Pin Number	Wire Width / Color	Function
1	0.50 V/W	Outside temperature sensor signal -
2	0.50 V/Y	Outside temperature sensor signal +
3	0.50 P/Y	Engine compartment cover open signal
4	0.50 W/BI	Vehicle speed signal
5	0.50 P/B	Brake fluid indicator signal
6	0.50 BI/V	Low beam lamp relay control
7	0.50 BI/O	High beam lamp relay control
8		NC
9	0.50 P/W	Horn switch
10	0.50 G/Gr	Brake signal
11	0.50 BI/Y	Adjust motor +
12	0.50 P/G	ABS K-line
13	0.50 Br/P	RR wheel speed sensor signal +
14	0.50 Br/G	RR wheel speed sensor signal -
15	0.50 Br/Gr	LR wheel speed sensor signal +
16	0.50 Br/BI	LR wheel speed sensor signal -
17	0.50 W/G	Brake system fault indicator
18	0.50 W	ABS fault indicator
19	0.50 Y/BI	LF insult sensor signal -
20	0.50 Y/Br	LF insult sensor signal +
21	0.50 Y/Gr	RF insult sensor signal -
22	0.50 Y/V	RF insult sensor signal +

Harness Connector View

Engine Compartment Harness Connector (U--)

Engine Compartment Harness to IP Harness(MT) Connector

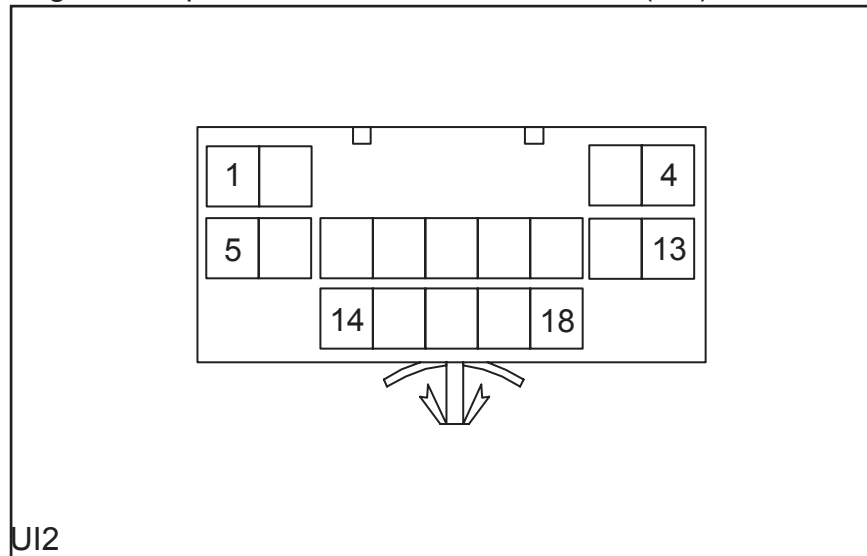

UI2

UI2 Pin Definition

Pin Number	Wire Width / Color	Function
1	0.85 Gr	Wiper/washer motor power
2	1.25 Gr/B	Wiper high speed
3	0.85 Gr/Y	Wiper low speed
4	0.85 Gr/R	Wiper return
5	1.25 R/W	Fuel bump power
6	0.50 Gr/Bl	Rear washer motor power
7	0.50 Bl/W	High beam lamp indicator
8	0.50 Bl/Y	Low beam lamp indicator
9	0.50 Bl	Width lamp power +
10	0.50 Bl/O	LF daytime lamp power +
11	0.50 P	Washer motor power -
12		NC
13		NC
14	0.50 R/B	ABS-ECU power
15	0.50 W	LF turn lamp power
16	0.50 Y	RF turn lamp power
17		NC
18		NC

Engine Compartment Harness Connector (U--)

Engine Compartment Harness to IP Harness(CVT) Connector

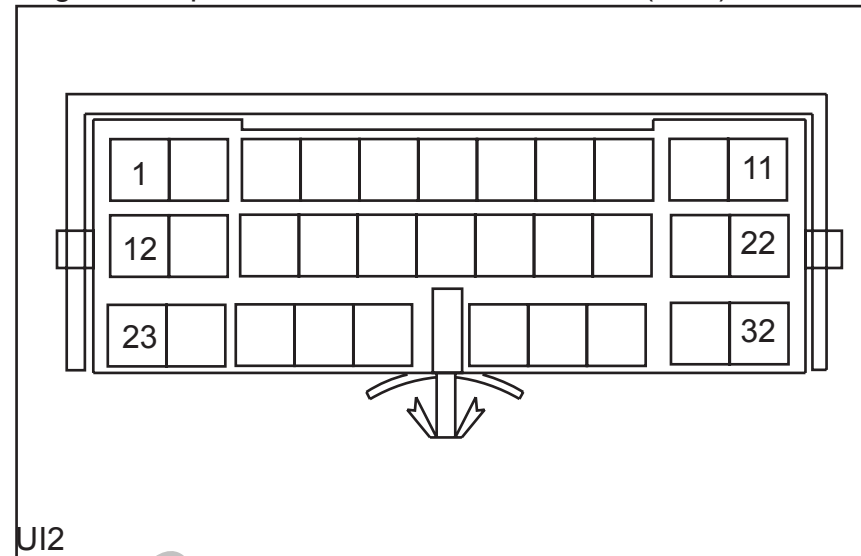

UI2

UI2 Pin Definition

Pin Number	Wire Width / Color	Function
1	0.85 Gr	Wiper/washer motor power
2	1.25 Gr/B	Wiper high speed power +
3	0.50 Bl/W	High-beam lamp indicator
4	0.50 Bl/Y	Low-beam lamp indicator
5	0.50 Bl	Width lamp power +
6	0.50 G/Bl	Daytime running lamp power
7	0.50 P	Washer power -
8	0.50 O/B	Power request signal
9	0.50 Y/W	TCM power
10	0.85 Gr/Y	Wiper low speed power +
11	0.85 Gr/R	Wiper return
12	1.25 R/W	Fule pump power +
13	0.85 Bl/R	12V DC
14	0.50 R/B	ABS ECU power
15	0.50 W	Turn left lamp power
16	0.50 Y	Turn right lamp power
17	0.50 Gr/Bl	Rear washer motor power
18	0.50 Y/R	CVT gear indicator
19	0.50 B/W	Start motor relay control
20	0.50 Br/Y	Reverse lmap control(CVT)
21	0.85 B	GND
22	0.85 B	GND
23	0.50 W	CAN_L
24	0.50 W/B	CAN_H
25	0.50 W/G	Reduced speed signal
26	0.50 G	Shift switch signal
27	0.50 Y	Shift switch signal

Harness Connector View

Engine Compartment Harness Connector (U--)

UI2 Pin Definition

Pin Number	Wire Width / Color	Function
28	0.50 BI/W	Shift control lock
29	0.50 Y/W	E/D model
30	0.50 W/G	CVT diagnostic
31	2.00 R/G	Power(PEPS)
32	1.25 R/P	Power(PEPS)

Engine Compartment Harness to IP Harness Connector

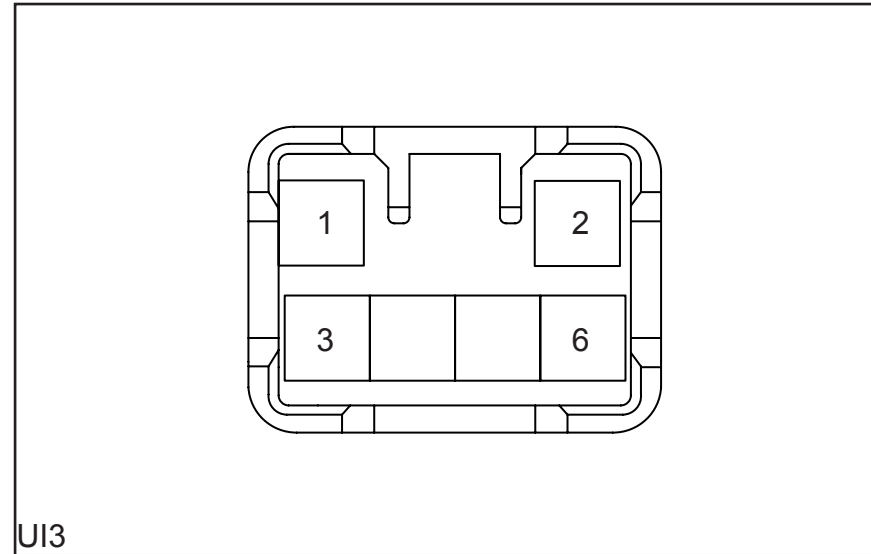

UI3 Pin Definition

Pin Number	Wire Width / Color	Function
1	0.50 W/G	ESP switch signal
2		NC
3	0.50 W/B	CAN-L
4	0.50 W/BI	CAN-H
5	0.50 W/B	Signal
6	0.50 W	Signal

Engine Compartment Harness Connector (U--)

Engine Compartment Harness to Engine Harness Connector

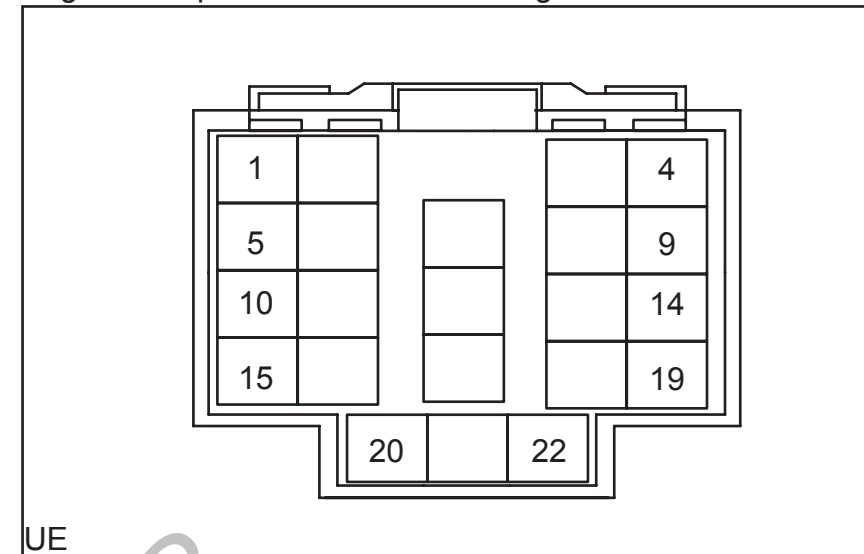

UE Pin Definition

Pin Number	Wire Width / Color	Function
1	0.85 R/W	A/C compressor power
2	0.85 W/R	High speed fan control
3	0.50 W/B	Low speed fan control
4	0.85 W/BI	Fuel pump control
5	0.85 W/G	Main relay control
6	0.50 W/Y	A/C relay control
7	2.00 BI/R	Main relay power
8	0.50 BI/Y	Headlamp open signal
9		NC
10	0.50 W/R	CAN-L
10	0.50 W	CAN-L(PEPS)
11	0.50 R/W	CAN-H
11	0.50 W/B	CAN-H(PEPS)
12		NC
13		NC
14		NC
15		NC
16		NC
17		NC
18		NC
19		NC
20		NC
21		NC
22		NC

Harness Connector View

Instrument Harness Connector (I--)

EPS Connector

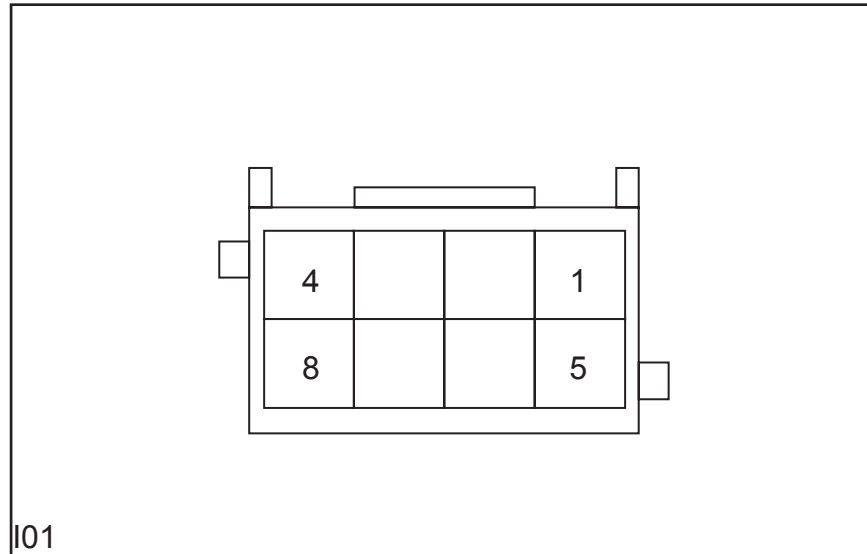

I01

I01 Pin Definition

Pin Number	Wire Width / Color	Function
1	0.50 Y	Power
2	0.50 W/B	CAN-H
2	0.50 W/B	CAN-L(PEPS)
3	0.50 O/G	Vehicle signal input
4	0.50 W/B	Engine speed signal input
5	0.50 W	CAN-L
5	0.50 W/BI	CAN-H(PEPS)
6	0.50 G/W	EPS fault warning
7	0.50 G	EPS idle raise
8	0.50 W/G	EPS fault diagnosis communication

Instrument Harness Connector (I--)

Instrument Cluster-2 Connector

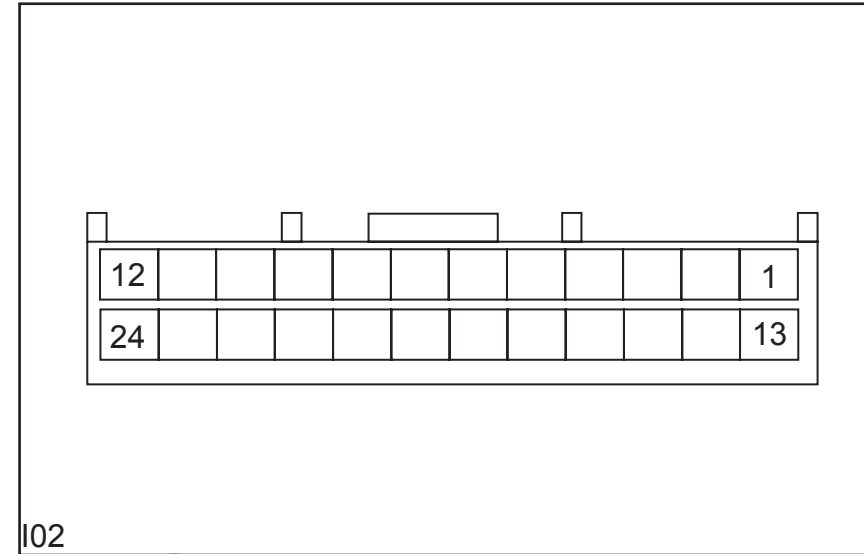

I02

I02 Pin Definition

Pin Number	Wire Width / Color	Function
1	0.50 W/Y	SVS fault indicator
2	0.50 W/G	EBD fault indicator
3	0.50 P/B	Brake system fault indicator
4	0.50 G/P	Parking brake indicator
5	0.50 Y/B	Oil pressor indicator
6	0.50 B/W	ESCL fault indicator(PEPS)
7	0.50 BI/Y	Low beam lamp indicator
8	0.50 W	Turn left signal indicator
9	0.50 Y/R	CVT gear indicator
10	0.50 B	Ground
11	0.50 R/Y	Instrument power
12	0.50 R/B	Power
13	0.50 W	PEPS fault indicator(PEPS)
14	0.50 W/B	CAN-L(PEPS)
15	0.50 W/BI	CAN-H(PEPS)
16	0.50 Gr/B	Four doors ajar indicator(PEPS)
17	0.50 W	Two doors ajar indicator
17		NC(PEPS)
18	0.50 P/Y	Fuel level indicator
19	0.50 W/R	Instantaneous oil consumption signal
20	0.50 G	Coolant temperature sensor signal
21	0.50 BI	Background lamp power
22	0.50 W/B	Engine speed signal input
23	0.50 W/BI	Vehicle speed signal
24	0.50 Br	IMMO fault indicator

Harness Connector View

Instrument Harness Connector (I--)

Instrument Cluster-1 Connector

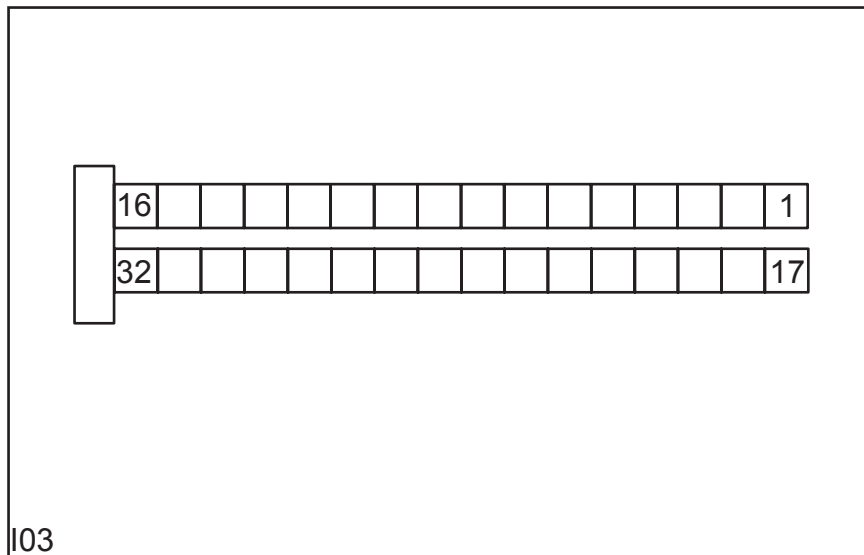

I03 Pin Definition

Pin Number	Wire Width / Color	Function
1	0.50 R/B	Up shift indicator
2	0.50 R/Y	Down shift indicator
3	0.50 Gr/W	Right reverse radar signal
4	0.50 W/B	Reverse radar/fuel sensor ground
5	0.50 G/P	Reverse lamp signal
6	0.50 Gr/R	Left reverse radar signal
7	0.50 R/Y	Reverse radar signal
8	0.50 V/W	Engine speed signal
9	0.50 O/G	Speed pulse signal output
10	0.50 Gr/BI	Central lock signal
10		NC
11	0.50 B/V	RR door ajar signal
12	0.50 B/O	LR door ajar signal
13	0.50 B/Y	RF door ajar signal
14	0.50 B/W	LF door ajar signal
15	0.50 V/Br	Speaker sounding control
16	0.50 V/Y	Speaker sounding enable
17	0.50 W/Br	Passenger seat belt ajar indicator
18	0.50 W/G	Driver seat belt ajar indicator
19	0.50 W/B	ESP Signal(PEPS)
20	0.50 P/Y	Engine compartment cover ajar indicator
21	0.50 B/P	Trunk ajar indicator
22	0.50 P	Rear defroster indicator
23	0.85 W/R	Battery charging indicator
24	0.50 G/W	EPS fault indicator
25	0.50 W	ABS fault indicator
26	0.50 G	SRS fault indicator
27	0.50 BI	Width lamp indicator
28	0.50 G/Br	Rear fog lamp indicator

Instrument Harness Connector (I--)

Pin Number	Wire Width / Color	Function
29	0.50 BI/W	High beam lamp indicator
30	0.50 Y	Turn right lamp indicator
31		NC
32	0.50 P/W	MIL Warning indicator

Interior Lighting Adjust Switch Connector

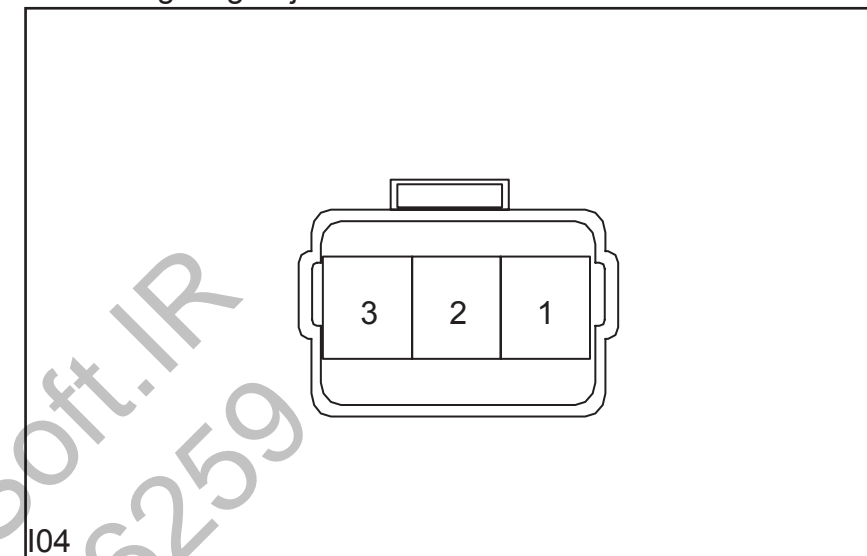

I04 Pin Definition

Pin Number	Wire Width / Color	Function
1	0.50 BI	Background lamp power
2	0.50 BI	Ignition switch power
3	0.50 B	Ground

Harness Connector View

Instrument Harness Connector (I--)

Rearview Mirror Adjust Switch Connector

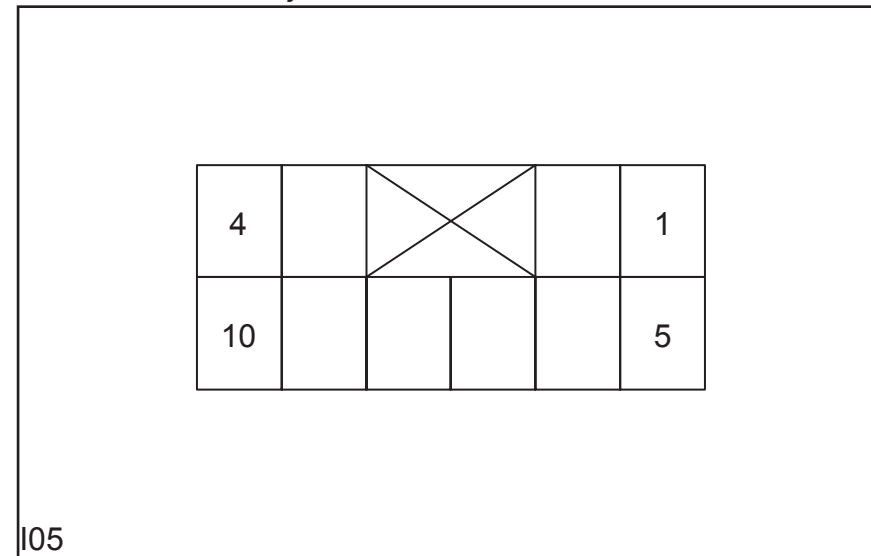

I05

I05 Pin Definition

Pin Number	Wire Width / Color	Function
1	0.50 B	Ground
2	0.50 Y/W	Rearview operation
3	0.50 Y/P	ACC power
4	0.50 BI	Background lamp power
5	0.50 Y/Br	Left rearview left/right power
6	0.50 Y/G	Left rearview up/down power
7		NC
8		NC
9	0.50 Y/BI	Rigt rearview up/down power
10	0.50 Y/Gr	Rigt rearview left/right power

Central Locking Switch Connector

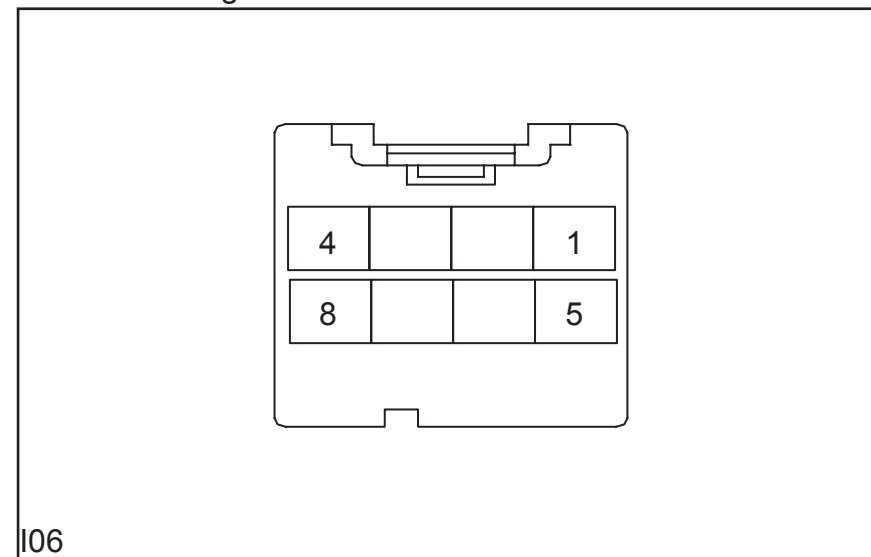

I06

Instrument Harness Connector (I--)

I06 Pin Definition

Pin Number	Wire Width / Color	Function
1		NC
2		NC
3	0.50 B	Ground
4	0.50 BI	Background lamp power
5	0.50 Br/Gr	Lock signal
6	0.50 Br/BI	Unlock signal
7		NC
8		NC

Low-beam Lamp Adjust Switch Connector

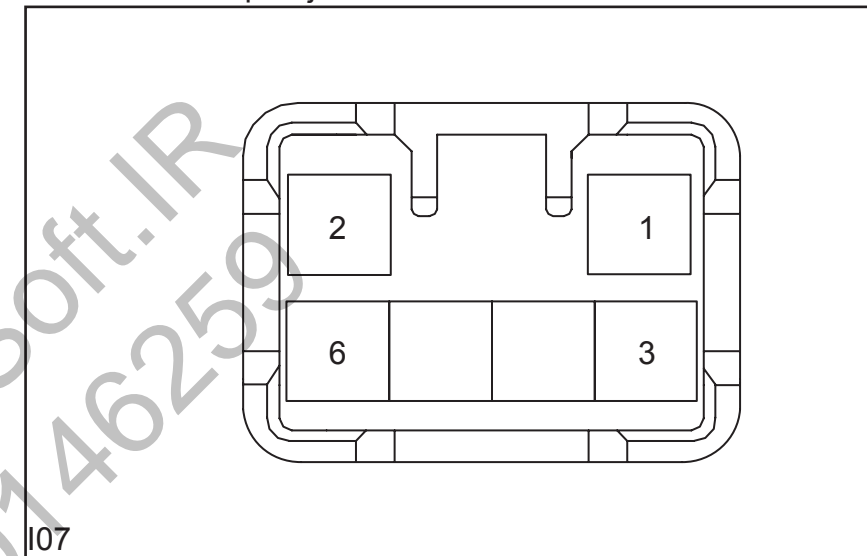

I07

I07 Pin Definition

Pin Number	Wire Width / Color	Function
1	0.50 B	Ground
2	0.50 BI/Y	Headlamp highly adjust
3		NC
4	0.50 BI	Background lamp power
5		NC
6	0.50 BI	Background lamp power

Harness Connector View

Instrument Harness Connector (I--)

Ignition Switch Connector

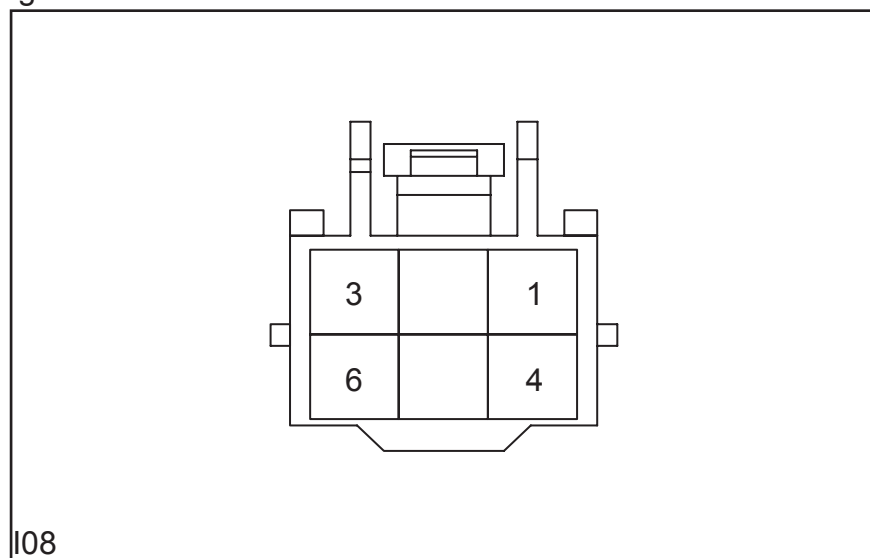

I08 Pin Definition

Pin Number	Wire Width / Color	Function
1	2.00 R/B	ACC power
2	2.00 R/Y	IG1 power
3	3.00 R	Battery power
4	2.00 R/G	IG2 power
5	3.00 R/W	Battery power
6	2.00 R/BI	Start power

IMMO ECU-A Connector

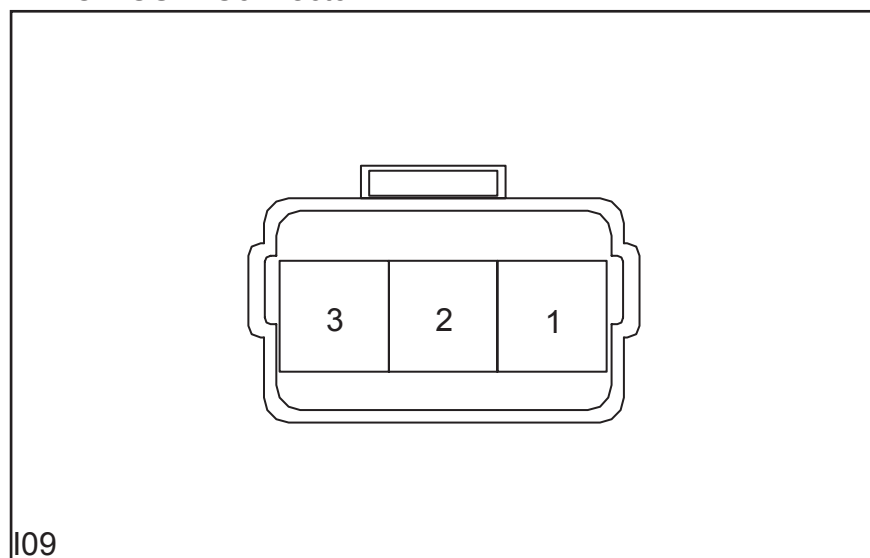

I09 Pin Definition

Pin Number	Wire Width / Color	Function
1		NC
2	0.50 Br/Y	Key recogniton signal
3	0.50 Br/W	Key recogniton signal

Instrument Harness Connector (I--)

IMMO ECU-B Connector

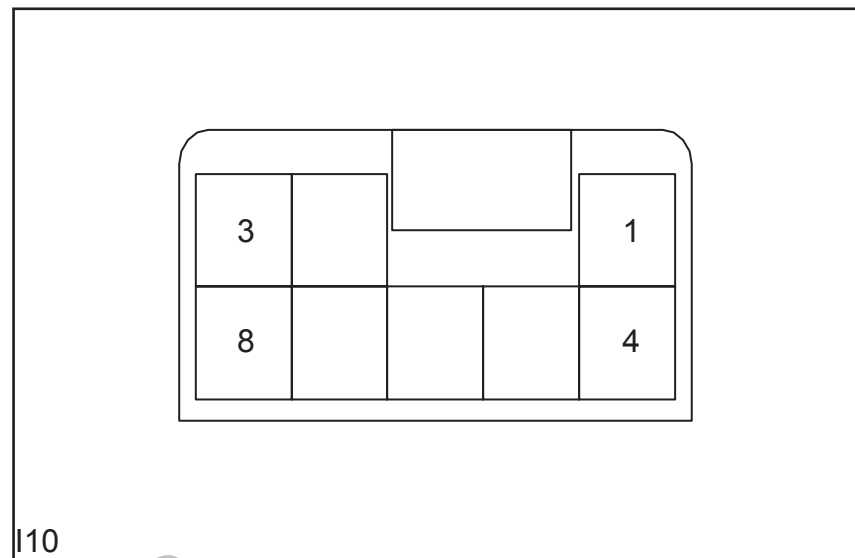

I10 Pin Definition

Pin Number	Wire Width / Color	Function
1		NC
2		NC
3	0.50 Br	Power
4	0.50 P/G	K-line
5		NC
6	0.50 Br	IMMO fault indicator
7	0.50 BI/W	Power
8	0.50 B	Ground

Harness Connector View

Instrument Harness Connector (I--)

Wiper Combination Switch-A Connector

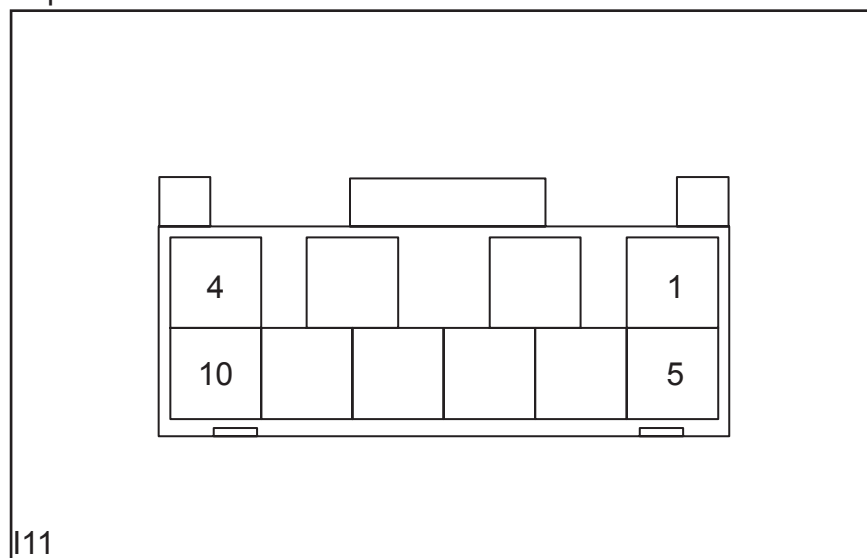

I11 Pin Definition

Pin Number	Wire Width / Color	Function
1	1.25 Gr/B	Wiper High speed
2	0.85 Gr/Y	Wiper low speed
3	0.85 Gr	Power
4	0.85 Gr/R	Rear Wiper return
5		NC
6		NC
7		NC
8		NC
9	0.50 P/W	Horn control
10	0.50 Gr/BI	Rear washer motor power

Wiper Combination Switch-B Connector

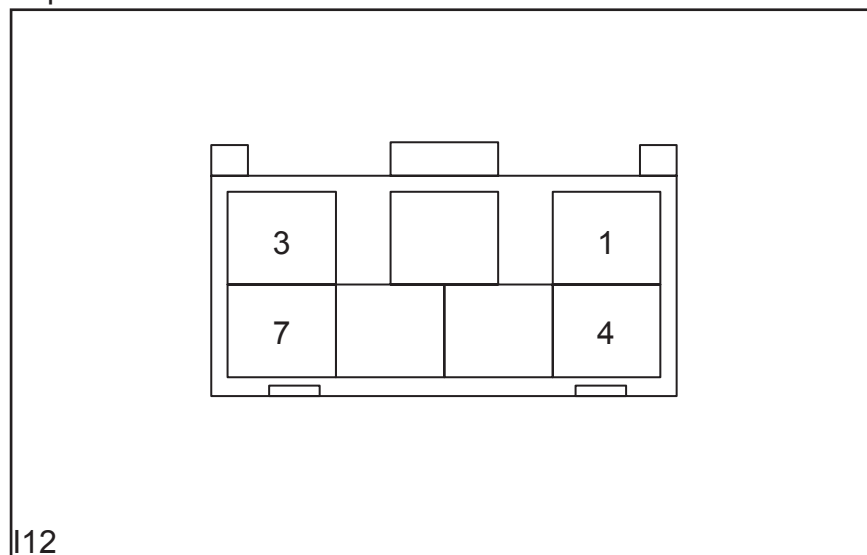

Instrument Harness Connector (I--)

I12 Pin Definition

Pin Number	Wire Width / Color	Function
1	0.50 P	Front washer Motor power
2	1.25 B	Ground
3		NC
4	0.85 Gr/W	Rear Windshield Wiper Motor power
5		NC
6		NC
7		NC

Lighting Combination Switch Connector

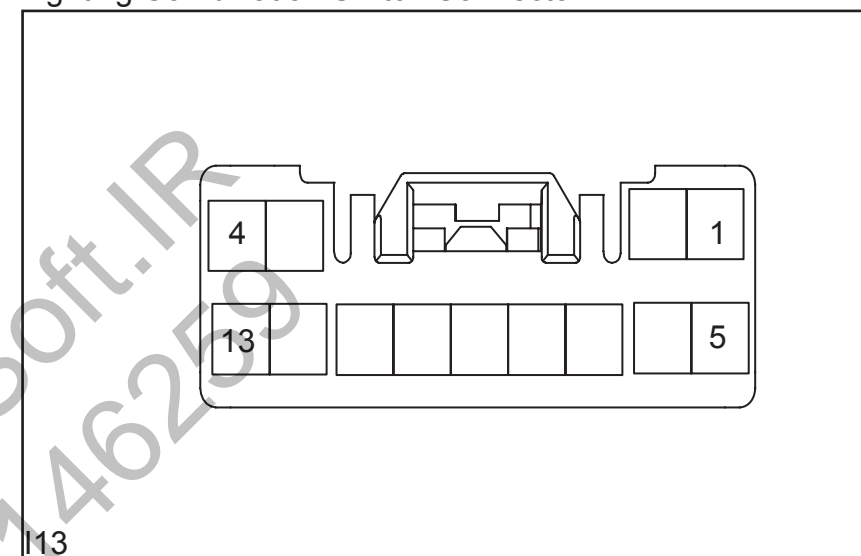

I13 Pin Definition

Pin Number	Wire Width / Color	Function
1	0.50 BI/Y	Rear fog lamp power
2		NC
3	0.50 BI/G	Fog lamp control
4		NC
5	0.50 B	Ground
6	0.50 BI/V	Low beam
7	0.50 B	Ground
8	0.50 BI/G	Width lamp
9	0.50 BI/O	High beam lamp
10		NC
11	0.50 G/BI	Turn lamp power
12	0.50 G/Y	Right turn lamp
13	0.50 G/W	Left turn lamp

Harness Connector View

Instrument Harness Connector (I--)
Hazard Warning Lamp Switch Connector

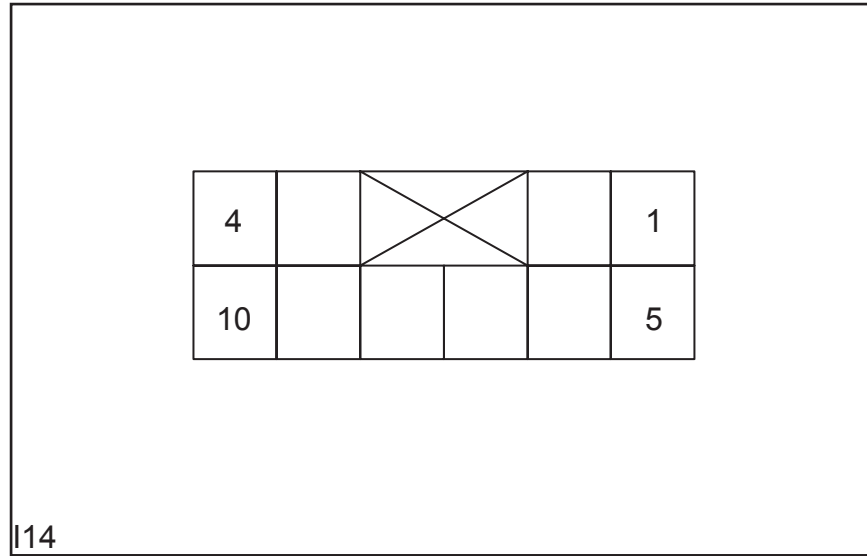

I14

I14 Pin Definition

Pin Number	Wire Width / Color	Function
1		NC
2		NC
3		NC
4	0.50 W/G	Turn lamp power
5		NC
6	0.50 B	Ground
7	0.50 Bl	Background lamp power
8		NC
9	0.85 G/B	Power
10	0.85 Gr	Hazard warning /turn lamp power

Multi-Function Screen Connector

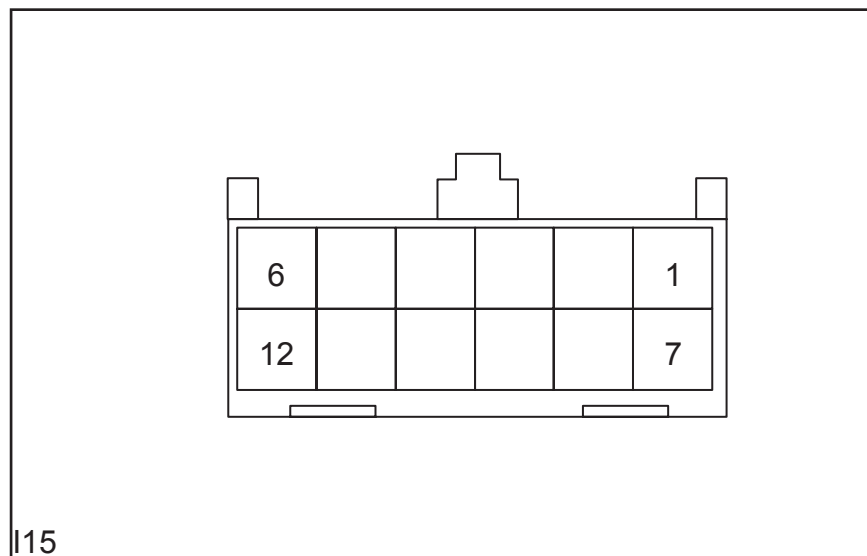

I15

Instrument Harness Connector (I--)

I15 Pin Definition

Pin Number	Wire Width / Color	Function
1	0.50 V/Y	Outside temperature sensor signal +
2	0.50 V/W	Outside temperature sensor -
3	0.50 O/G	Vehicle speed signal input
4	0.50 B	Ground
5	0.50 R/B	Power
6	0.50 R/Y	IG1 power
7	0.50 W/Br	Passenger seat belt ajar signal
8	0.50 Bl	Background lamp power
9		NC
10		NC
11		NC
12	0.50 W/G	Driver seat belt signal

Central Locking Controller Connector

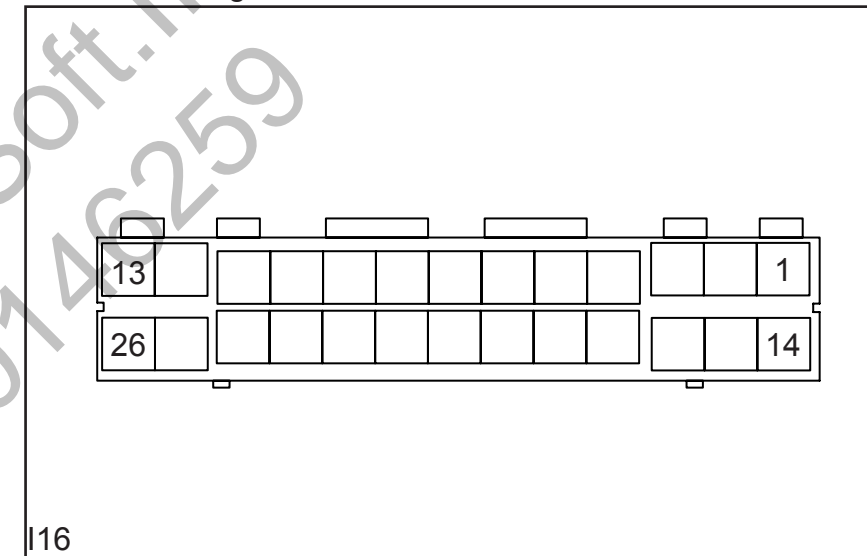

I16

Harness Connector View

Instrument Harness Connector (I--)

I16 Pin Definition

Pin Number	Wire Width / Color	Function
1	0.85 BI/W	Power
2	1.25 B/W	IG1 power output
3	0.50 Br/B	Tail gate locking unlock signal output
4		NC
5	0.50 Y	Turn right lamp power
6	0.50 W	Turn left lamp power
7	0.50 G/Y	Colision signal
8	0.50 W/B	Tail gate mcroswitch signal
9	0.50 G	RR turn lamp power
10	0.50 W	Six door ajar signal
11	0.50 W/R	LF door locking status signal
12	0.50 W/G	LR turn lamp power
13	0.50 Br	Power
14	0.50 Br/W	Unlock signal
15	0.50 Br/Y	Lock signal
16	0.50 Br	Power
17	0.50 W/BI	Diagnose signal
18	0.50 G/Y	Turn right lamp power
19	0.50 G/W	Turn left lamp power
20	0.50 W/B	Tail gate unlocking status signal
21	0.50 B/P	Trank lamp switch status signal
22	0.50 Br/Gr	Central locking lock signal
23	0.50 Br/BI	Central locking unlock signal
24	0.50 Gr/BI	Overtake 20Km/h control signal
25	0.50 B	Ground
26	0.85 Gr	Hazard warning lamp power

CD Player Connector

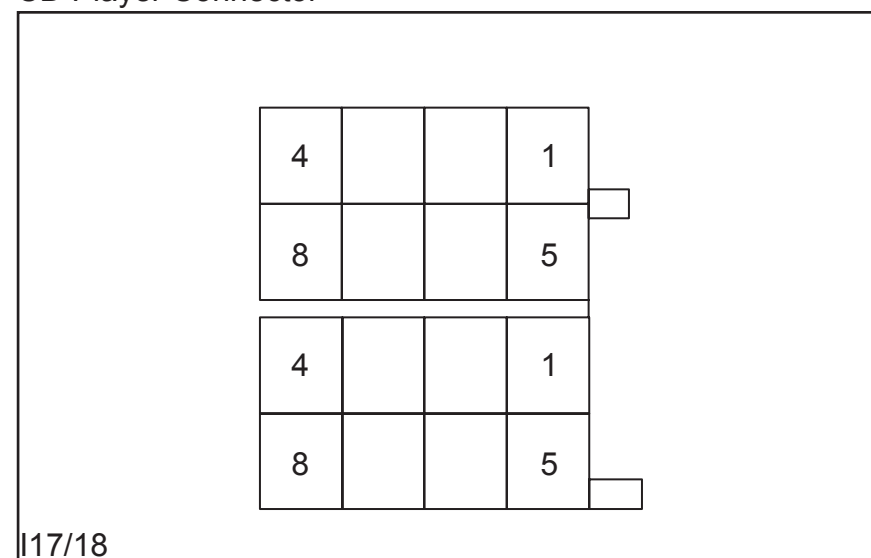

Instrument Harness Connector (I--)

I17 Pin Definition

Pin Number	Wire Width / Color	Function
1	0.50 V/Y	RR speaker +
2	0.50 V/Gr	RF speaker +
3	0.50 V/W	LF speaker +
4	0.50 V/G	LR speaker +
5	0.50 V/O	RR speaker -
6	0.50 V/Br	RF speaker -
7	0.50 V/B	LF speaker -
8	0.50 V/BI	LR speaker -

I18 Pin Definition

Pin Number	Wire Width / Color	Function
1	0.50 W	CD system control
2	0.50 V/Y	Speaker sounding enable
3	0.50 V/Br	Speaker sounding control
4	0.85 V/R	Battery power
5	0.50 G/P	Reverse lamp switch signal
6	0.85 V	ACC power
7	0.50 BI	Background lamp power
8	0.85 B	Ground

Brake Lamp Switch Connector

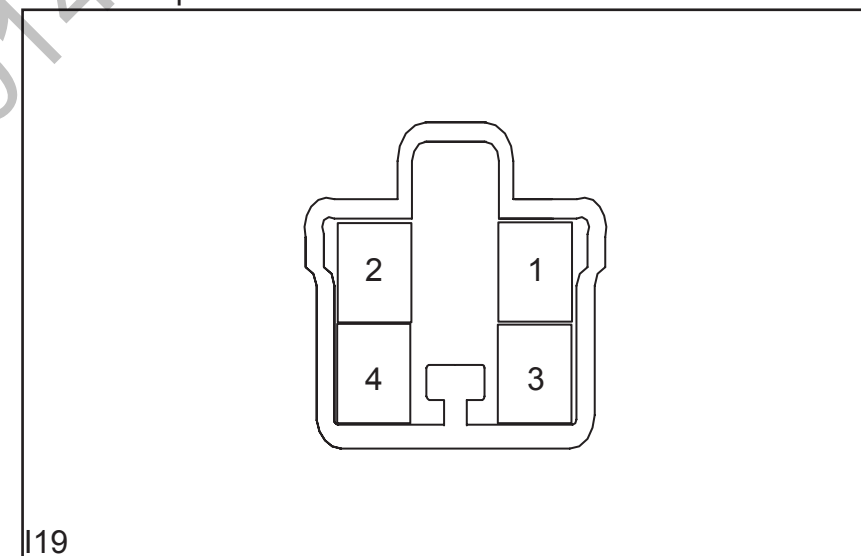

I19 Pin Definition

Pin Number	Wire Width / Color	Function
1	0.85 G/B	Power
2	0.50 G/Gr	Brake lmap switch signal
3	0.50 G/BI	Power
4	0.50 G/W	Brake switch signal

Harness Connector View

Instrument Harness Connector (I--)

Clutch Switch(MT Vehicle) Connector

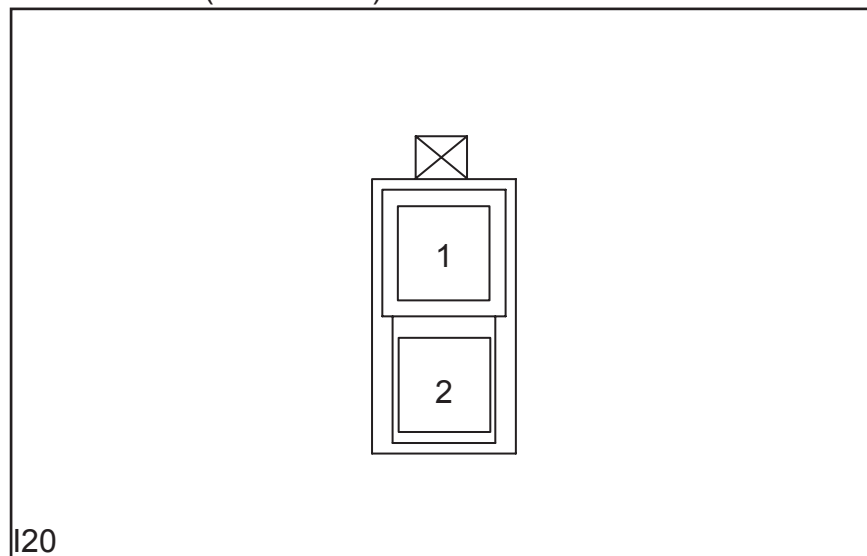

I20

I20 Pin Definition

Pin Number	Wire Width / Color	Function
1	0.50 B	Ground
2	0.50 B/W	Clutch switch +

Shift Gear Switch(CVT) Connector

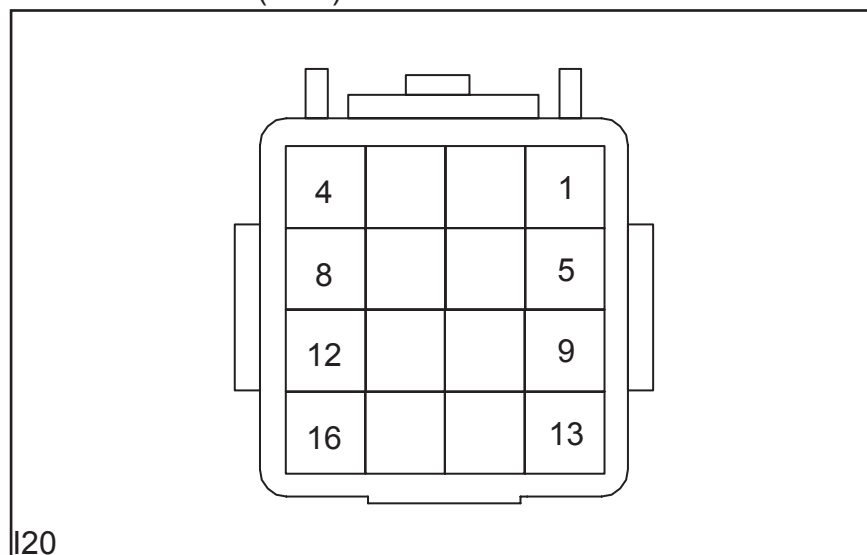

I20

I20 Pin Definition

Pin Number	Wire Width / Color	Function
1	0.50 G	Shift switch signal
2	0.50 W/G	Reduce speed signal
3	0.85 B	Ground
4	0.50 BI	Background lmap power
5	0.50 BI	Background lmap power
6	0.85 B	Ground
7	0.50 BI/W	Shift control lock
8	0.50 Y	Shift switch signal

Instrument Harness Connector (I--)

Pin Number	Wire Width / Color	Function
9		NC
10	0.85 B	Ground
11	0.50 Y/W	E/D model
12	0.50 B	Ground
13		NC
14		NC
15		NC
16		NC

Clock Spring Connector

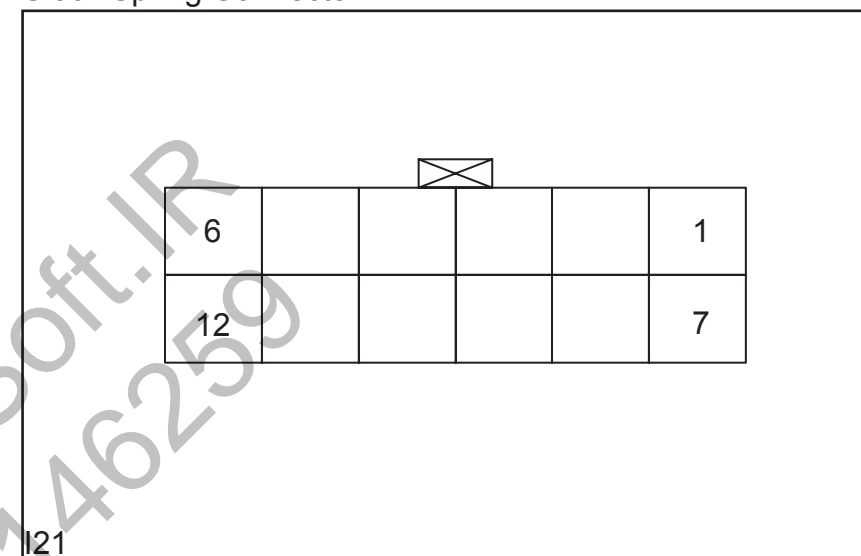

I21

I21 Pin Definition

Pin Number	Wire Width / Color	Function
1		N/C
2		NC
3		NC
4		NC
5		NC
6		NC
7		NC
8	0.50 W	CD system control
9	0.50 B	Ground
10	0.50 BI	Background lamp power
11	0.50 P/W	Horn power
12		NC

Harness Connector View

Instrument Harness Connector (I--)

Diagnose Interface Connector

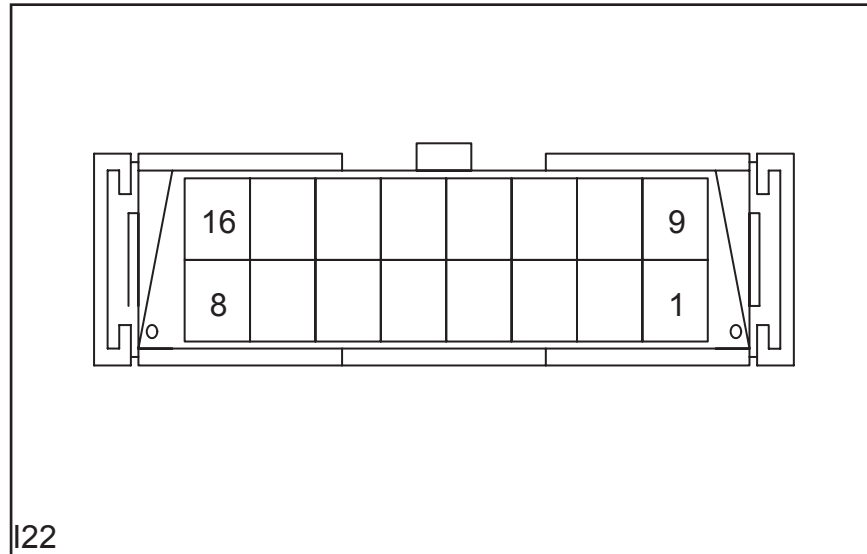

I22

I22 Pin Definition

Pin Number	Wire Width / Color	Function
1		NC
2		NC
3		NC
4	0.50 B	Ground
5	0.50 B	Ground(PEPS)
6	0.50 W	CAN-L
6	0.50 W/BI	CAN-H(PEPS)
7	0.50 P/G	K-line
8	0.50 R/Y	IG1 Power
9	0.50 W/G	CVT/EPS Diagnose
10		NC
11		NC
12	0.50 W/R	SRS Diagnose
13	0.50 W/BI	Diagnose signal
14	0.50 W/B	CAN-L(PEPS)
14	0.50 W/B	CAN-H
15		NC
16	0.50 R/B	Power 12V

Instrument Harness Connector (I--)

IMMO Coil Connector

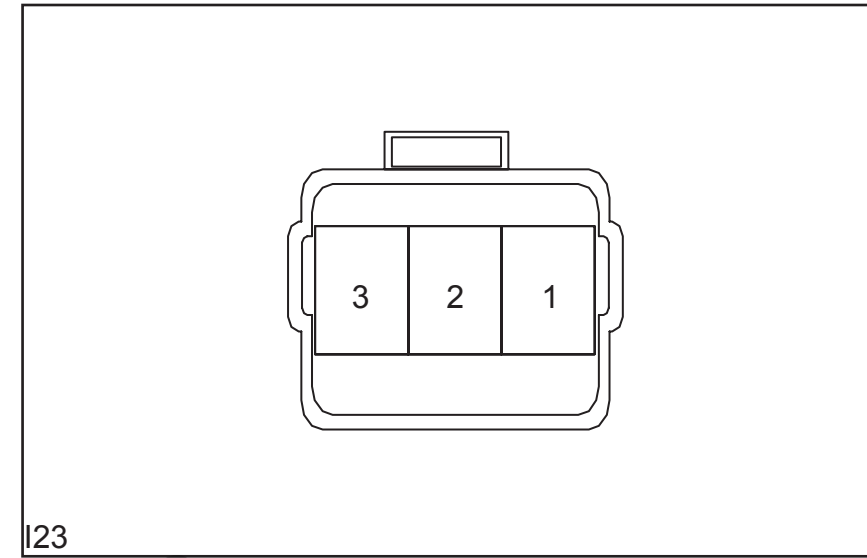

I23

I23 Pin Definition

Pin Number	Wire Width / Color	Function
1	0.50 Br/Y	Key recognition signal
2		NC
3	0.50 Br/W	Key recognition signal

Intelligent Breaker Connector

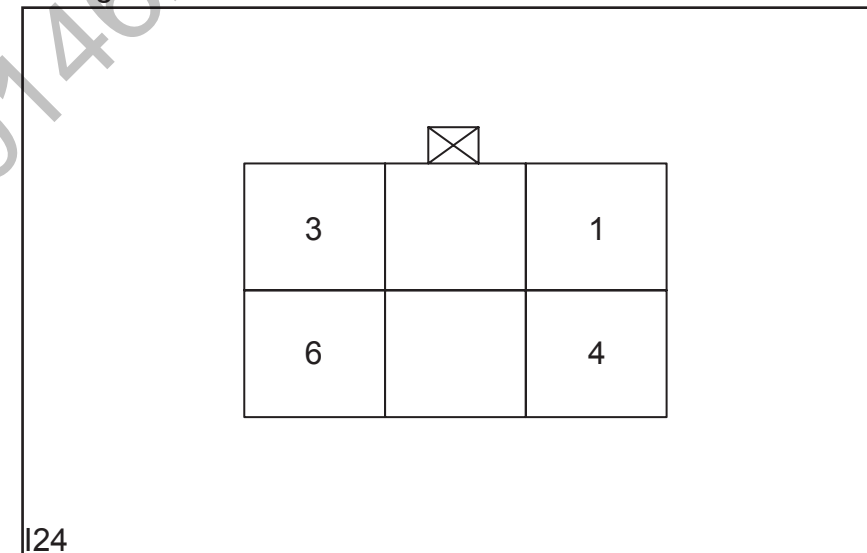

I24

I24 Pin Definition

Pin Number	Wire Width / Color	Function
1		NC
2	2.00 R/B	Battery power
3	0.50 G/BI	Power
4	2.00 R	Battery Power
5		NC
6	0.50 B	Ground

Harness Connector View

Instrument Harness Connector (I--)

Central Control Box-1 Connector

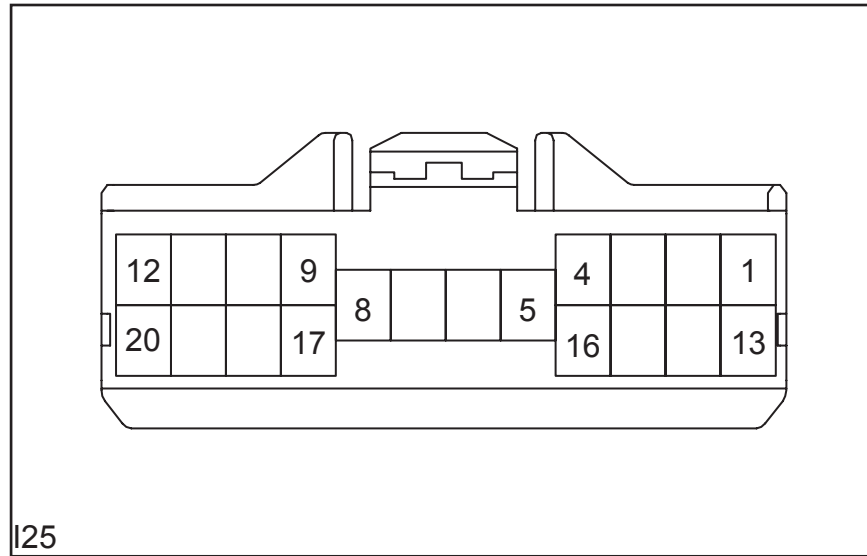

I25

I25 Pin Definition

Pin Number	Wire Width / Color	Function
1		NC
2	0.50 R/B	ABS ECU power
3	0.50 Y/W	TCM power
4	1.25 BI/W	Alternater/IMMO/center lock control unit power
5	1.25 R	Seat heating power
6	0.50 B/W	Start motor control
6	0.50 Br	Start motor control(PEPS)
7	2.00 B/Y	Start power
8	2.00 R/BI	Start power
9		NC
10		NC
11		NC
12		NC
13		NC
14	0.50 G/BI	Turn/Daytime running/reverse lamp power
15	0.85 B	Reverse lamp control
16	0.50 G/P	Reverse lamp power
17	0.50 Br/Y	Reverse lamp control(CVT)
18	0.50 Y/R	SRS power
19	0.50 Y	EPS power
20	0.50 R/Y	Instrument power

Instrument Harness Connector (I--)

Central Control Box-2 Connector

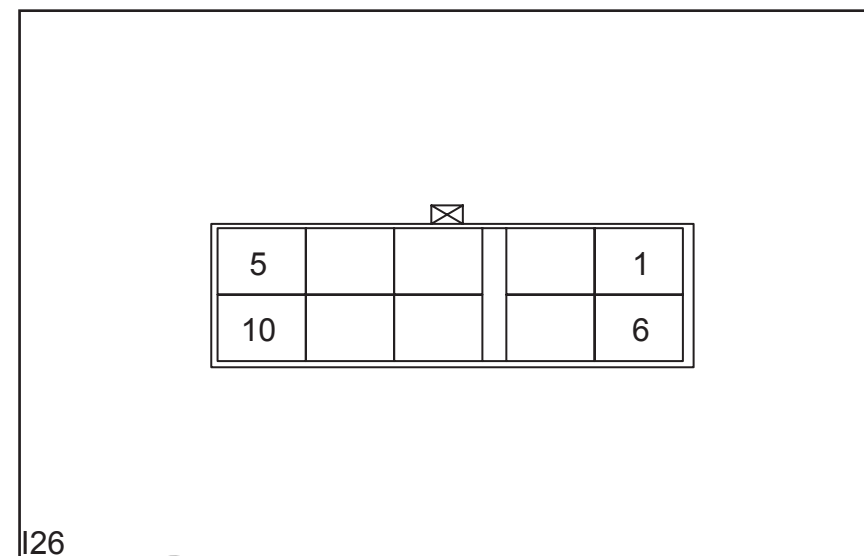

I26

I26 Pin Definition

Pin Number	Wire Width / Color	Function
1	0.85 Gr	Washer/wiper Switch Power
2	2.00 R	Battery power
3	3.00 R/W	Battery power
4	0.50 BI/Y	Rear fog lmap control
5	0.50 G/Br	Rear fog lmap power
6	0.50 BI	Background lmap power
7	0.50 BI/G	Background lmap control
8	0.50 Y	Sunroof Power
9	2.00 P	Defrost heating power
10	0.50 Gr/R	Defrost heating control

Harness Connector View

Instrument Harness Connector (I--)

Central Control Box-3 Connector

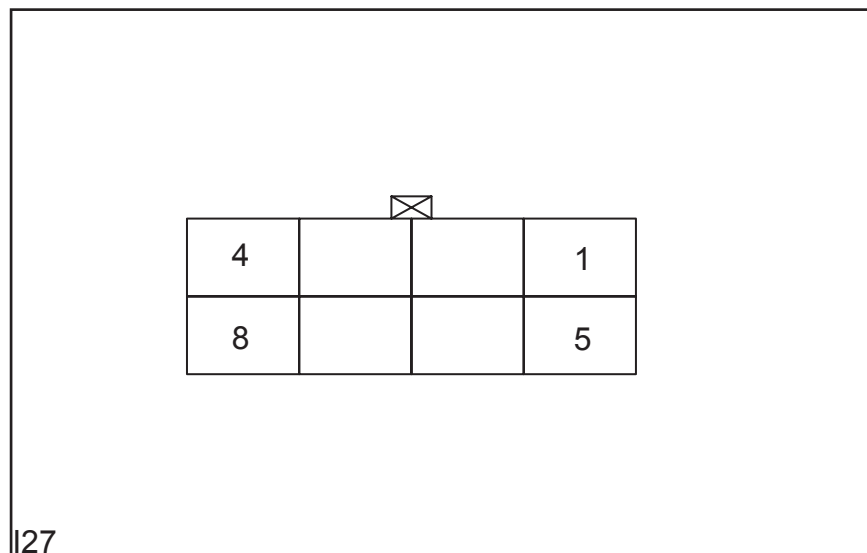

I27

I27 Pin Definition

Pin Number	Wire Width / Color	Function
1	0.50 B	Ground
2		NC
3	3.00 Gr/Bl	Blower power
4		NC
5	2.00 Y	Power window power
6		NC
7		NC
8		NC

Central Control Box-4 Connector

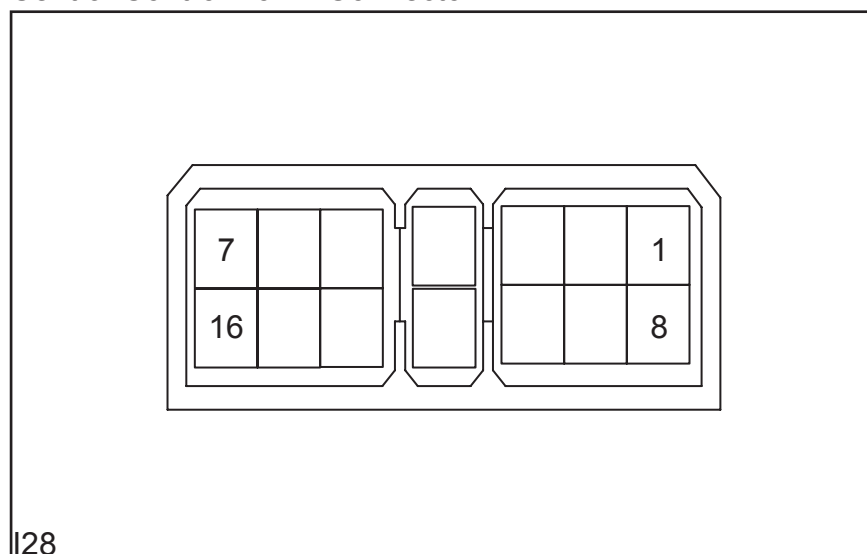

I28

I28 Pin Definition

Pin Number	Wire Width / Color	Function
1		NC
2	0.85 B	Blower relay ground
3	0.50 V	CD power
4		NC

Instrument Harness Connector (I--)

Pin Number	Wire Width / Color	Function
5	0.85 O/B	power control
6	0.85 Bl/R	power
7	0.85 R	Alternater power
8	1.25 V/Y	Power
9	0.50 Gr	Power rearview power
10	0.50 Y/P	ACC power
11		NC
12	0.50 Gr	A/C control padel power
13		NC
14	0.50 G/B	Hazard warning/brake lamp power

Central Control Box-5 Connector

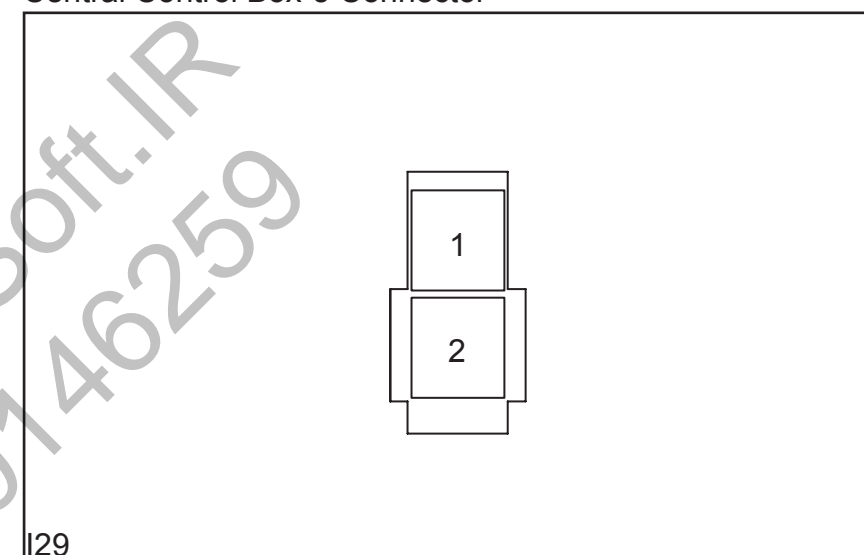

I29

I29 Pin Definition

Pin Number	Wire Width / Color	Function
1	3.00 R/G	IG2 power
2	3.00 R/B	ACC power

Harness Connector View

Instrument Harness Connector (I--)

Central Control Box-6 Connector

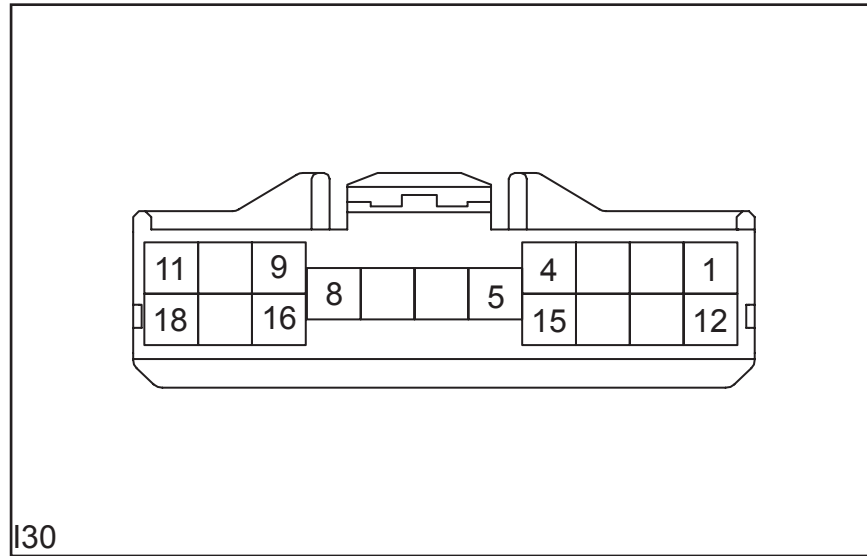

I30

I30 Pin Definition

Pin Number	Wire Width / Color	Function
1	0.50 R/B	Instrument cluster power
2		NC
3		NC
4		NC
5	0.50 G/V	Dome light power
6	0.85 V/R	CD power
7	2.00 R	Battery power
8	2.00 R/Y	IG1 power
9		NC
10		NC
11		NC
12	0.50 Br	Center lock/IMMO power
13		NC
14		NC
15		NC
16		NC
17		NC
18		NC

Instrument Harness Connector (I--)

EPS ECU Connector

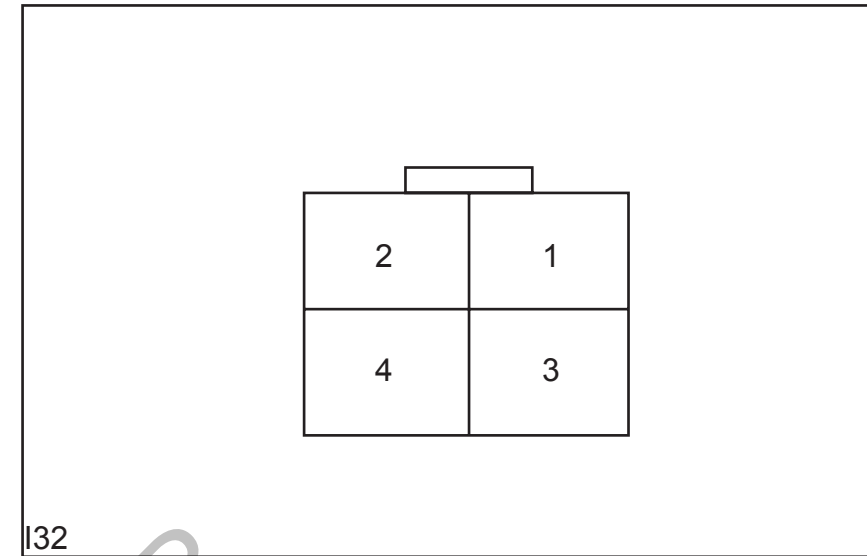

I32

I32 Pin Definition

Pin Number	Wire Width / Color	Function
1		NC
2		NC
3	3.00 R	Power
4	3.00 B	Ground

Harness Connector View

Instrument Harness Connector (I--)

EPS ECU Connector

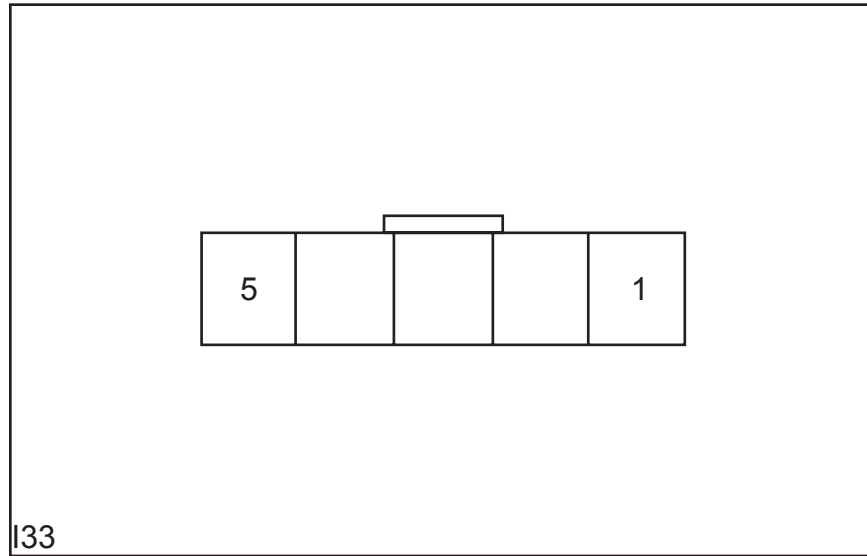

I33

I33 Pin Definition

Pin Number	Wire Width / Color	Function
1	3.00 R	Power
2		NC
3	3.00 B	Ground
4	0.50 G	Signal
5	0.50 Y	Signal

EPS Motor Connector

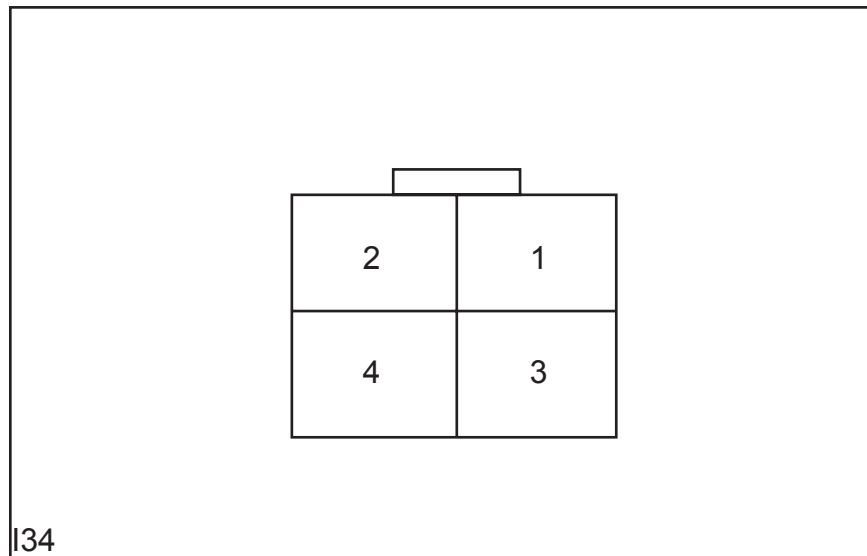

I34

I34 Pin Definition

Pin Number	Wire Width / Color	Function
1		NC
2		NC
3	3.00 R	Power
4	3.00 B	Ground

Instrument Harness Connector (I--)

EPS Torque Sensor Connector

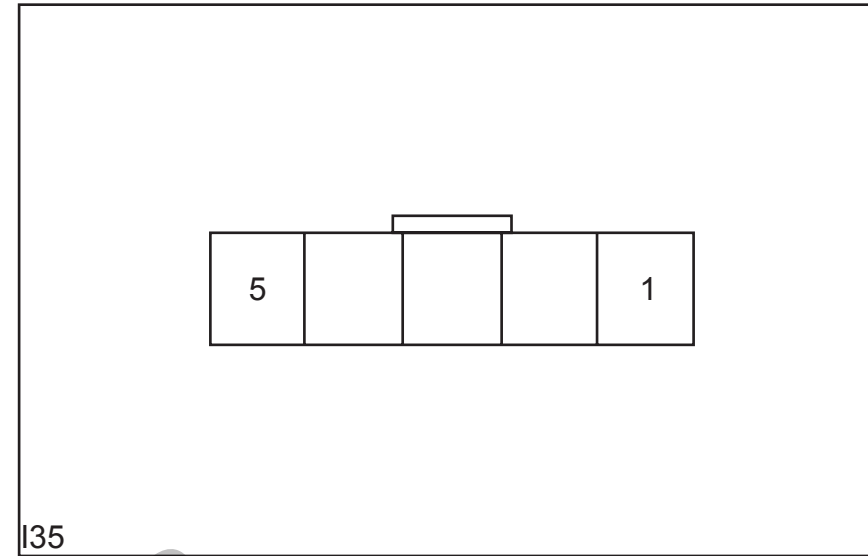

I35

I35 Pin Definition

Pin Number	Wire Width / Color	Function
1	3.00 R	Power
2		NC
3	3.00 B	Ground
4	0.50 G	Signal
5	0.50 Y	Signal

Steering Angle Sensor Connector

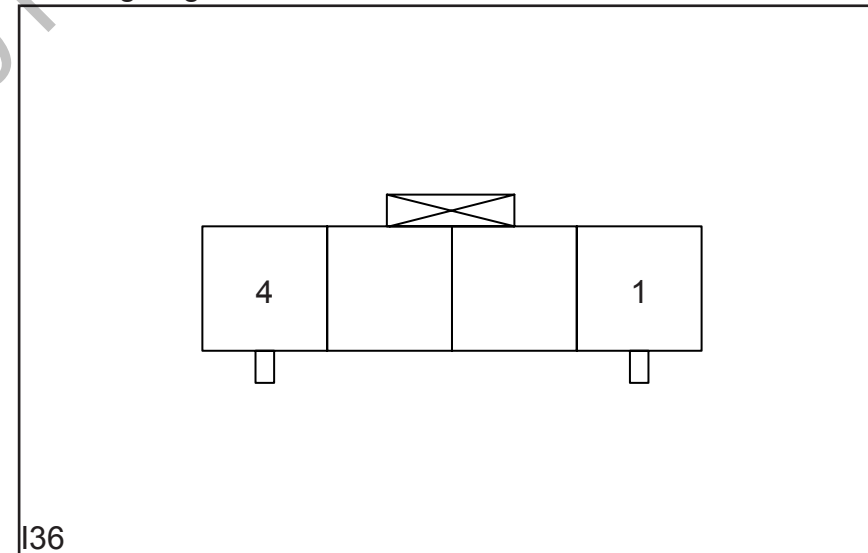

I36

I36 Pin Definition

Pin Number	Wire Width / Color	Function
1	0.50 B	Ground
2	0.50 R/B	IG1 power
3	0.50 W/BI	CAN-H/signal
4	0.50 W/B	CAN-L/signal

Harness Connector View

Instrument Harness Connector (I--)

PEPS Controller A Connector

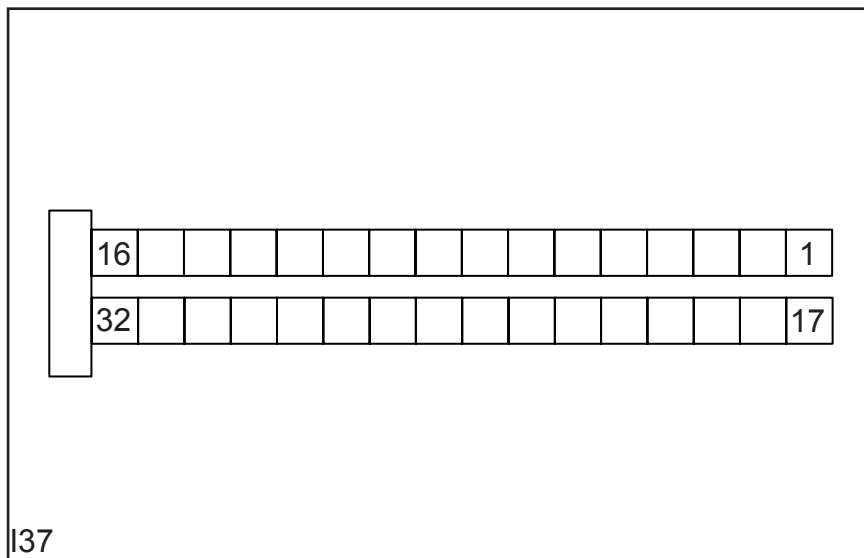

I37 Pin Definition

Pin Number	Wire Width / Color	Function
1	0.50 G/Y	Turn right input
2	0.50 G/W	Turn left input
3	0.85 Gr	Hazard warning lamp input
4		NC
5	0.50 W/B	Engine speed output signal
6	0.50 B/Y	Starter relay feedback signal
7	0.50 R/G	Battery power
8	0.50 R/Y	IG1 power
9	0.50 R/B	Battery power
10	0.50 Br/R	ACC signal
11	0.50 Br	Starter relay control signal
12	0.50 W/Br	Button Start Switch power
13		NC
14	0.50 Br	LF door lock status switch signal
15		NC
16		NC
17	0.50 Br/W	K-line
18	0.50 B/W	Clutch switch signal
19		NC
20		NC
21	0.50 B/W	P/N gear switch signal
22		NC
23	0.50 W/BI	CAN-H
24	0.50 W/B	CAN-L
25	0.50 Br/Y	Power
26	0.50 W	PEPS fault indicator
27	0.50 B/W	ESCL fault indicator
28	0.50 Br/Gr	Power
29	0.50 Br/BI	Power

Instrument Harness Connector (I--)

PEPS Controller B Connector

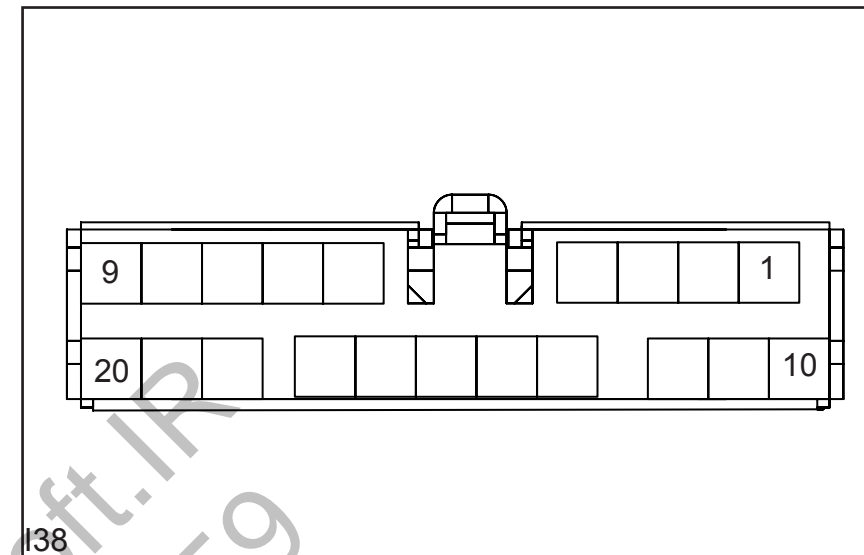

I38 Pin Definition

Pin Number	Wire Width / Color	Function
1	0.50 W/G	Turn left output
2	0.50 G	Turn right output
3	0.50 W	Turn left output
4	0.50 Y	Turn right output
5	0.85 G/B	Power 12V
6	0.50 Br/W	Unlock Signal
7	0.50 Br/Y	Lock Signal
8	0.50 B	Ground
9	2.00 R/G	Power 12V
10	1.25 R	Power 12V
11	0.50 Br/P	ESCL power
12	0.50 Br/V	ESCL signal input
13	0.50 Br/O	Ground
14	0.50 Br	IMMO fault indicator
15		NC
16	1.25 BI/W	IG1 power
17	0.50 Br/B	Unlock power output
18	0.50 P/W	Horn control signal input
19	0.50 B	Ground
20	2.00 R/G	Power 12V

Harness Connector View

Instrument Harness Connector (I--)

PEPS Controller C Connector

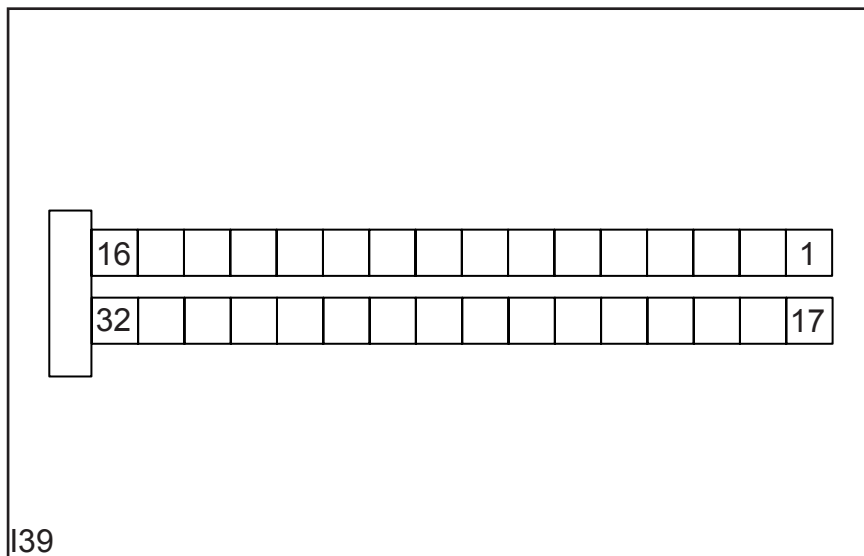

I39

I39 Pin Definition

Pin Number	Wire Width / Color	Function
1	0.50 B/Br	Antenna signal -
2	0.50 Br/R	Antenna signal +
3	0.50 Br/W	Antenna signal -
4	0.50 V/Br	Antenna signal +
5		NC
6	0.50 O/B	Antenna signal -
7	0.50 Bl/Br	Antenna signal +
8	0.50 Br/O	Antenna signal +
9		NC
10		NC
11		NC
12		NC
13	0.50 G/Gr	NC
14	0.50 Br/V	Button Start Switch signal
15	0.50 Br/O	Button Start Switch signal
16	0.50 G/Y	SRS colision signal
17		NC
18	0.50 P/Br	Antenna signal +
19	0.50 Br/B	Antenna signal -
20	0.50 Br/P	Antenna signal -
21	0.50 B/P	Tail gate ajar signal input
22	0.50 Gr/B	Four door ajar signal input
23		NC
24	0.50 W/B	Status signal
25	0.50 Br/Y	LF door switch signal
26	0.50 Br/G	LF door switch signal
27	0.50 W/Bl	Vehicle speed sensor input
28	0.50 Br/P	LED Background lamp signal
29	0.50 R/Br	LED Background lamp signal

Instrument Harness Connector (I--)

Pin Number	Wire Width / Color	Function
30	0.50 G/Br	LED Background lamp signal
31	0.50 Br/Gr	lock Signal
32	0.50 Br/Bl	Unlock Signal

GPS-1 Connector

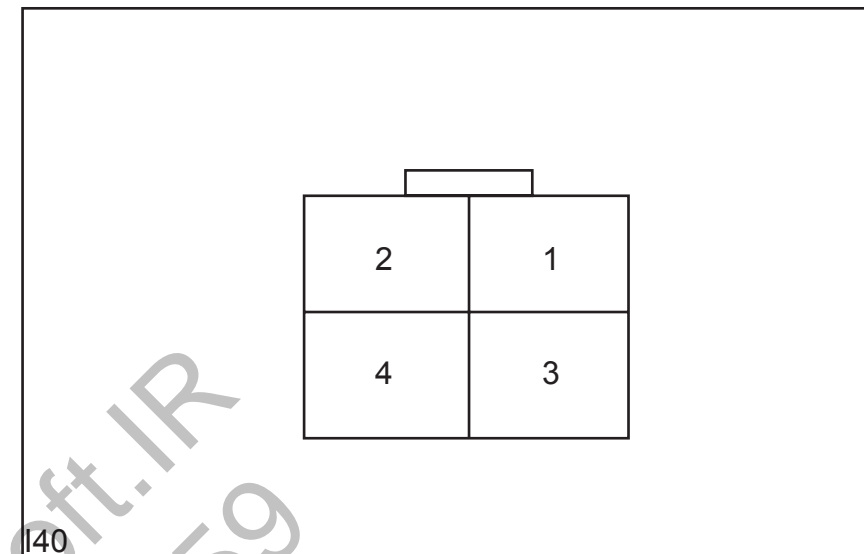

I40

I40 Pin Definition

Pin Number	Wire Width / Color	Function
1	0.50 B	signal -
2	0.50 W	signal +
3	0.50 G	Power -
4	0.50 R	signal +

GPS-2 Connector

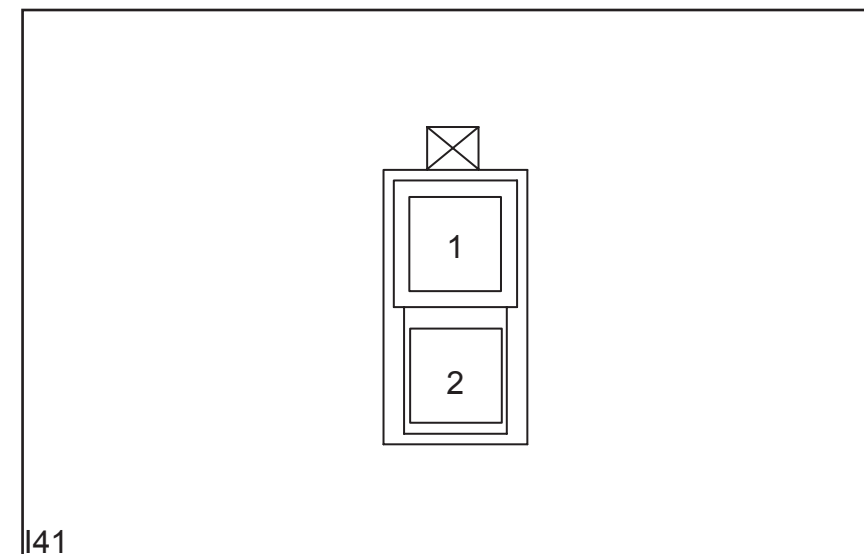

I41

I41 Pin Definition

Pin Number	Wire Width / Color	Function
1		NC
2	0.50 G/P	signal

Harness Connector View

Instrument Harness Connector (I--)

Antenna-1 Connector

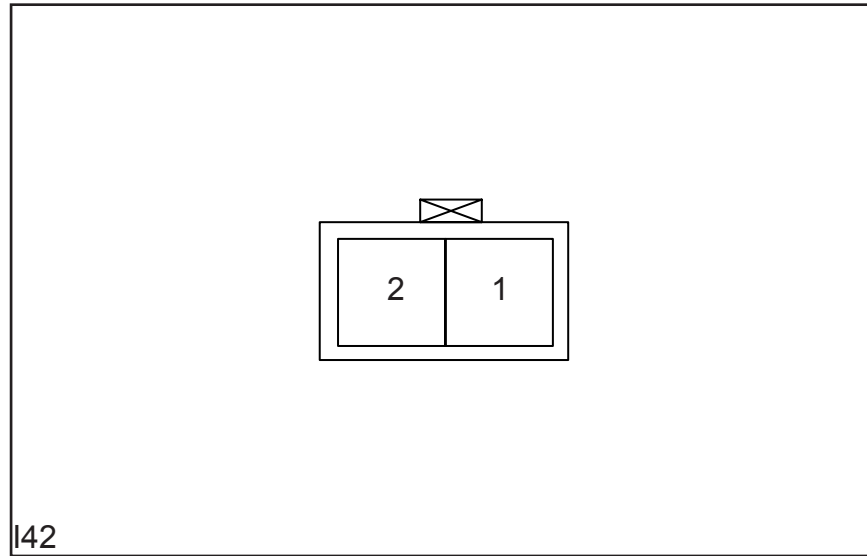

I42

I42 Pin Definition

Pin Number	Wire Width / Color	Function
1	0.50 Br/O	Signal +
2	0.50 Br/P	Signal -

ESCL Connector

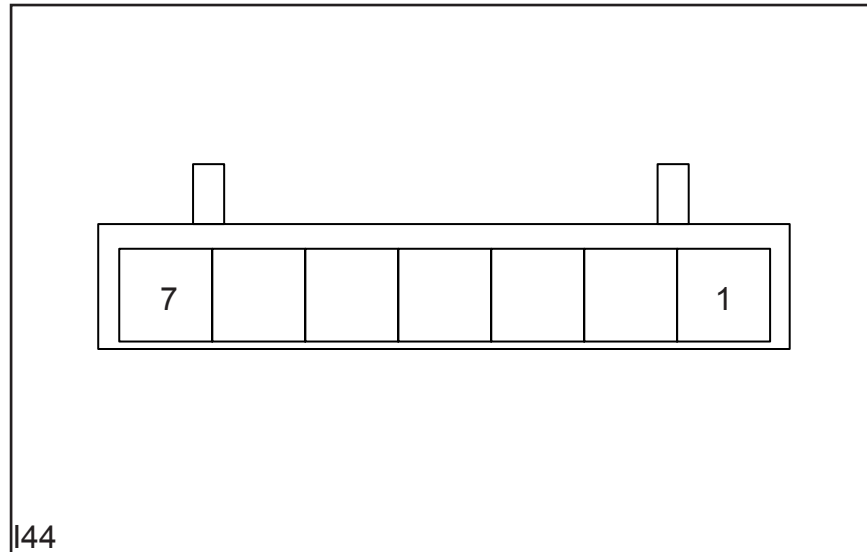

I44

I44 Pin Definition

Pin Number	Wire Width / Color	Function
1	0.50 Br/P	ESCL power
2	0.50 Br/W	K-lin
3	0.50 Br/R	ACC signal
4		NC
5		NC
6	0.50 Br/O	Ground
7	0.50 Br/V	ESCL signal input

Instrument Harness Connector (I--)

Button Switch Connector

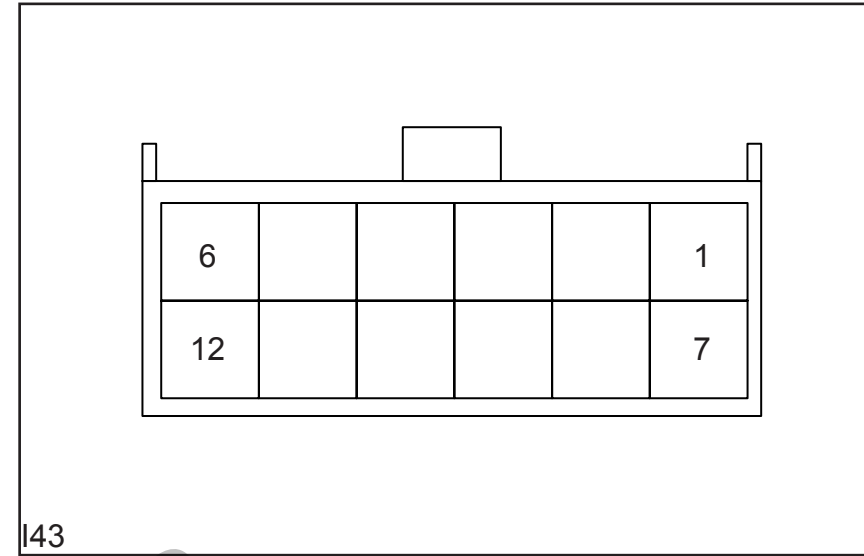

I43

I43 Pin Definition

Pin Number	Wire Width / Color	Function
1	0.50 R/Br	LED Background lamp signal
2	0.50 Br/V	Button Start Switch signal
3	0.50 W/Br	Button Start Switch power
4		NC
5	0.50 Br/P	LED Background lamp signal
6	0.50 BI	IMMO Antenna -
7	0.50 O/B	IMMO Antenna +
8	0.50 Br/O	Button Start Switch signal
9		NC
10		NC
11	0.50 G/Br	LED Background lamp signal
12		NC

Harness Connector View

Instrument Harness Connector (I--)

TPMS Connector

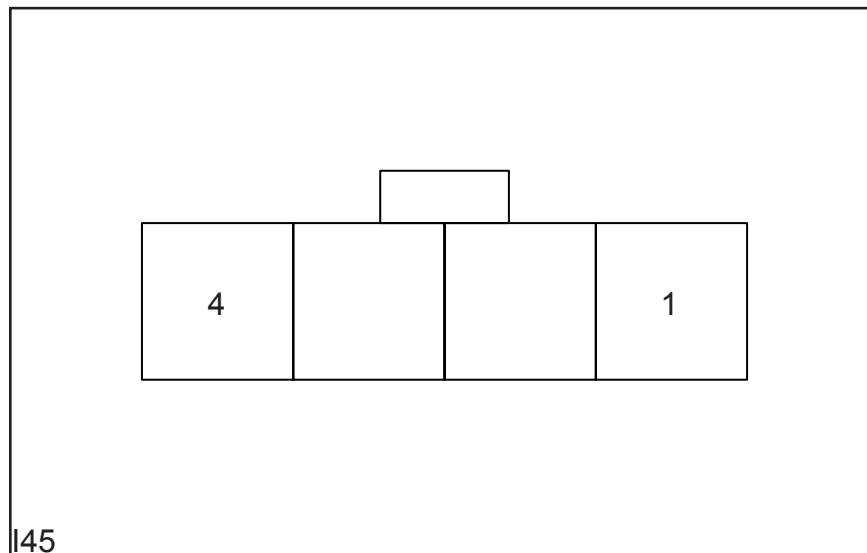

I45

I45 Pin Definition

Pin Number	Wire Width / Color	Function
1	0.50 B	Power
2		NC
3	0.50 Y	Ground
4		NC

IP Harness to Roof Harness Connector

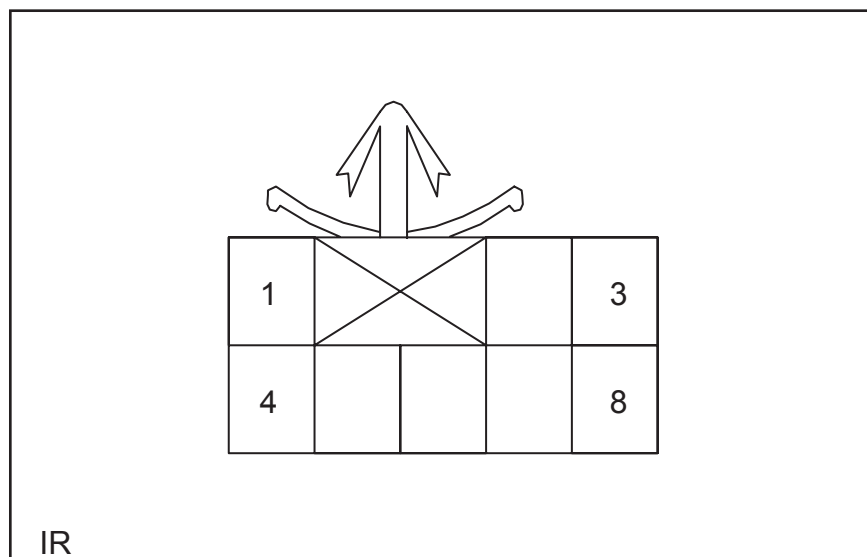

IR

IR Pin Definition

Pin Number	Wire Width / Color	Function
1	0.50 G/V	Power
2	0.50 Gr/B	Instrument Cluster singal
3	0.50 Y	Power
4	2.00 R	Power
5	2.00 B	Ground
6	0.50 B	Ground
7		N/C
8		N/C

Instrument Harness Connector (I--)

IP Harness to A/C Harness Connector

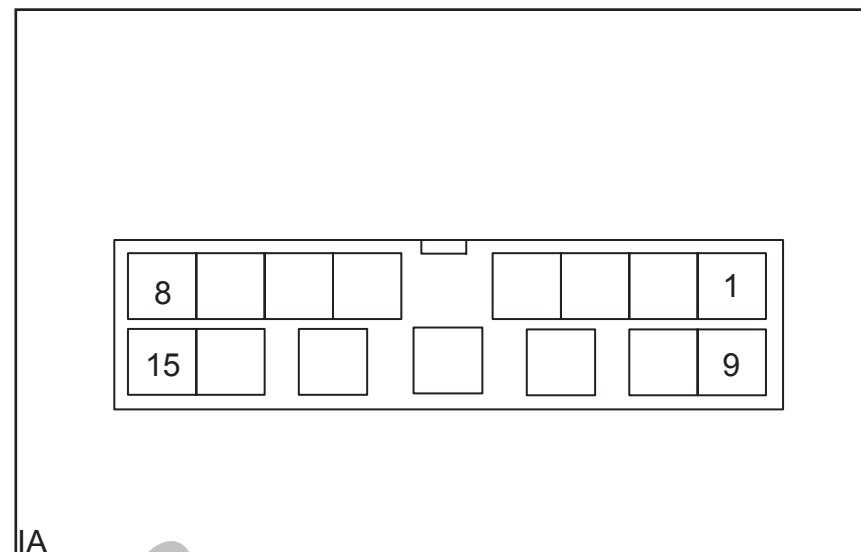

IA

IA Pin Definition

Pin Number	Wire Width / Color	Function
1	0.85 Gr	IG2 power
2	0.50 BI	Background lamp power
3	0.85 Gr/R	Defrosting control
4		NC
5	0.85 B	Signal ground
6	0.85 Gr/Y	A/C control
7		NC
8		NC
9		NC
10		NC
11	3.00 Gr/BI	Blower power
12	3.00 B	Regulator module ground
13		NC
14		NC
15		NC

Harness Connector View

Instrument Harness Connector (I--)

IP Harness to LF Door Harness Connector

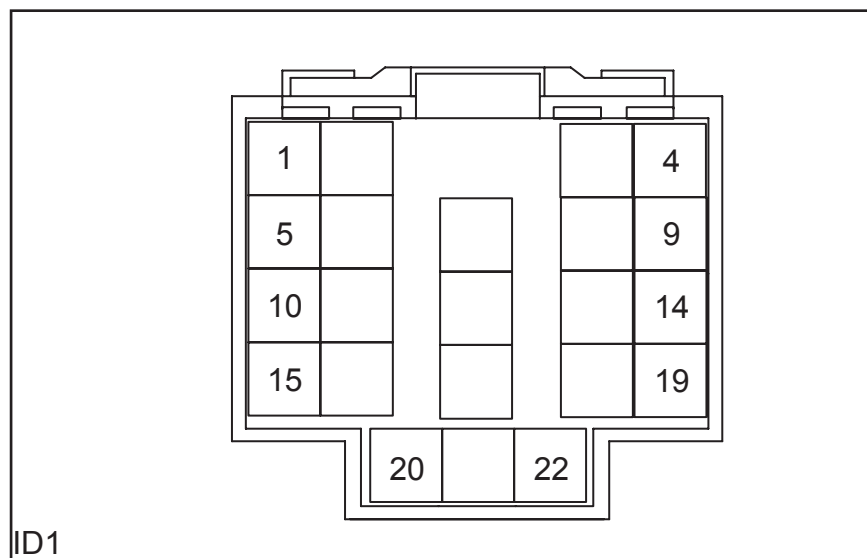

ID1

ID1 Pin Definition

Pin Number	Wire Width / Color	Function
1	0.50 V/W	LF door speaker +
2	0.50 V/B	LF door speaker -
3	0.50 P	Left outside rearview heating power
4	0.50 B	Ground
5	0.50 Y/Br	Left outside rearview left/right power
6	0.50 Y/G	Left outside rearview up/down power
7	2.00 B	Ground
8	0.50 Y/W	Left outside rearview up/down or left/right adjustment
9	1.25 Y/Bl	RF door power window up power
10	1.25 Y/G	RF door power window down power
11	1.25 Y/Br	LR door power window up
12	2.00 Y	LF door power window switch power
13	1.25 Y/V	LR door power window down
14	1.25 Y/O	RR door power window up signal
15	1.25 Y/P	RR door power window down signal
16	0.50 W/G	Left side turn lamp power
17	1.25 Y/R	RR power window switch power
18	0.50 Br	LF door lock status switch signal
19	0.50 Br/Y	Lock signal
20	0.50 Br/W	Unlock signal
21		NC
22		NC

Instrument Harness Connector (I--)

IP Harness to LF Door Harness Connector

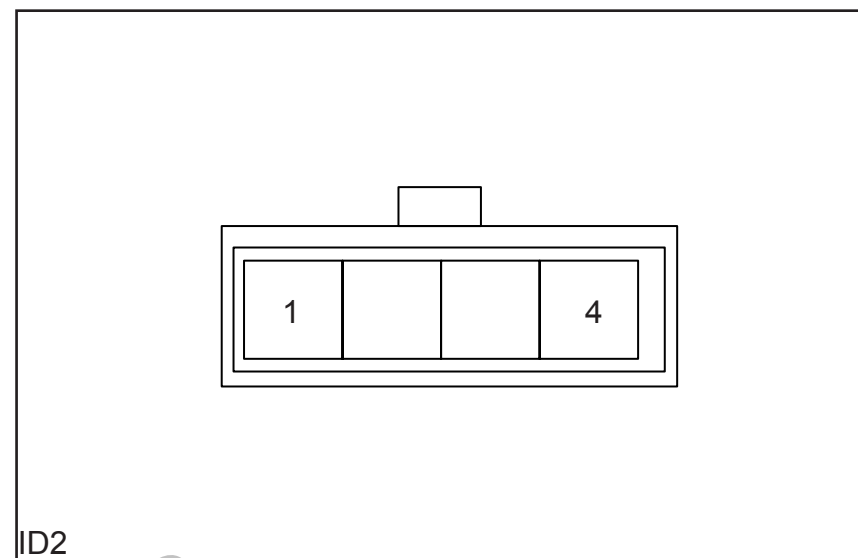

ID2

ID2 Pin Definition

Pin Number	Wire Width / Color	Function
1	0.50 Br/R	LF door antenna signal +
2	0.50 Br/W	LF door antenna signal -
3	0.50 Br/Y	LF door Locking signal
4	0.50 Br/G	LF door Locking signal

Harness Connector View

Instrument Harness Connector (I--)

IP Harness to RF Door Harness Connector

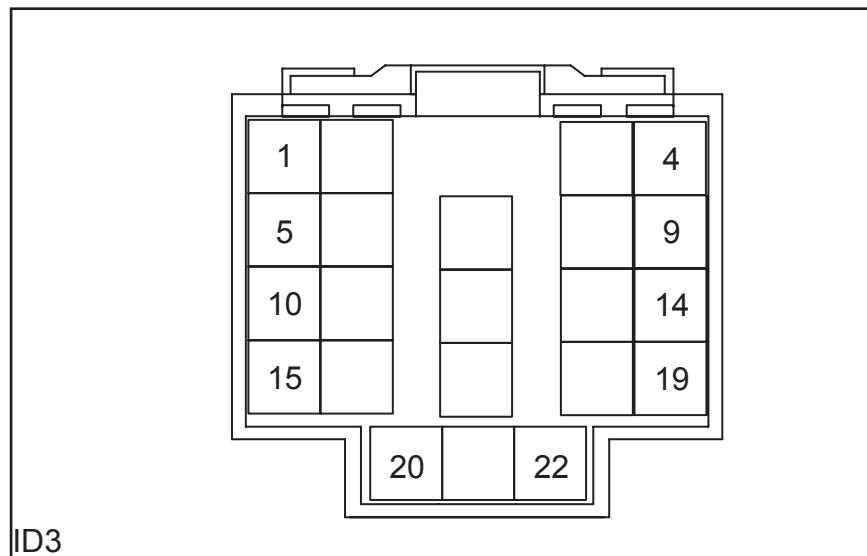

ID3

ID3 Pin Definition

Pin Number	Wire Width / Color	Function
1	0.50 V/Br	RF speaker -
2	0.50 V/Gr	RF speaker +
3	0.50 P	Right outside rearview heating power
4	0.50 B	Ground
5	0.50 G	Right side turn lamp +
6	0.50 Y/BI	Right outside rearview up/down power
7	1.25 Y/R	RF door power window switch up signal
8	0.50 Y/W	Right outside rearview up/down or left/right adjustment
9	0.50 Br/W	Unlock signal
10	0.50 Br/Y	Lock signal
11	0.50 Y/Gr	Right outside rearview left/right power
12	1.25 Y/G	RF door power window down
13		NC
14		NC
15		NC
16		NC
17	1.25 Y/BI	RF door power window up signal
18		NC
19		NC
20		NC
21		NC
22		NC

Instrument Harness Connector (I--)

IP Harness to Engine Compartment Harness Connector

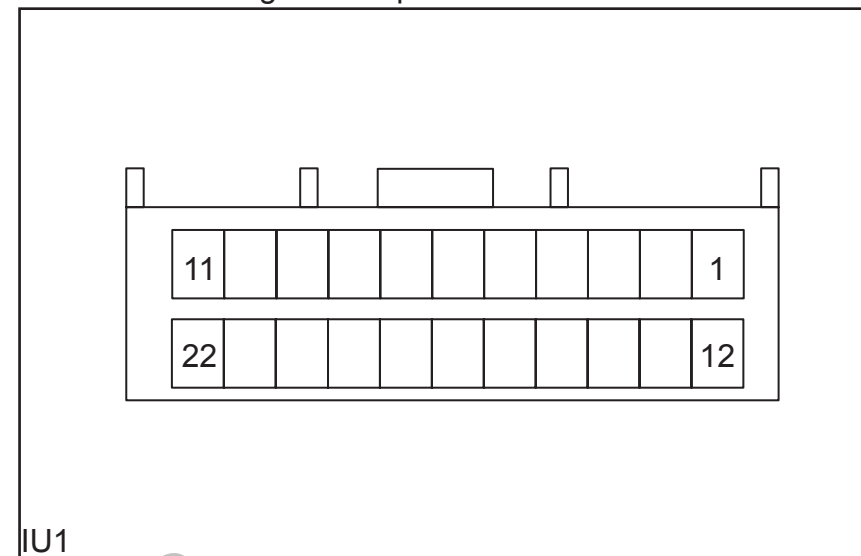

IU1

IU1 Pin Definition

Pin Number	Wire Width / Color	Function
1	0.85 V/W	Outside temperature sensor -
2	0.85 V/Y	Outside temperature sensor signal
3	0.85 P/Y	Engine compartment release signal
4	0.50 W/BI	Vehicle speed signal
5	0.85 P/B	Brake fluid level signal
6	0.50 BI/V	Low beam headlamp relay control
7	0.50 BI/O	High beam headlamp relay control
8		NC
9	0.50 P/W	Horn switch
10	0.50 G/Gr	Brake signal
11	0.50 BI/Y	Adjust motor power
12	0.50 P/G	K-line
13	0.50 Br/P	RR wheel speed sensor signal +
14	0.50 Br/G	RR wheel speed sensor signal -
15	0.50 Br/Gr	LR wheel speed sensor signal +
16	0.50 Br/BI	LR wheel speed sensor signal -
17	0.50 W/G	Brake system fault indicator
18	0.50 W	ABS fault indicator
19	0.85 Y/BI	LF colision sensor -
20	0.85 Y/Br	LF colision sensor +
21	0.85 Y/Gr	RF colision sensor -
22	0.50 Y/V	RF colision sensor +

Harness Connector View

Instrument Harness Connector (I--)

IP Harness to Engine Compartment Harness(MT) Connector

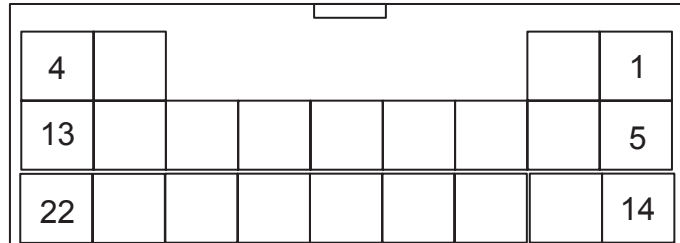

IU2

IU2 Pin Definition

Pin Number	Wire Width / Color	Function
1	0.85 Gr	Wiper/washer motor power
2	1.25 Gr/B	Wiper high speed of wiper +
3	0.85 Gr/Y	Wiper low speed of wiper +
4	0.85 Gr/R	Wiper return
5	1.25 R/W	Fuel pump power
6	0.50 G/BI	Rear washer motor power
7	0.85 BI/W	High beam indicator lamp
8	0.50 BI/Y	Low beam indicator lamp
9	0.50 BI	Width lamp power
10	0.50 G/BI	LF daytime running lamp +
11	0.50 P	Washer motor
12	0.85 B	Ground
13	0.85 B	Ground
14	0.50 R/B	ABS ECU IG1 power
15	0.50 W	LF turn lamp +
16	0.50 Y	RF turn lamp +
17		NC
18		NC
19		NC
20		NC
21		NC
22		NC

Instrument Harness Connector (I--)

IP Harness to Engine Compartment Harness(CVT) Connector

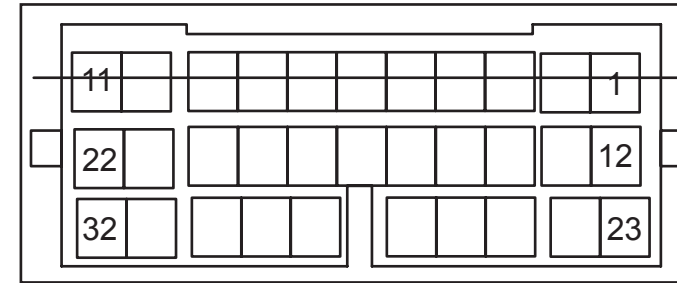

IU2

IU2 Pin Definition

Pin Number	Wire Width / Color	Function
1	0.85 Gr	Wiper/washer motor power
2	1.25 Gr/B	Wiper high speed power +
3	0.50 BI/W	High-beam lamp indicator
4	0.50 BI/Y	Low-beam lamp indicator
5	0.50 BI	Width lamp power+
6	0.50 G/BI	Daytime lamp power
7	0.50 P	Washer power -
8	0.85 O/B	TCM power control
9	0.50 Y/W	TCM power
10	0.85 Gr/Y	Wiper low speed power +
11	0.85 Gr/R	Wiper return
12	1.25 R/W	Fule pump power +
13	0.85 BI/R	TCM power
14	0.50 R/B	ABS ECU IG1 power
15	0.50 W	Turn left lamp power +
16	0.50 Y	Turn right lamp power +
17	0.50 Gr/BI	Rear washer motor power
18	0.50 Y/R	CVT gear indicator
19	0.50 B/W	Start motor relay control
20	0.50 Br/Y	Reverse lmap control(CVT)
21	0.85 B	Ground
22	0.85 B	Ground
23	0.50 W	CAN_L
23	0.50 W/BI	CAN_H(PESP)
24	0.50 W/B	CAN_H
24	0.50 W/B	CAN_L(PESP)
25	0.50 W/G	Reduced speed signal
26	0.50 G	Shift switch signal
27	0.50 Y	Shift switch signal
28	0.50 BI/W	Shift control lock
29	0.50 Y/W	E/D model

Harness Connector View

Instrument Harness Connector (I--)

IU2 Pin Definition

Pin Number	Wire Width / Color	Function
30	0.50 W/G	CVT diagnostic
31	2.00 R/G	Power(PEPS)
32	1.25 R	Power(PEPS)

IP Harness to Engine Compartment Harness Connector

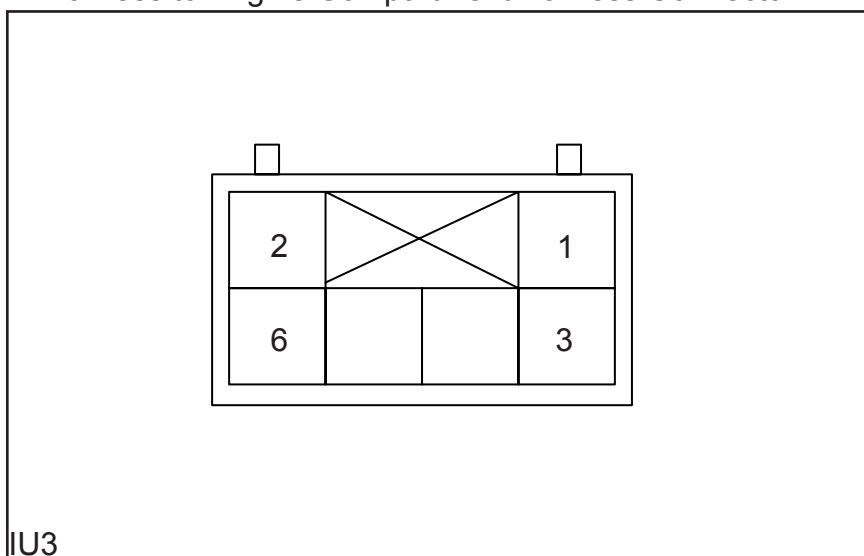

IU3

IU3 Pin Definition

Pin Number	Wire Width / Color	Function
1	0.50 W/G	ESP switch signal
2		NC
3	0.50 W/B	CAN-L
4	0.50 W/BI	CAN-H
5	0.50 W/B	Signal
6	0.50 W	Signal

Instrument Harness Connector (I--)

IP Harness to SRS Harness Connector

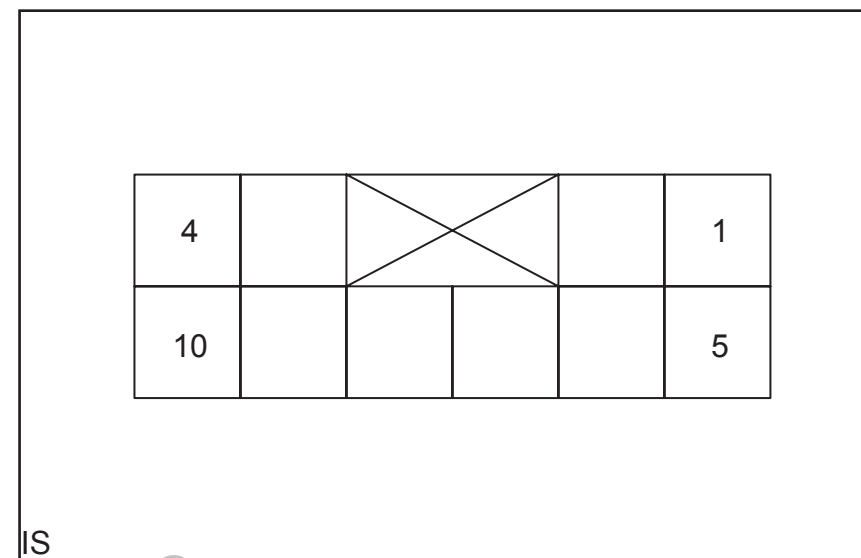

IS

IS Pin Definition

Pin Number	Wire Width / Color	Function
1	0.50 Y/V	RF colision sensor +
2	0.50 Y/Gr	RF colision sensor -
3	0.50 Y/Br	LF colision sensor +
4	0.50 Y/BI	LF colision sensor -
5	0.85 Y/R	Power
6	0.50 G	Air bag indicator
7	0.50 W/R	K-line
8	0.50 G/Y	Colision signal
9		NC
10		NC

Harness Connector View

Instrument Harness Connector (I--)

IP Harness to Body Harness Connector

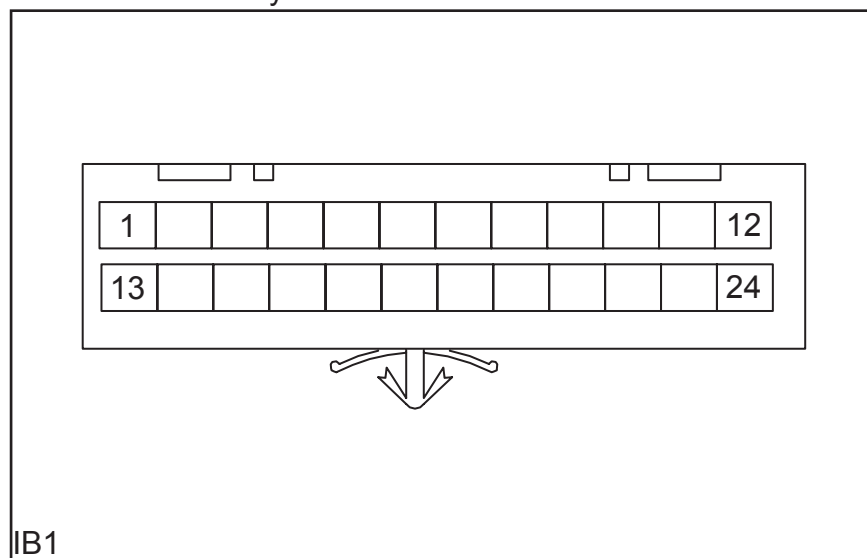

IB1

IP Harness to Body Harness Connector(PEPS)

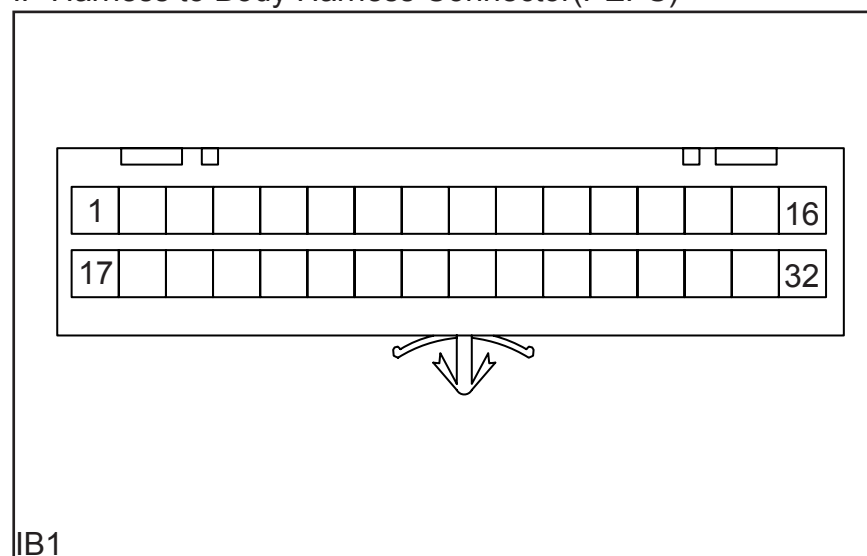

IB1

Instrument Harness Connector (I--)

IB1 Pin Definition

Pin Number	Wire Width / Color	Function
1	0.50 B/W	LF door control switch status signal
2	0.50 B/Y	RF door control switch status signal
3	0.50 B/O	LR door control switch status signal
4	0.50 B/V	RR door control switch status signal
5	0.50 R/Y	Reverse radar +
6	0.50 Gr/R	Left reverse radar signal
7	0.50 W/B	Fuel sensor, reverse radar ground
8	0.50 Gr/W	Right reverse radar signal
9	0.50 G/P	Parking brake switch status signal
10	0.50 P/Y	Fuel sensor signal
11	0.50 Br/P	RR wheel speed sensor signal +
12	0.50 Br/G	RR wheel speed sensor signal -
13	0.50 Br/Gr	LR wheel speed sensor signal +
14	0.50 Br/Bl	LR wheel speed sensor signal -
15	0.50 W/Br	Passenger seat belt switch status signal
16	0.50 W/G	Driver seat belt switch status signal
17	0.50 W/B	CAN-H
18	0.50 G/V	Trunk lamp power
19	0.50 W/G	Left turn lamp power
20	0.50 G	Right turn lamp power
21	0.50 W/B	Tail gate microswitch unlock signal input
22	0.50 W	CAN-L
23	0.50 Bl/Br	Rear Bumper Antenna signal +(PEPS)
24	0.50 Br/B	Rear Bumper Antenna signal -(PEPS)
25	0.50 B/Br	Antenna signal -(PEPS)
26	0.50 V/Br	Antenna signal +(PEPS)
27	0.50 O/B	Antenna signal -(PEPS)
28	0.50 P/Br	Antenna signal +(PEPS)
29	0.50 B	Rear camera signal-(PEPS)
30	0.50 W	Rear camera signal+(PEPS)
31	0.50 G	Rear camera power-(PEPS)
32	0.50 R	Rear camera power+(PEPS)

Harness Connector View

Instrument Harness Connector (I--)

IP Harness to Body Harness Connector

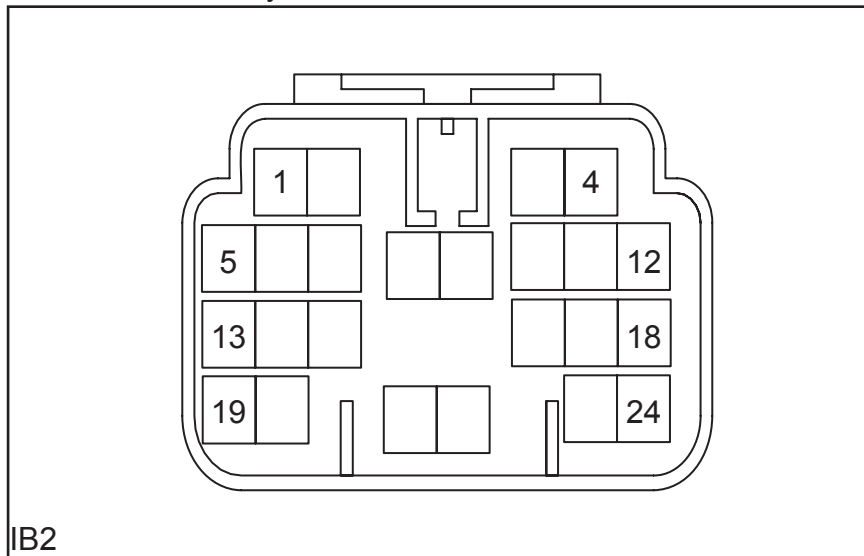

IB2

IB2 Pin Definition

Pin Number	Wire Width / Color	Function
1	0.50 V/O	RR speaker -
2	0.50 V/Y	RR speaker +
3	0.50 V/BI	LR speaker -
4	0.50 V/G	LR speaker +
5	0.50 G/Br	Rear fog lamp power
6	0.50 BI	Rear width lamp power
7	1.25 Y/Br	LR power window up signal
8	1.25 R/W	Fuel pump motor power
9	2.00 P	Rear defroster power
10	1.25 Y/V	LR power window down signal
11	1.25 Y/O	RR power window up signal
12	1.25 Y/P	RR power window down signal
13	0.50 B/P	Trunk switch status signal
14	1.25 R	Power
15	1.25 V/Y	Cigarette lighter power
16	1.25 V/R	Rear left/right door window regulator switch power
16	1.25 Y/R	Rear left/right door window regulator switch power(PEPS)
17	0.50 Br/B	Tail gate motor unlock power output
18	0.50 Br/Y	Lock signal
19	0.50 Br/W	Unlock signal
20	0.50 G/P	Reverse lamp power
21	0.85 Gr	Rear wiper return power
22	0.85 Gr/W	Rear wiper power
23	0.50 G/Gr	Brake lamp power
24	0.50 W/G	ESP switch signal

Instrument Harness Connector (I--)

IP Harness to Engine Harness Connector

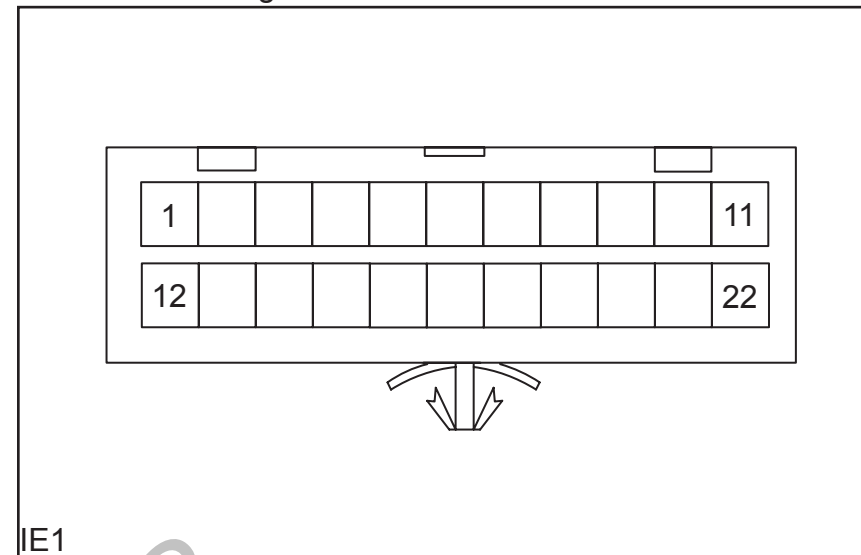

IE1

IE1 Pin Definition

Pin Number	Wire Width / Color	Function
1	0.50 Gr/Y	A/C switch status signal
2	0.85 Y/B	Oil pressure switch status signal
3	0.50 W/BI	Vehicle speed signal
3		NC
4	0.85 W/R	Battery charging indicator
5	0.50 V/W	Engine speed signal
6		NC
6	0.50 B/W	Clutch switch status signal
7	0.50 G/Gr	Brake lamp switch status signal
8	0.50 P/G	K-line
9	0.50 P	Instantaneous fuel consumption signal
9	0.50 W/R	Instantaneous fuel consumption signal(PEPS)
10	0.50 W/Y	SVS fault indicator
11	0.50 G	Engine coolant temperature indicator signal
12	0.50 W/B	Engine speed signal
13	0.50 G/W	Brake switch status signal
14	0.50 P/W	MIL warning indicator
15	0.50 G	EPS switch signal
16		NC
17		NC
18		NC
19		NC
20		NC
21	0.50 R/B	Up shift indicator
22	0.50 R/Y	Down shift indicator

Harness Connector View

Instrument Harness Connector (I--)

Instrument Harness Connector (I--)

IP Harness to Engine Harness Connector

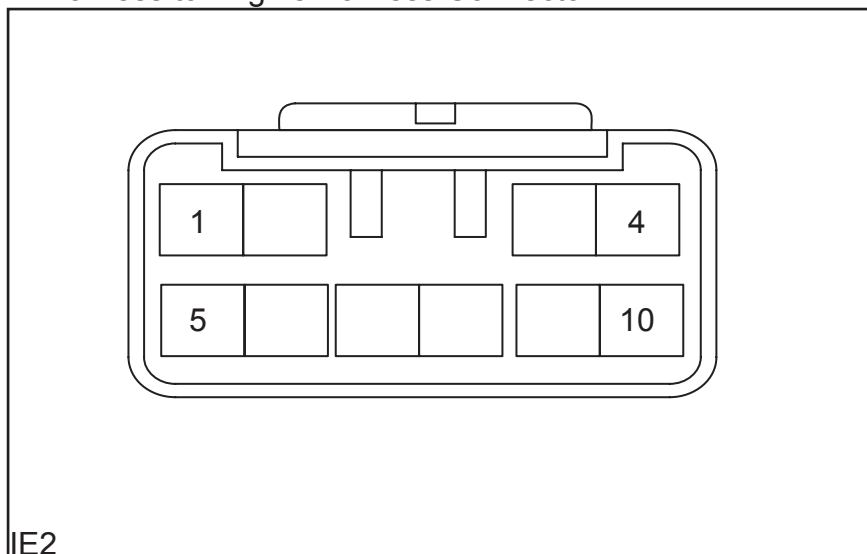

IE2 Pin Definition

Pin Number	Wire Width / Color	Function
1	1.25 B/W	IG1 power
1	1.25 BI/W	IG1 power(PEPS)
2	1.25 BI/W	Ignition switch power
3	1.25 R	Battery power
4	0.50 G/P	Reverse lamp signal
4		NC
5	0.50 G/BI	Reverse lamp switch power
6		NC
7	2.00 B/Y	Start motor power
8		NC
9		NC
10		NC

MachineSoft.IR
09120146259

Harness Connector View

Body Harness Connector (B--)

LF Door Lamp Switch Connector

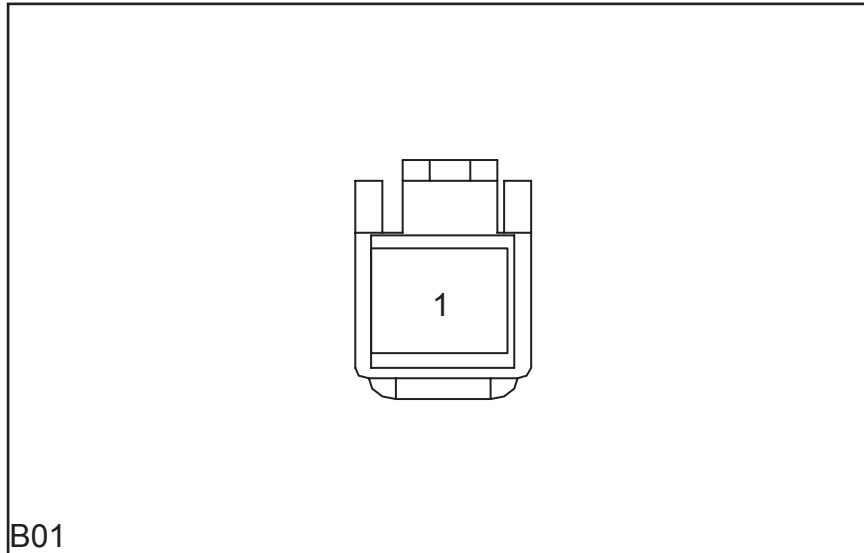

B01

B01 Pin Definition

Pin Number	Wire Width / Color	Function
1	0.50 B/W	Signal

Body Harness Connector (B--)

Cigarette Lighter Connector

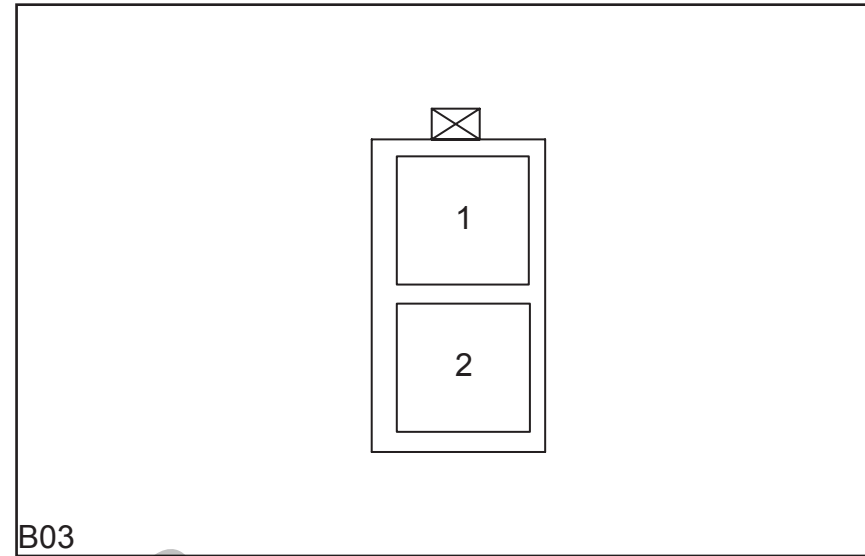

B03

B03 Pin Definition

Pin Number	Wire Width / Color	Function
1	1.25 B	Ground
2	1.25 V/Y	Power

Driver Side Seat Belt Switch Connector

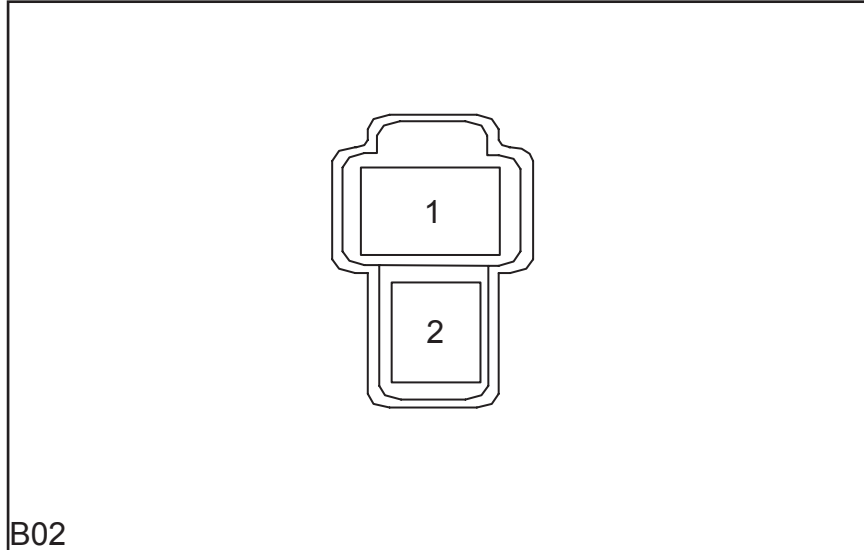

B02

B02 Pin Definition

Pin Number	Wire Width / Color	Function
1	0.50 W/G	Signal
2	0.50 B	Ground

Cigarette Lighter Lighting Connector

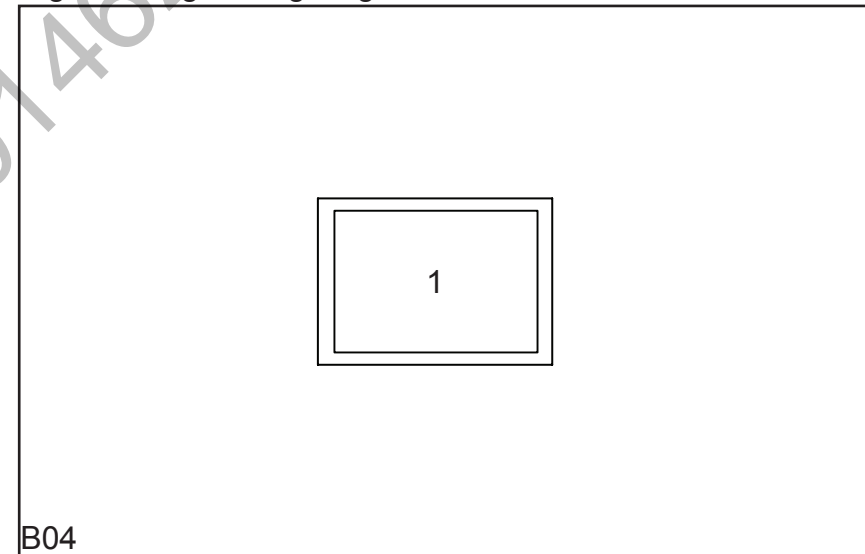

B04

B04 Pin Definition

Pin Number	Wire Width / Color	Function
1	0.50 BI	Background lamp power

Harness Connector View

Body Harness Connector (B--)
Parking Brake Switch Connector

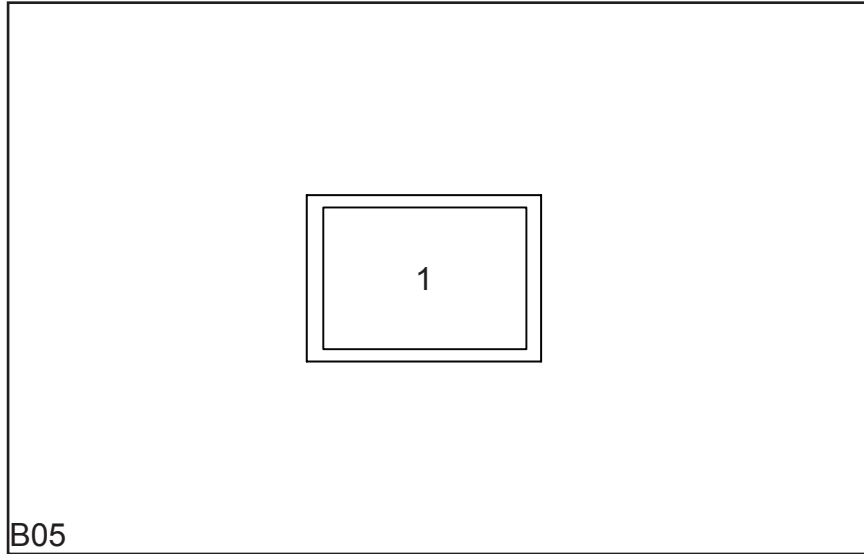

B05

B05 Pin Definition

Pin Number	Wire Width / Color	Function
1	0.50 G/P	Signal

Passenger Side Seat Belt Switch Connector

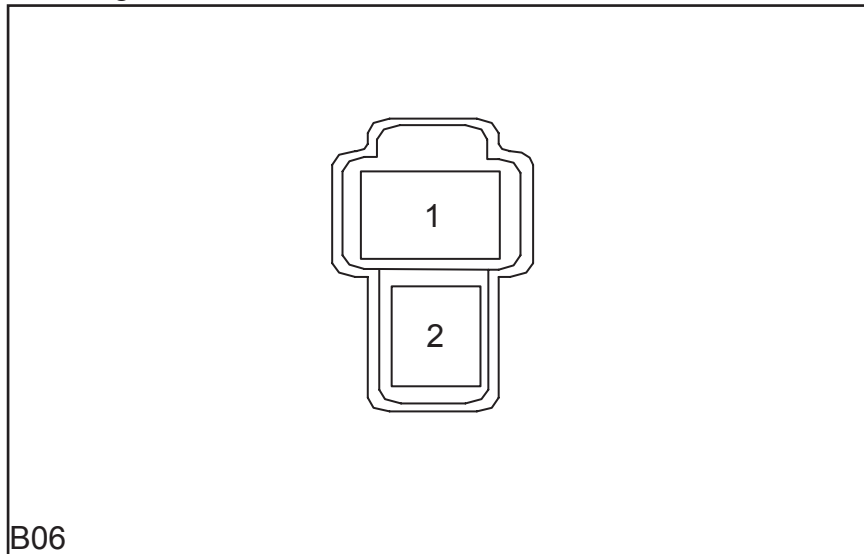

B06

B06 Pin Definition

Pin Number	Wire Width / Color	Function
1	0.50 W/Br	Signal
1	0.50 Gr	Signal(PEPS)
2	0.50 B	Ground

Body Harness Connector (B--)
RF Door Lamp Switch Connector

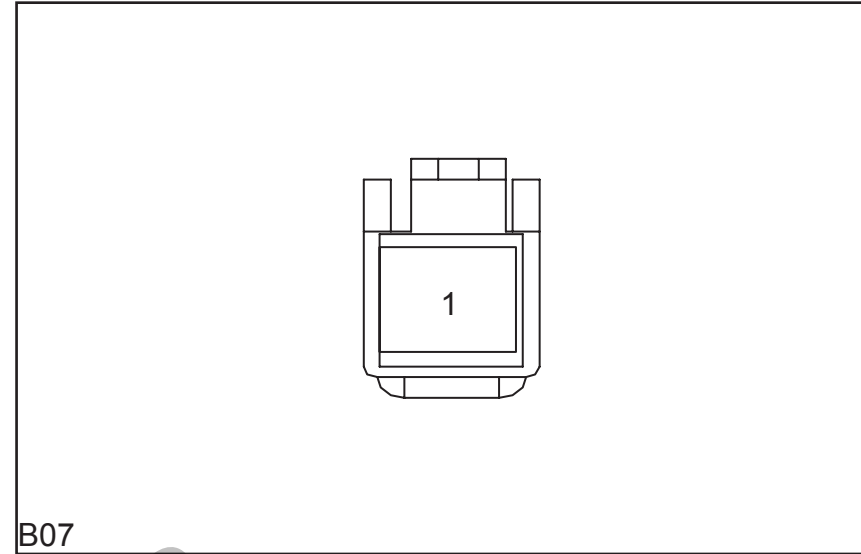

B07

B07 Pin Definition

Pin Number	Wire Width / Color	Function
1	0.50 B/Y	Signal

Fuel Pump Connector

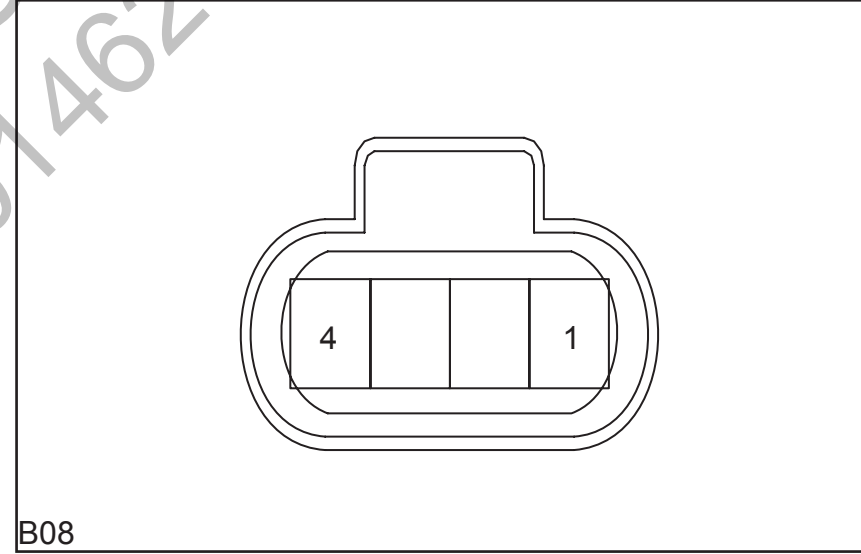

B08

B08 Pin Definition

Pin Number	Wire Width / Color	Function
1	1.25 R/W	Power
2	0.50 P/Y	Signal
3	0.50 W/B	Signal
4	1.25 B	Ground

Harness Connector View

Body Harness Connector (B--)
LR Door Lamp Switch Connector

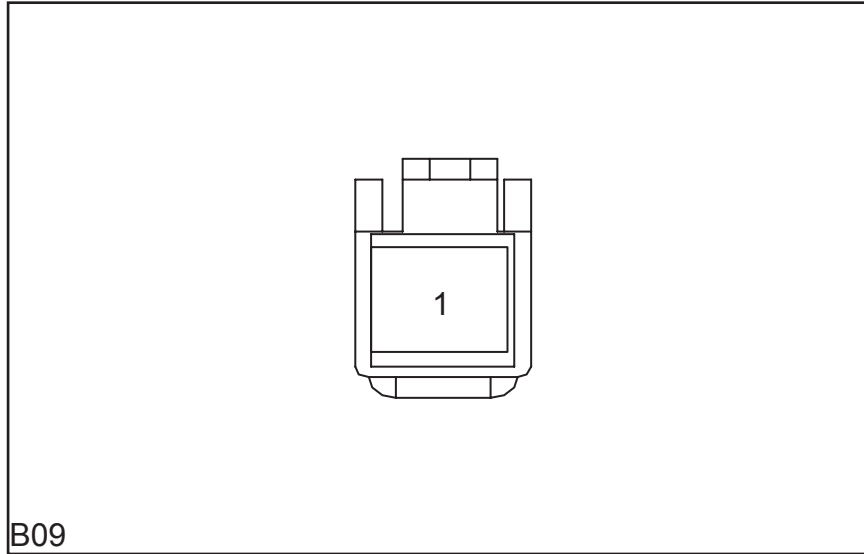

B09

B09 Pin Definition

Pin Number	Wire Width / Color	Function
1	0.50 B/O	Signal

LR WSS Connector

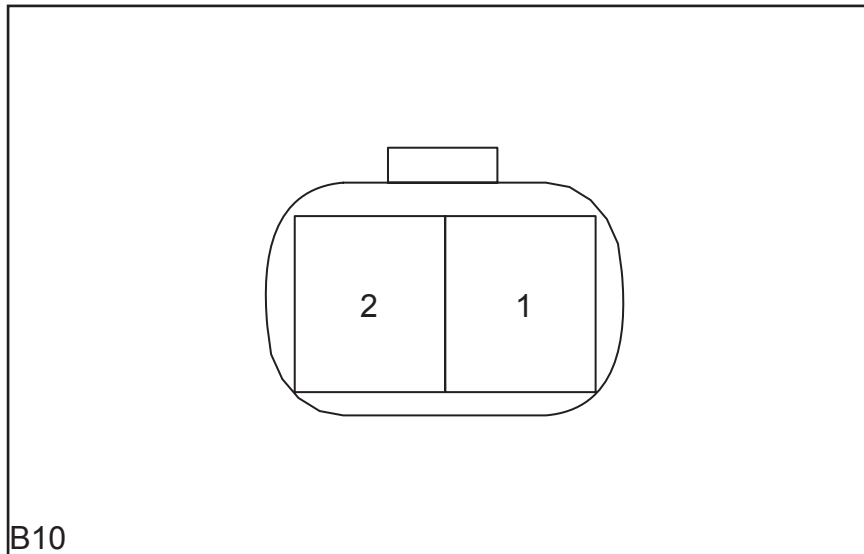

B10

B10 Pin Definition

Pin Number	Wire Width / Color	Function
1	0.50 Br/Bl	Signal
2	0.50 Br/Gr	Signal

Body Harness Connector (B--)
Antenna-2 Connector

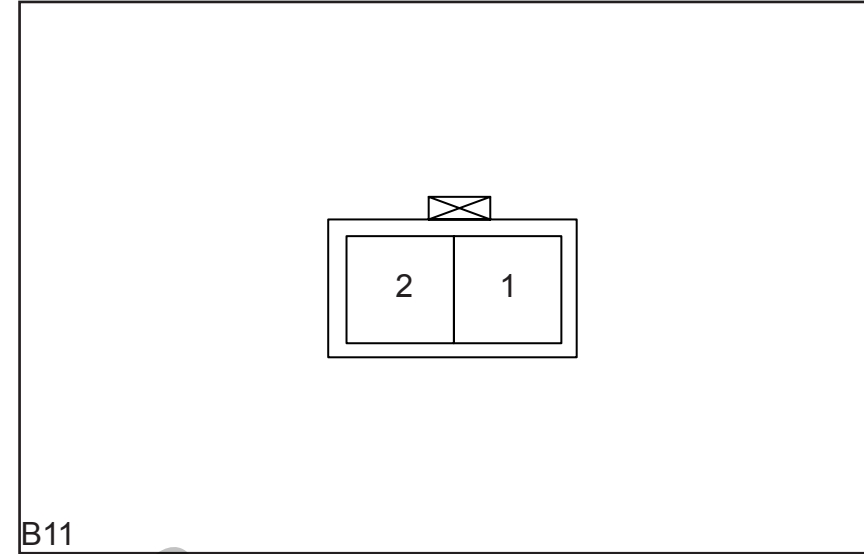

B11

B11 Pin Definition

Pin Number	Wire Width / Color	Function
1	0.50 B/Br	Signal -
2	0.50 V/Br	Signal +

Antenna-3 Connector

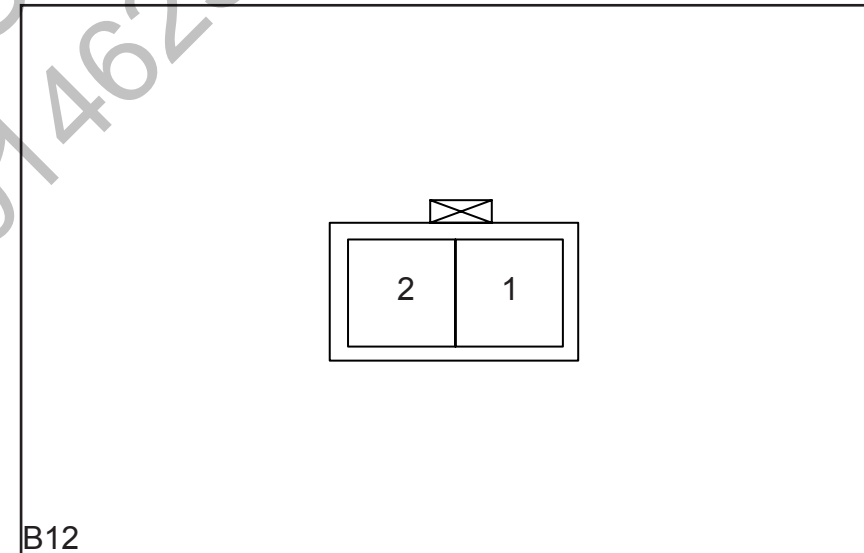

B12

B12 Pin Definition

Pin Number	Wire Width / Color	Function
1	0.50 O/B	Signal -
2	0.50 P/Br	Signal +

Harness Connector View

Body Harness Connector (B--)
Body Yaw Rate Sensor Connector

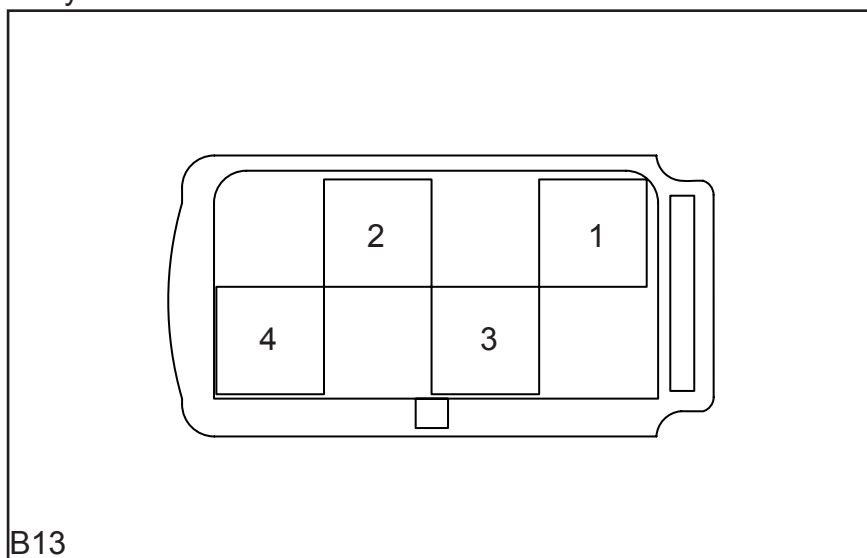

B13

B13 Pin Definition

Pin Number	Wire Width / Color	Function
1	0.50 R/B	Power
2	0.50 W/B	CAN-H/signal
3	0.50 W	CAN-L/signal
4	0.50 B	Ground

Trunk Lamp Connector

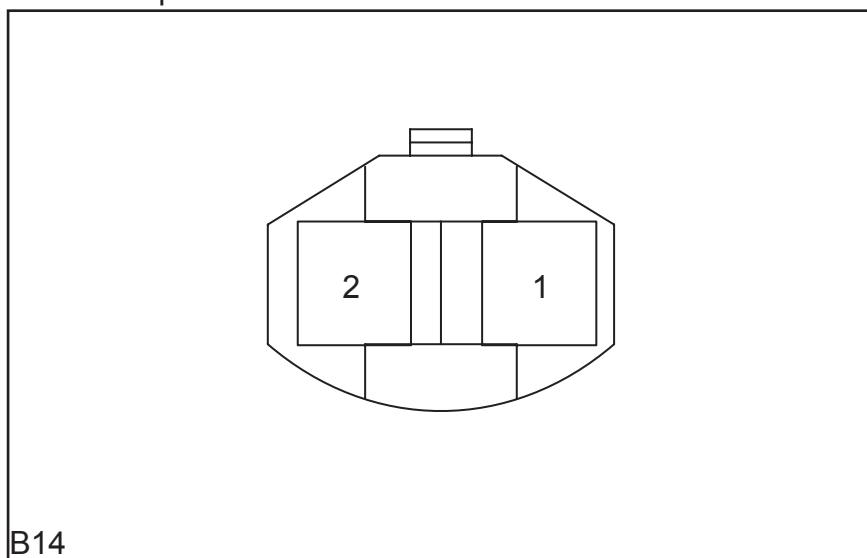

B14

B14 Pin Definition

Pin Number	Wire Width / Color	Function
1	0.50 G/V	Power
2	0.50 B/P	Signal

Body Harness Connector (B--)
ESP Switch Connector

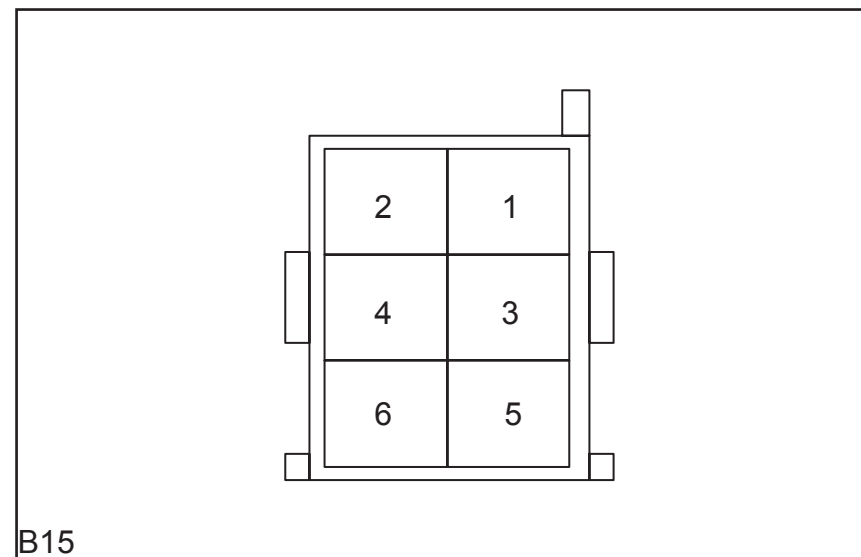

B15

B15 Pin Definition

Pin Number	Wire Width / Color	Function
1		
2	0.50 W/G	Signal
3	0.50 BI	Background lamp power
4	0.50 B	Ground
5		NC
6		NC

LR Combination Lamp Connector

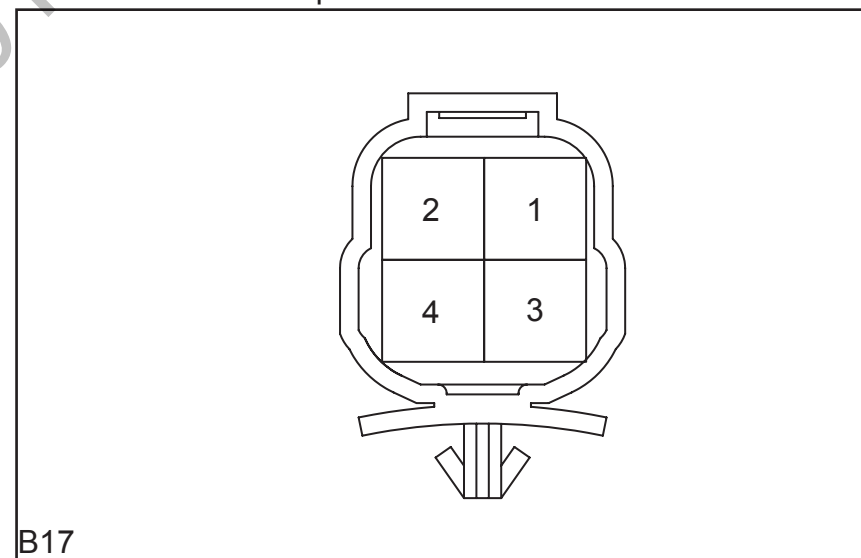

B17

B17 Pin Definition

Pin Number	Wire Width / Color	Function
1	0.50 BI	LR width lamp power
2	0.50 G/Gr	Brake lamp power
3	0.50 W/G	Left rear turn signal lamp power
4	0.50 B	Ground

Harness Connector View

Body Harness Connector (B--)

LR Combination Lamp Connector

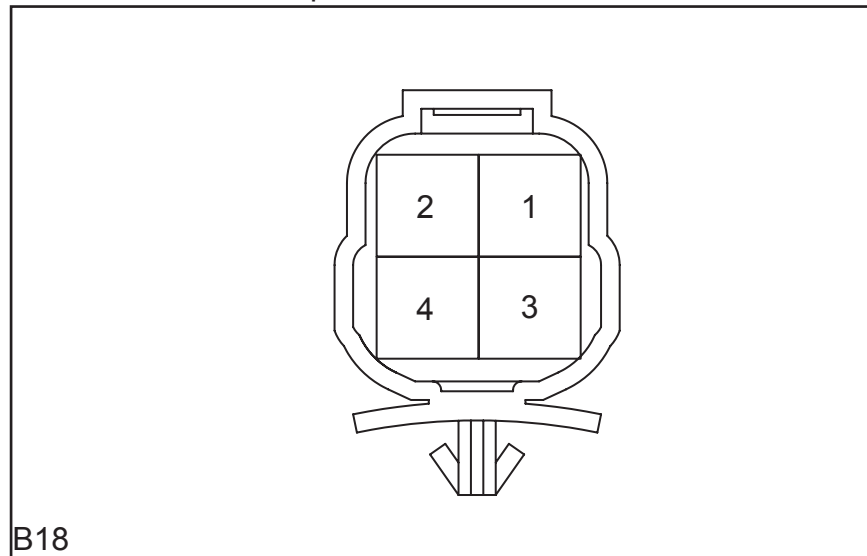

B18

B18 Pin Definition

Pin Number	Wire Width / Color	Function
1	0.50 BI	RR width lamp power
2	0.50 G/Gr	Brake lamp powe
3	0.50 G	Right rear turn signal lamp power
4	0.50 B	Ground

RR Door Lamp Switch Connector

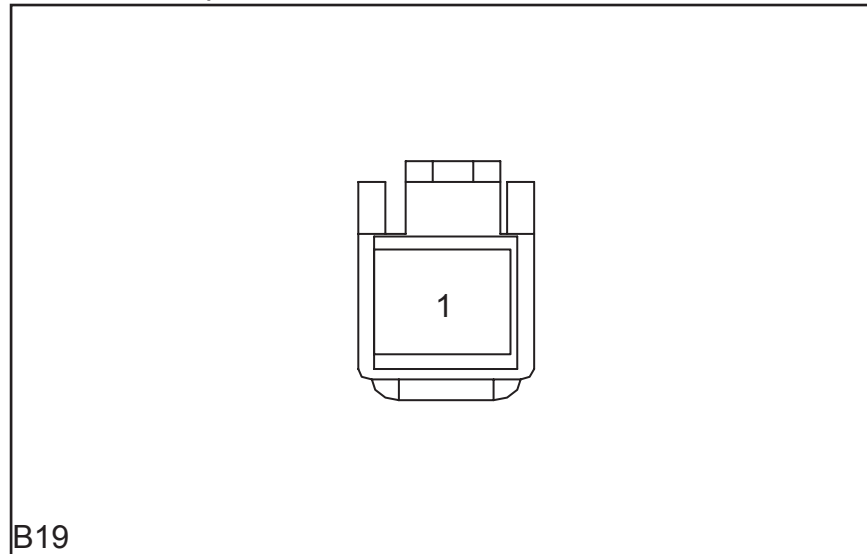

B19

B19 Pin Definition

Pin Number	Wire Width / Color	Function
1	0.50 B/V	Left rear door control switch status signal

Body Harness Connector (B--)

RR WSS Connector

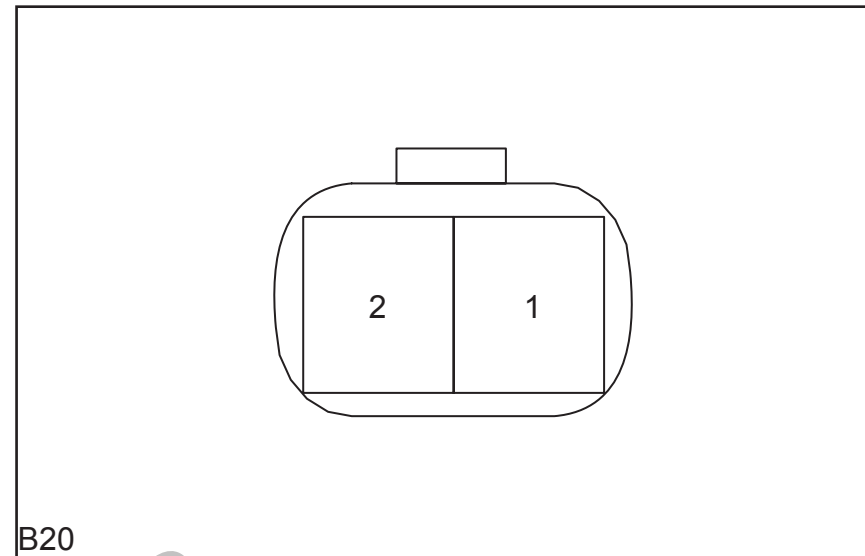

B20

B20 Pin Definition

Pin Number	Wire Width / Color	Function
1	0.50 Br/G	Signal -
2	0.50 Br/P	Signal +

Driver Side Seat Heating Switch(Black) Connector

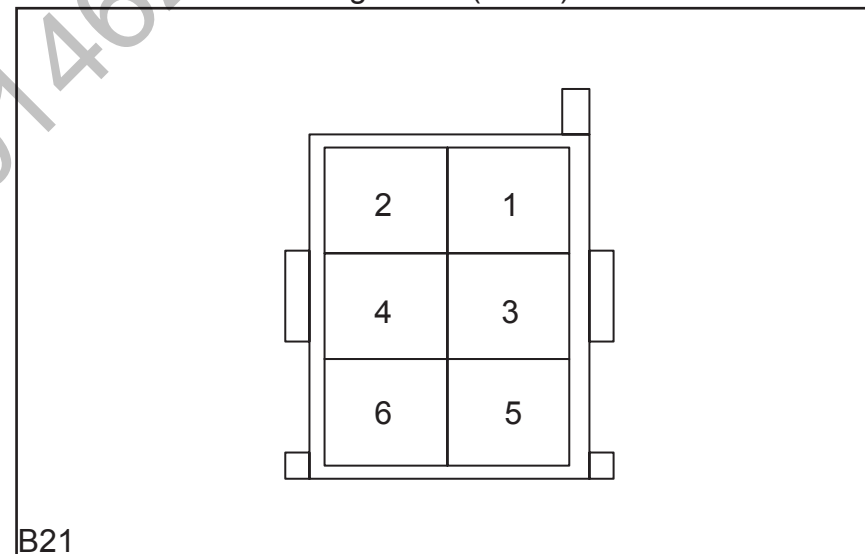

B21

B21 Pin Definition

Pin Number	Wire Width / Color	Function
1	0.50 R	Power
2	0.50 BI	Background lamp power
3	0.50 Y	Signal
4	0.50 B	Ground
5		NC
6		NC

Harness Connector View

Body Harness Connector (B--)

Tail Gate Locking Switch(Green) Connector

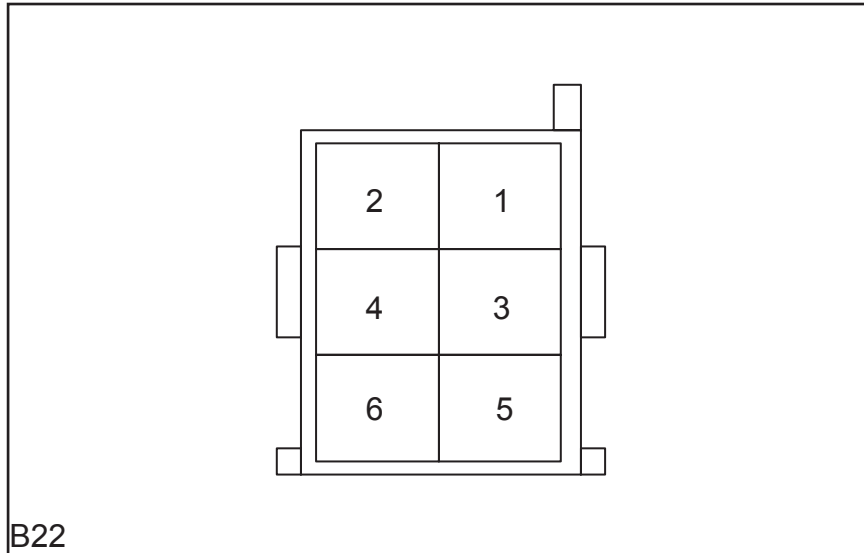

B22

B22 Pin Definition

Pin Number	Wire Width / Color	Function
1		NC
2	0.50 W/B	Signal
3	0.50 BI	Background lamp power
4	0.50 B	Ground
5		NC
6		NC

Body Harness Connector (B--)

Panssenger Side Seat Heating Switch Connector

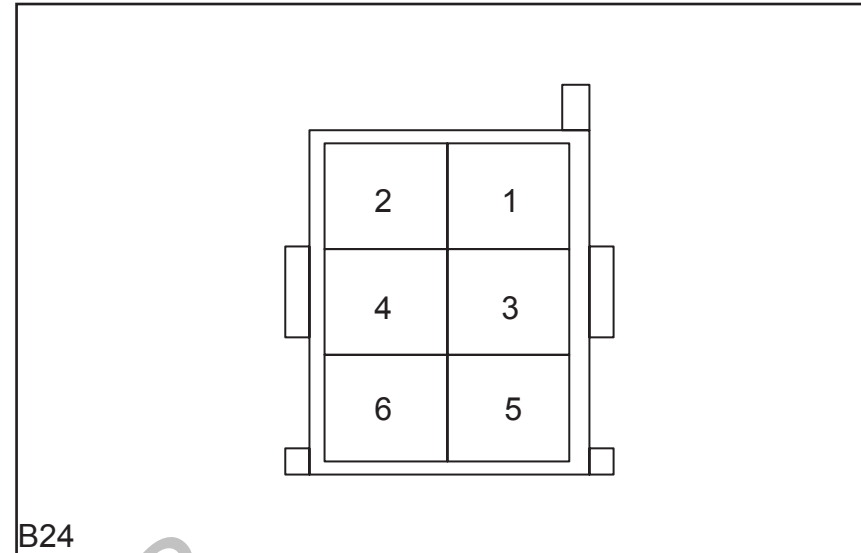

B24

B24 Pin Definition

Pin Number	Wire Width / Color	Function
1	0.50 R	Power
2	0.50 BI	Background lamp power
3	0.50 Y	Signal
4	0.50 B	Ground
5		NC
6		NC

Driver Side Seat Heating Model Connector

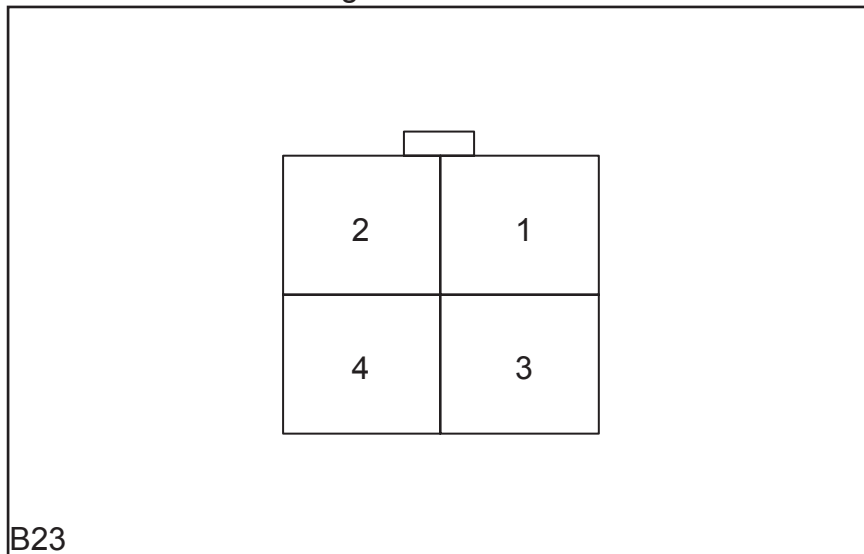

B23

B23 Pin Definition

Pin Number	Wire Width / Color	Function
1		NC
2	1.25 R	Power
3	1.25 B	Ground
4	0.50 Y	Signal

Passenger Side Seat Heating Model Connector

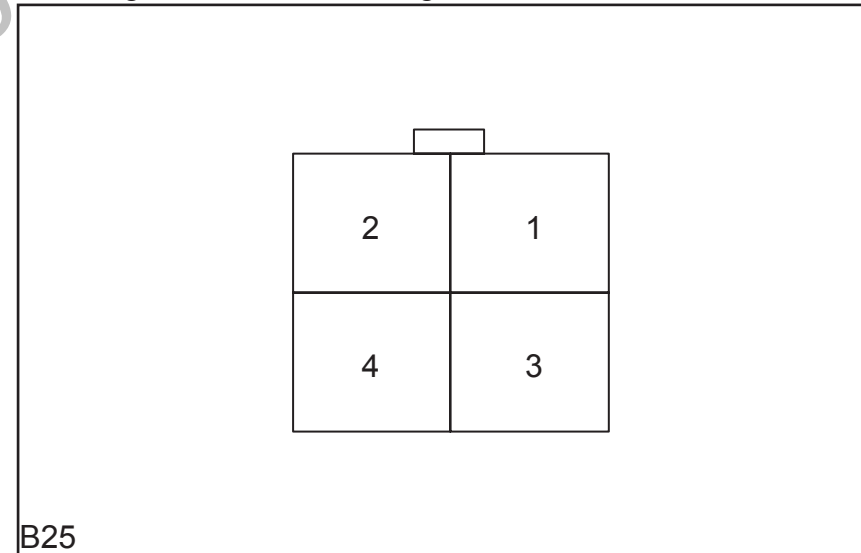

B25

B25 Pin Definition

Pin Number	Wire Width / Color	Function
1		NC
2	1.25 R	Power
3	1.25 B	Ground
4	0.50 Y	Signal

Harness Connector View

Body Harness Connector (B--)

Panssenger Detector sensor Connector

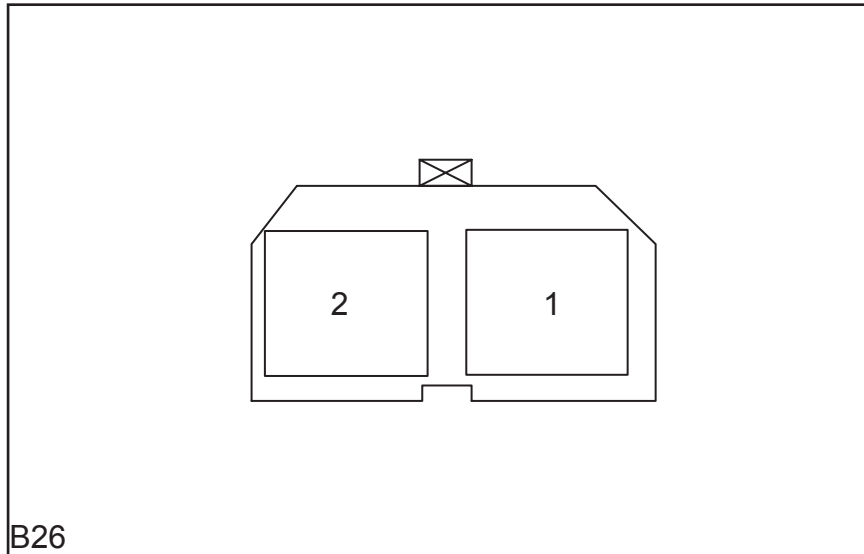

B26

B26 Pin Definition

Pin Number	Wire Width / Color	Function
1	0.50 Gr	Signal
2	0.50 W/Br	Signal

Body Harness to LR Door Harness Connector

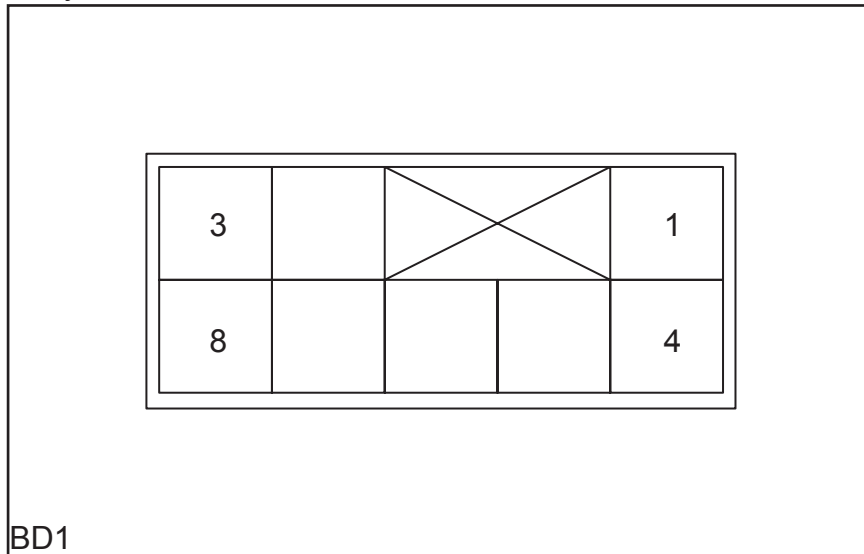

BD1

BD1 Pin Definition

Pin Number	Wire Width / Color	Function
1	1.25 Y/V	LR power window switch down signal
2	1.25 Y/Br	LR power window switch up signal
3	0.50 Br/W	Unlock signal
4	0.50 Br/Y	Lock signa
5	1.25 Y/R	LR power window switch power
6	0.50 V/G	LR speaker power +
7	0.50 V/BI	LR speaker power -
8		NC

Body Harness Connector (B--)

Body Harness to RR Door Harness Connector

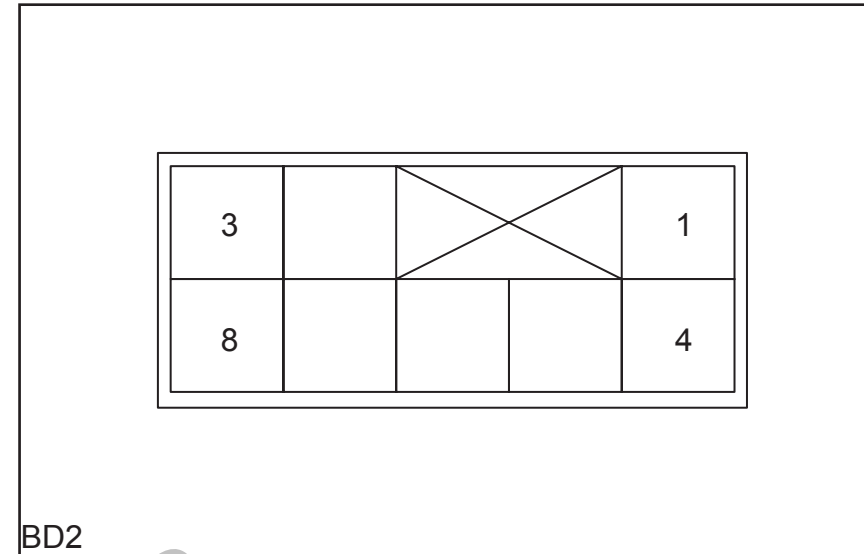

BD2

BD2 Pin Definition

Pin Number	Wire Width / Color	Function
1	1.25 Y/P	RR power window switch down signal
2	1.25 Y/O	RR power window switch up signal
3	0.50 Br/W	Unlock signal
4	0.50 Br/Y	Lock signa
5	1.25 Y/R	RR power window switch power
6	0.50 V/Y	RR speaker power +
7	0.50 V/O	RR speaker power -
8		NC

Harness Connector View

Body Harness Connector (B--)

Body Harness to IP Harness Connector

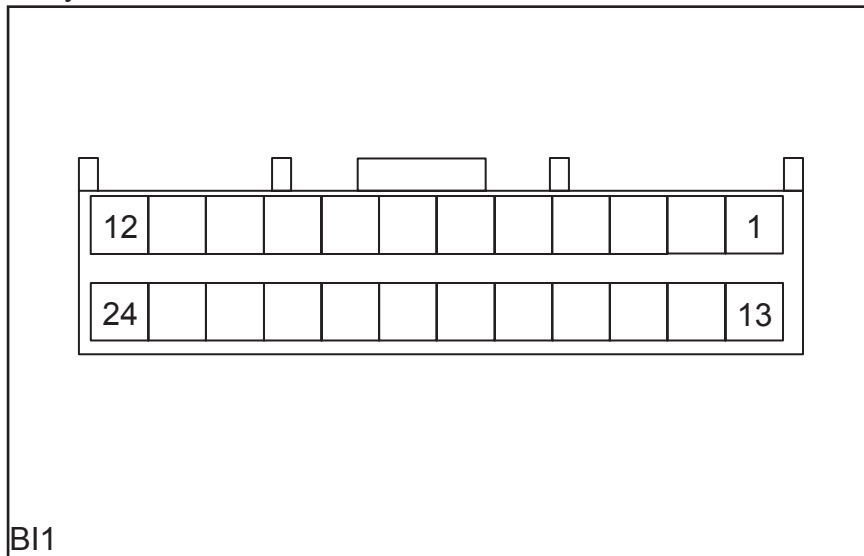

Body Harness to IP Harness Connector(PEPS)

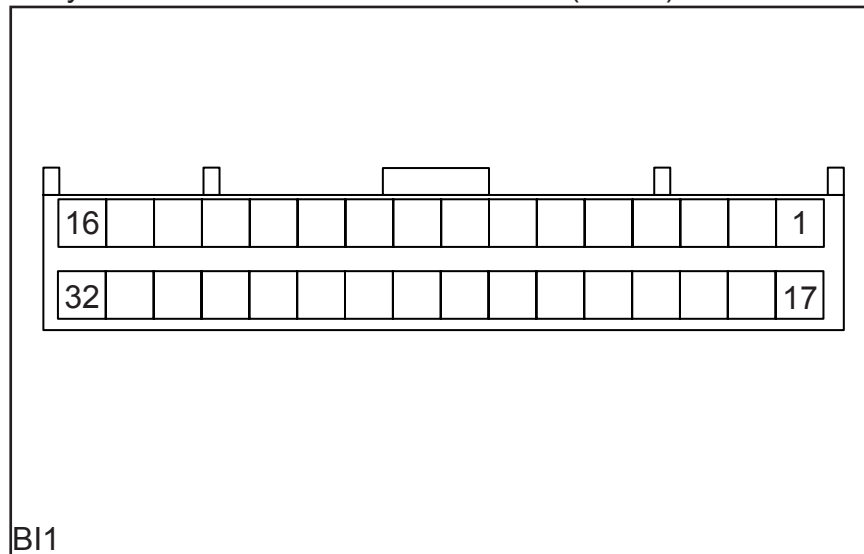

Body Harness Connector (B--)

BI1 Pin Definition

Pin Number	Wire Width / Color	Function
1	0.50 B/W	LF door control switch status signal
2	0.50 B/Y	RF door control switch status signal
3	0.50 B/O	LR door control switch status signal
4	0.50 B/V	RR door control switch status signal
5	0.50 R/Y	Reverse radar +
6	0.50 Gr/R	Left reverse radar signal
7	0.50 W/B	Fuel sensor, reverse radar ground
8	0.50 Gr/W	Right reverse radar signal
9	0.50 G/P	Parking brake switch status signal
10	0.50 P/Y	Fuel sensor signal
11	0.50 Br/P	RR wheel speed sensor signal +
12	0.50 Br/G	RR wheel speed sensor signal -
13	0.50 Br/Gr	LR wheel speed sensor signal +
14	0.50 Br/Bl	LR wheel speed sensor signal -
15	0.50 W/Br	Passenger seat belt switch status signal
16	0.50 W/G	Driver seat belt switch status signal
17	0.50 W/B	signal
18	0.50 G/V	Trunk lamp power
19	0.50 W/G	Left rear turn lamp power
20	0.50 G	Right rear turn lamp power
21	0.50 W/B	Hatchback door microswitch unlock signal input
22	0.50 W	signal
23	0.50 Bl/Br	Rear Bumper Antenna signal +
24	0.50 Br/B	Rear Bumper Antenna signal -
25	0.50 B/Br	Antenna signal -
26	0.50 V/Br	Antenna signal +
27	0.50 O/Br	Antenna signal -
28	0.50 P/Br	Antenna signal +
29	0.50 B	Rear camera signal-(PEPS)
30	0.50 W	Rear camera signal+(PEPS)
31	0.50 G	Rear camera power-(PEPS)
32	0.50 R	Rear camera power+(PEPS)

Harness Connector View

Body Harness Connector (B--)

Body Harness to IP Harness Connector

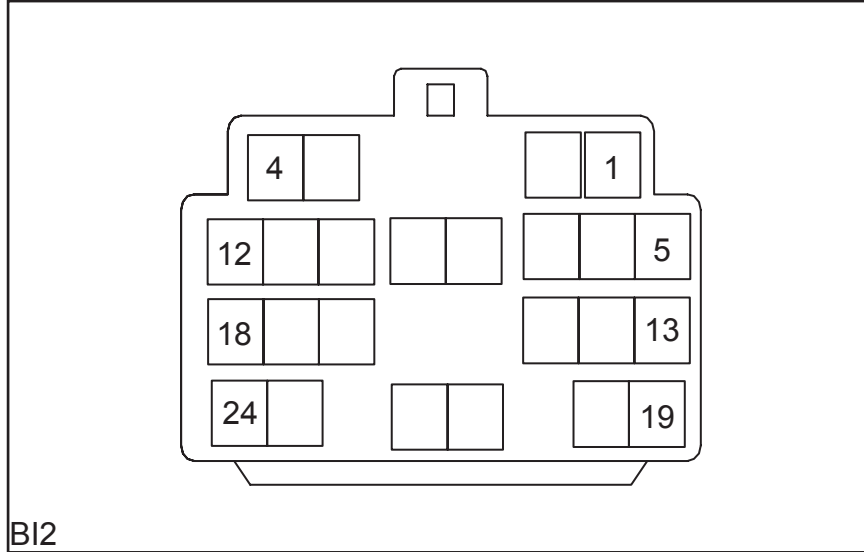

BI2

BI2 Pin Definition

Pin Number	Wire Width / Color	Function
1	0.50 V/O	RR speaker -
2	0.50 V/Y	RR speaker +
3	0.50 V/BI	LR speaker -
4	0.50 V/G	LR speaker +
5	0.50 G/Br	Rear fog lamp power
6	0.50 BI	Rear width lamp power
7	1.25 Y/Br	LR power window up signal
8	1.25 R/W	Fuel pump motor power
9	2.00 P	Rear defroster power
10	1.25 Y/V	LR power window down signal
11	1.25 Y/O	RR power window up signal
12	1.25 Y/P	RR power window down signal
13	0.50 B/P	Trunk switch status signal
14	1.25 R	Power
15	1.25 V/Y	Cigarette lighter power
16	1.25 V/R	Rear left/right door window regulator switch power
16	1.25 Y/R	Rear left/right door window regulator switch power(PEPS)
17	0.50 Br/B	Hatchback door motor unlock power output
18	0.50 Br/Y	Lock signal
19	0.50 Br/W	Unlock signal
20	0.50 G/P	Reverse lamp power
21	0.85 Gr	Rear wiper return power
22	0.85 Gr/W	Rear wiper power
23	0.50 G/Gr	Brake lamp power
24	0.50 W/G	ESP switch signal

Body Harness Connector (B--)

Body Harness to Rear Bumper Harness Connector

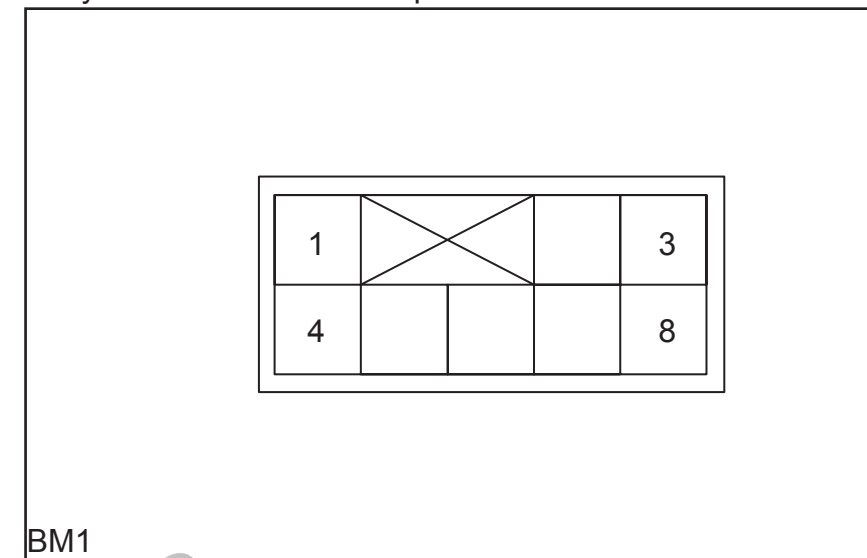

BM1

BM1 Pin Definition

Pin Number	Wire Width / Color	Function
1	0.50 R/Y	Reverse radar signal
2	0.50 Gr/R	Reverse radar signal
3	0.50 Gr/W	Reverse radar signal
4	0.50 BI	Background lamp power
5	0.50 B	Ground
6	0.50 W/B	Reverse radar signal
7	0.50 G/Br	Rear fog lamp power
8	0.50 B	Ground

Harness Connector View

Body Harness Connector (B--)

Body Harness to Rear Bumper Harness Connector

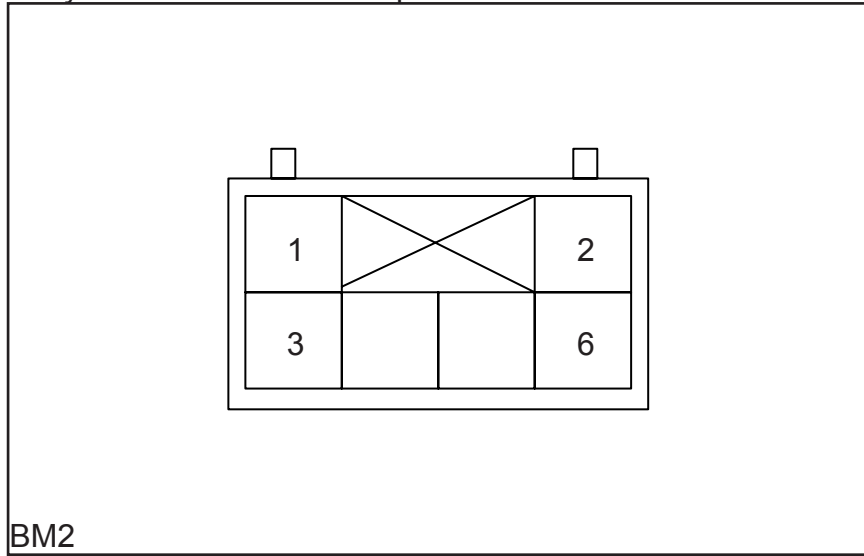

BM2

BM2 Pin Definition

Pin Number	Wire Width / Color	Function
1	0.50 Bl/Br	Rear Bumper Antenna signal +
2	0.50 Br/B	Rear Bumper Antenna signal -
3	0.50 B	Signal -
4	0.50 W	Signal +
5	0.50 G	Power-
6	0.50 R	Power+

Body Harness Connector (B--)

Body Harness to Tail Gate Harness Connector

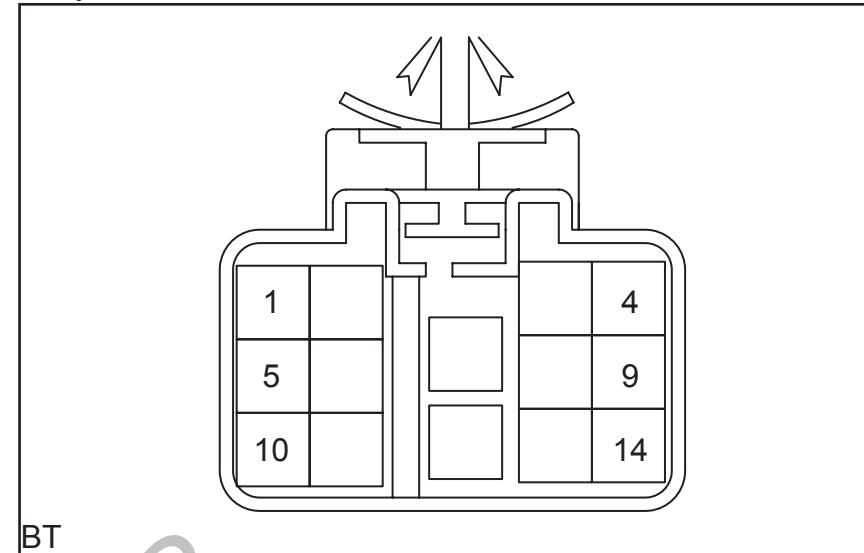

BT

BT Pin Definition

Pin Number	Wire Width / Color	Function
1	0.85 Gr/W	Rear wiper return power
2	0.85 Gr	Rear wiper power
3	0.50 B/P	LR door control switch status signal
4	0.50 Br/B	Hatchback door motor unlock power output
5	0.50 G/Gr	Brake lmap power
6	0.50 B	Left reverse radar signal
7	2.00 P	Rear defroster power
8	0.50 Bl	Right reverse radar signal
8	0.50 G/Gr	Parking brake switch status signal
9	0.50 G/P	Reverse lmap powe
10	0.50 W/B	Hatchback door microswitch unlock signal input
11	2.00 B	RR wheel speed sensor signal -
12		NC
13		NC
14		NC

Harness Connector View

Tail Gate Harness Connector (T--)

High Brake Lamp Connector

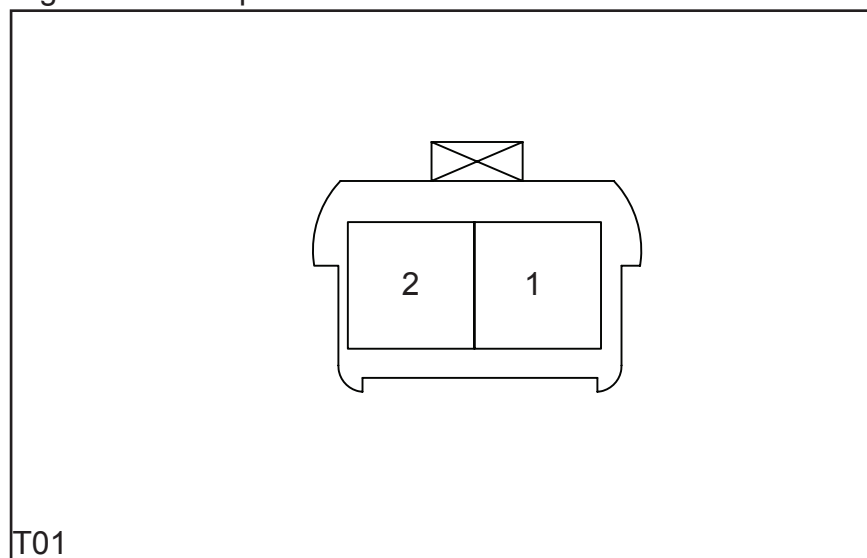

T01

T01 Pin Definition

Pin Number	Wire Width / Color	Function
1	0.50 G/Gr	Power
2	0.50 B	Ground

Rear Dfroster Connector

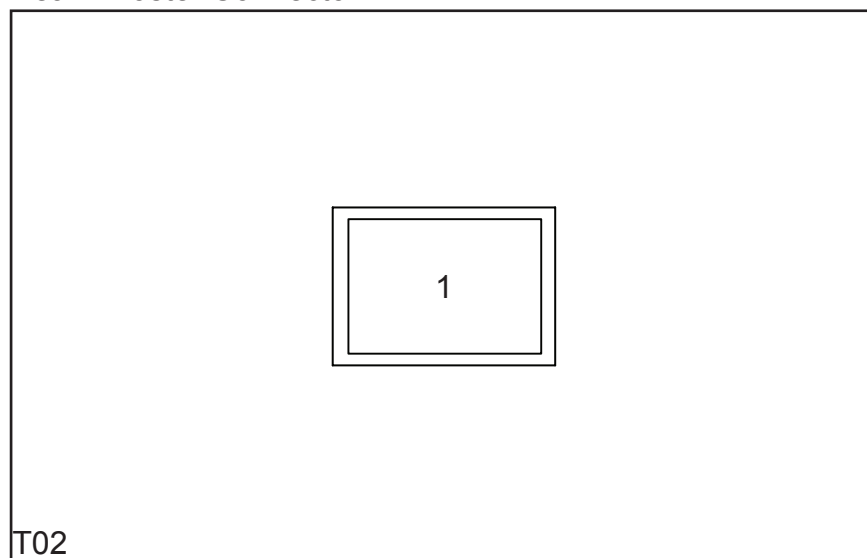

T02

T02 Pin Definition

Pin Number	Wire Width / Color	Function
1	2.00 P	Rear defroster power

Tail Gate Harness Connector (T--)

Tail Gate Harness to Body Harness Connector

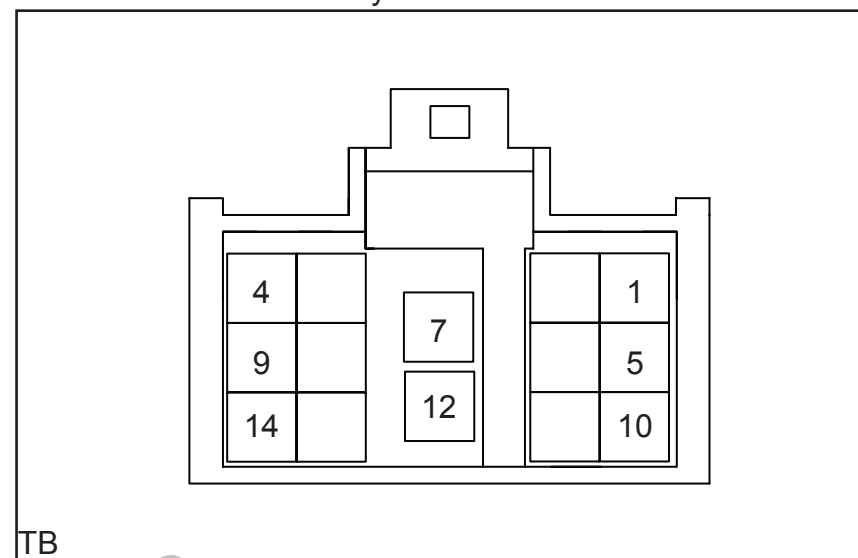

TB

TB Pin Definition

Pin Number	Wire Width / Color	Function
1	0.85 Gr/W	Rear wiper return power
2	0.85 Gr	Rear wiper power
3	0.50 B/P	LR door control switch status signal
4	0.50 Br/B	Hatchback door motor unlock power output
5	0.50 G/Gr	Brake lmap power
6	0.50 B	Left reverse radar signal
7	2.00 P	Rear defroster power
8	0.50 Bl	Right reverse radar signal
8	0.50 Gr	Right reverse radar signal(PEPS)
9	0.50 G/Gr	Parking brake switch status signal
9	0.50 G	Parking brake switch status signal(PEPS)
10	0.50 G/P	Reverse lmap power
11	0.50 W/B	Hatchback door microswitch unlock signal input
12	2.00 B	RR wheel speed sensor signal -
13		NC
14		NC

Harness Connector View

Tail Gate Harness Connector (T--)

Tail Gate Harness Connector

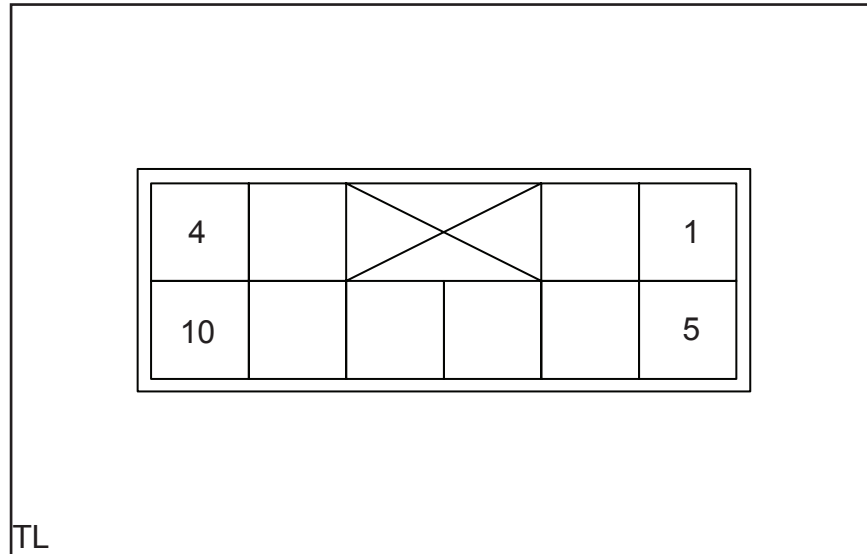

TL Pin Definition

Pin Number	Wire Width / Color	Function
1	0.85 Gr/W	Rear wiper return power
2	0.85 Gr	Rear wiper power
3	0.50 B/P	LR door control switch status signal
4	0.50 Br/B	Hatchback door motor unlock power output
5	0.50 BI	Background lamp power
5	0.50 Gr	Background lamp power(PEPS)
6	0.50 G/Gr	Brake lmap power
6	0.50 G	Brake lmap power(PEPS)
7	0.50 G/P	Reverse lmap power
8	0.50 W/B	Hatchback door microswitch unlock signal input
9	2.00 P	Parking brake switch status signal
9	2.00 B	Parking brake switch status signal(PEPS)
10		NC

Tail Gate Harness Connector (T--)

Harness Connector View

Tail Gate Harness Connector (L--)

Rear Wiper Motor Connector

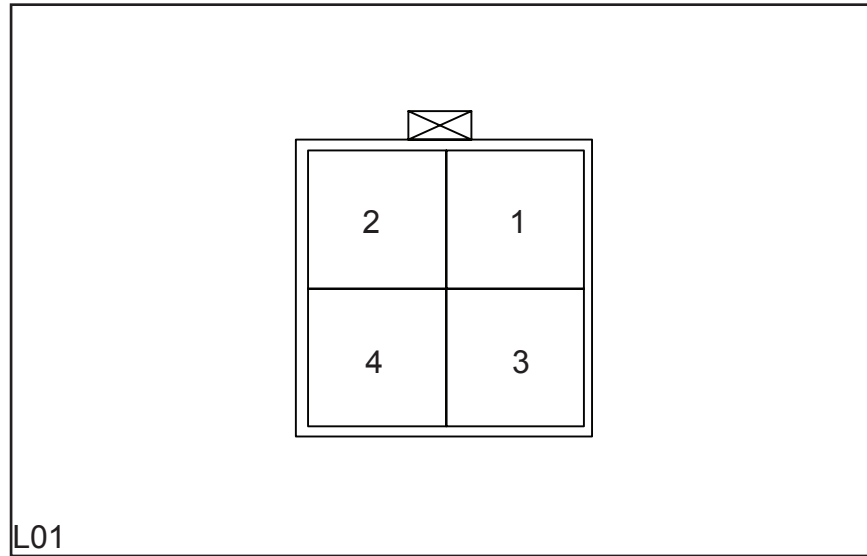

L01

L01 Pin Definition

Pin Number	Wire Width / Color	Function
1		NC
2	0.85 Gr	Return power
3	0.85 Gr/W	Power
4	0.85 B	Ground

RR Combination Lamp Connector

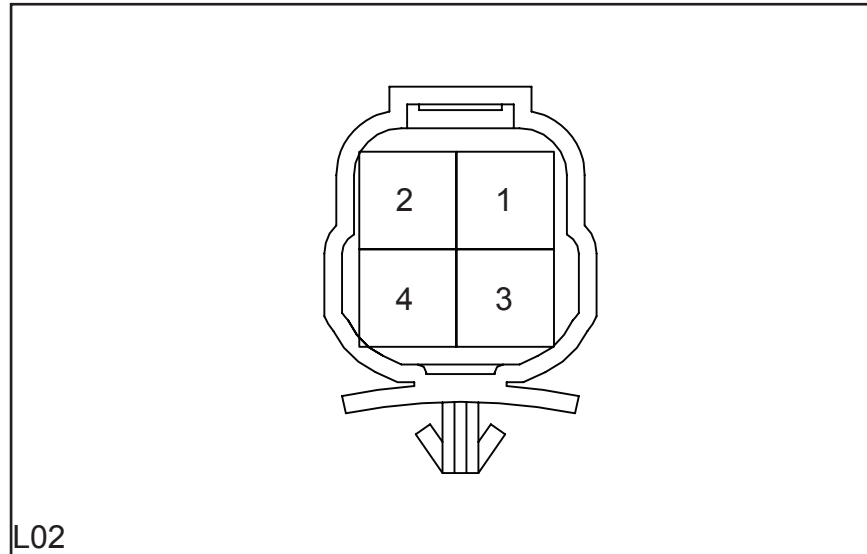

L02

L02 Pin Definition

Pin Number	Wire Width / Color	Function
1	0.50 Bl	RR width lamp power
2	0.50 G/Gr	Brake lamp power
3	0.50 G/P	Reverse lamp power
4	0.50 B	Ground

Tail Gate Harness Connector (L--)

Trunk Lamp Switch Connector

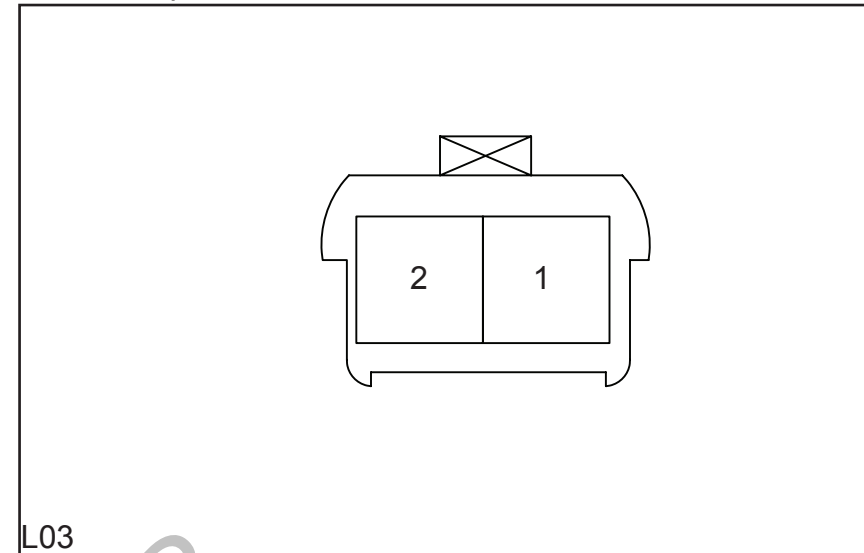

L03

L03 Pin Definition

Pin Number	Wire Width / Color	Function
1	0.50 B/P	Signal
2	0.50 B	Ground

Tail Gate Locking Connector

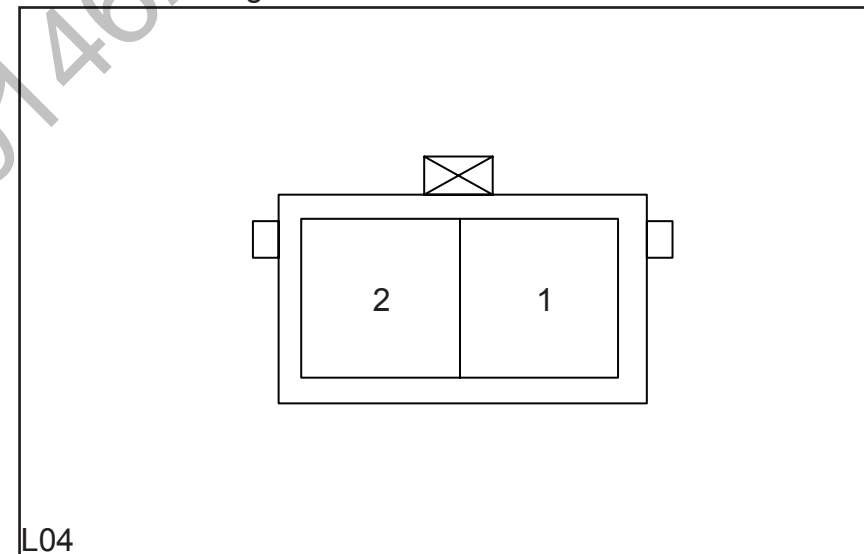

L04

L04 Pin Definition

Pin Number	Wire Width / Color	Function
1	0.50 Br/B	Unlock power output
2	0.50 B	Ground

Harness Connector View

Tail Gate Harness Connector (L--)

Tail Gate Microswitch Connector

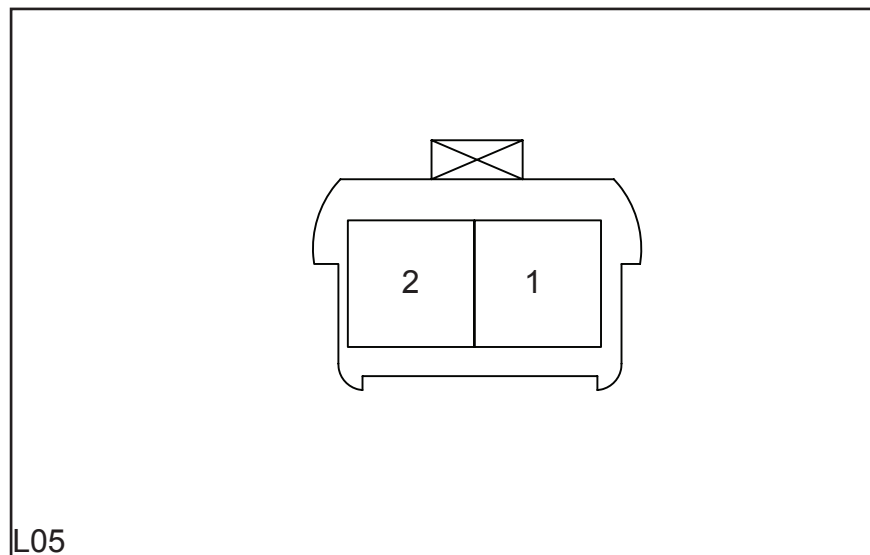

L05

L05 Pin Definition

Pin Number	Wire Width / Color	Function
1	0.50 W/B	Hatchback door microswitch unlock signal input
2	0.50 B	Ground

LR Combination Lamp Connector

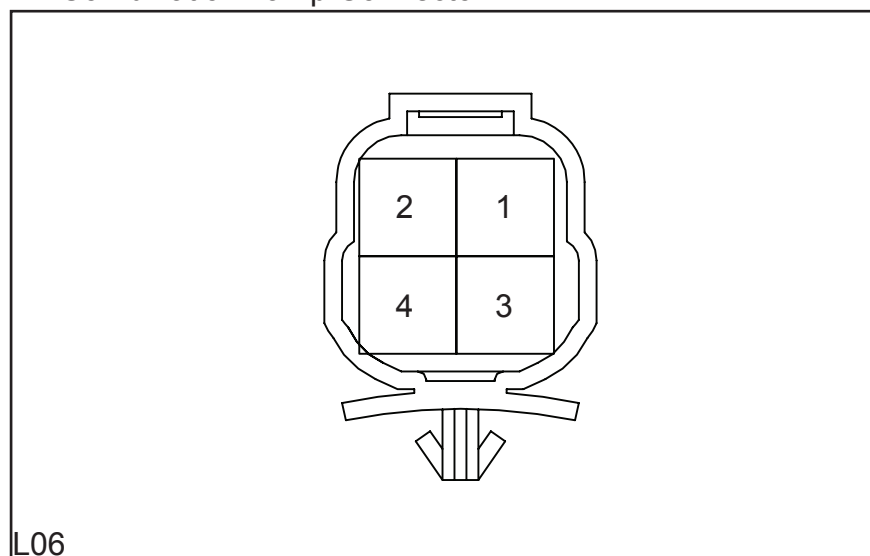

L06

L06 Pin Definition

Pin Number	Wire Width / Color	Function
1	0.50 BI	LR width lamp power
2	0.50 G/Gr	Brake lamp power
3	0.50 G/P	Reverse lamp power
4	0.50 B	Ground

Tail Gate Harness Connector (L--)

Tail Gate Harness Connector

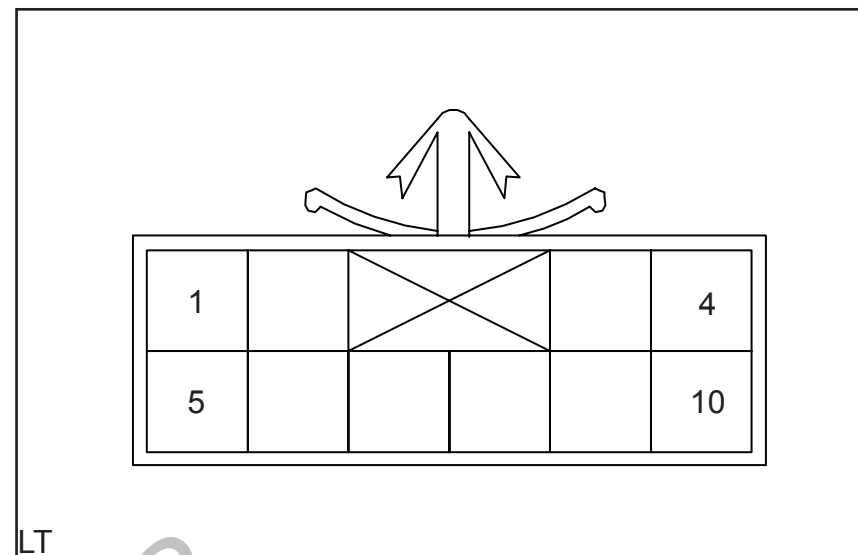

LT

LT Pin Definition

Pin Number	Wire Width / Color	Function
1	0.85 Gr/W	Rear wiper return power
2	0.85 Gr	Rear wiper power
3	0.50 B/P	LR door control switch status signal
4	0.50 Br/B	Hatchback door motor unlock power output
5	0.50 BI	Background lamp power
6	0.50 G/Gr	Brake lmap power
7	0.50 G/P	Reverse lmap power
8	0.50 W/B	Hatchback door microswitch unlock signal input
9	2.00 P	Parking brake switch status signal
9	2.00 B	Parking brake switch status signal(PEPS)
10		NC

Harness Connector View

Door Harness Connector(D--)

LF Power Window Motor Connector

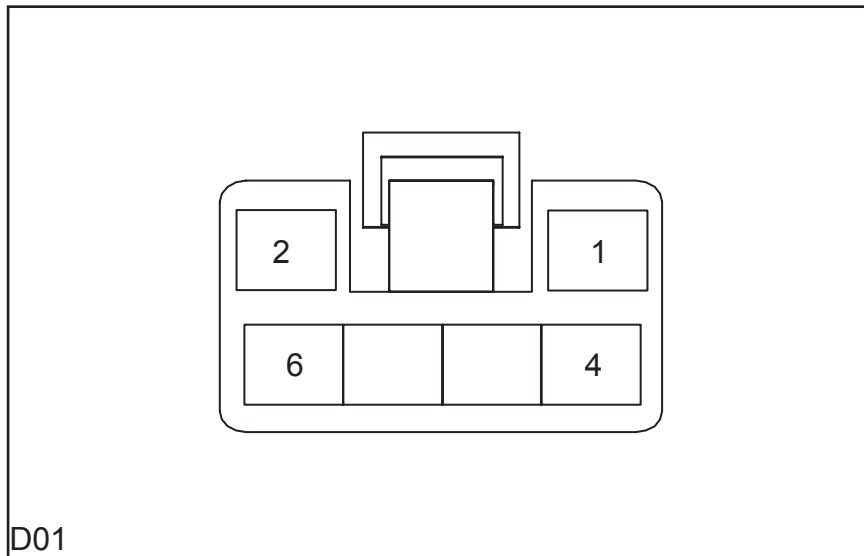

D01 Pin Definition

Pin Number	Wire Width / Color	Function
1		NC
2		NC
3		NC
4	1.25 Y/B	LF power window switch down signal
5	1.25 Y/W	LF power window switch up signal
6		NC

Left Outside Rearview Mirror Connector

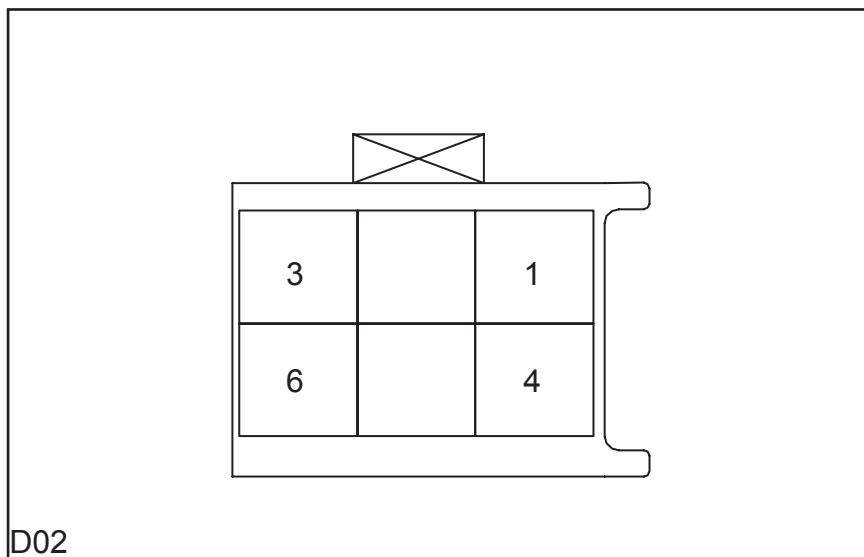

D02 Pin Definition

Pin Number	Wire Width / Color	Function
1	0.50 Y/Br	Left outside rearview turn left/right power
2	0.50 P	Left outside rearview heating power
3	0.50 G/W	Left side turn lamp power
4	0.50 Y/G	Left outside rearview turn up/down power
5	0.50 Y/W	Left front power window switch down signal
6	0.50 B	Ground

Door Harness Connector(D--)

LF Door Speaker Connector

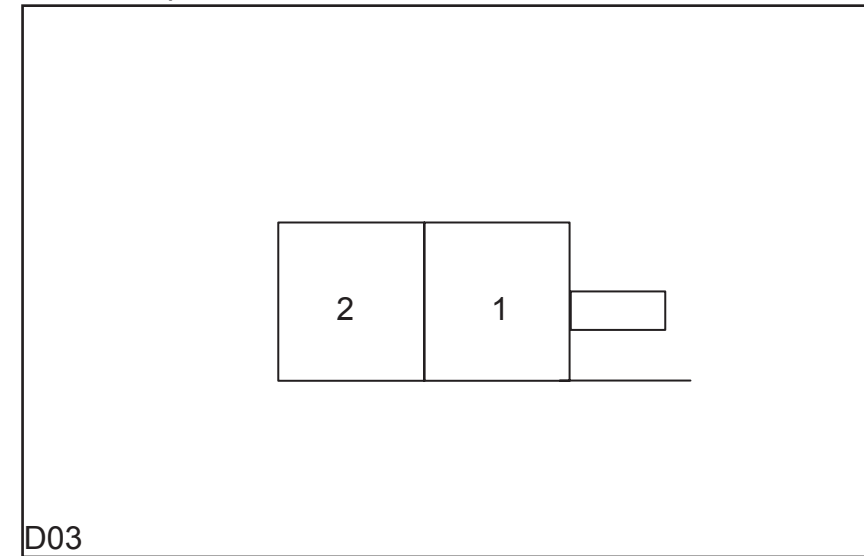

D03 Pin Definition

Pin Number	Wire Width / Color	Function
1	0.50 V/W	Speaker +
2	0.50 V/B	Speaker -

LF Door Power Window Switch Connector

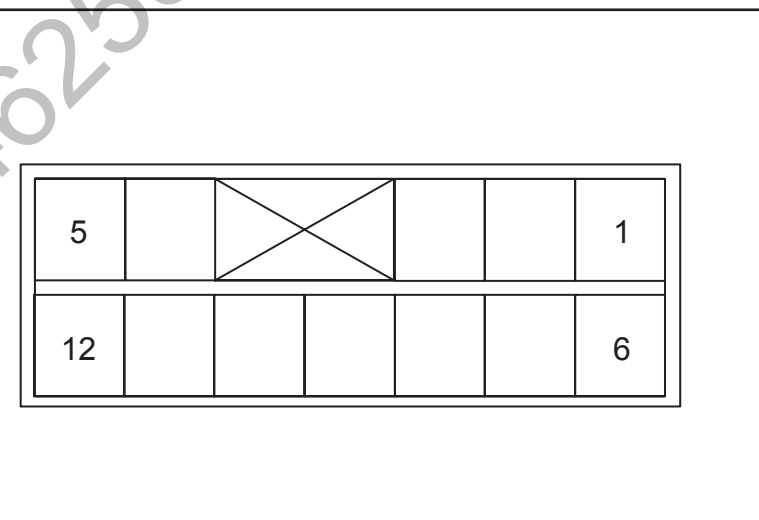

D04 Pin Definition

Pin Number	Wire Width / Color	Function
1	1.25 Y/Bl	RF power window switch up signal
2	1.25 Y/G	RF power window switch down signal
3	1.25 Y	Power
4	1.25 Y/B	LF power window switch down signal
5	1.25 Y/W	LF power window switch up signal
6	2.00 Y/R	Power window switch power
7	1.25 Y/P	RR power window switch down signal
8	1.25 Y/O	RR power window switch up signal
9	2.00 B	Ground
10	2.00 Y	Power
11	1.25 Y/V	LR power window switch up signal
12	1.25 Y/Br	LR power window switch down signal

Harness Connector View

Door Harness Connector(D--)

LF Door Locking Connector

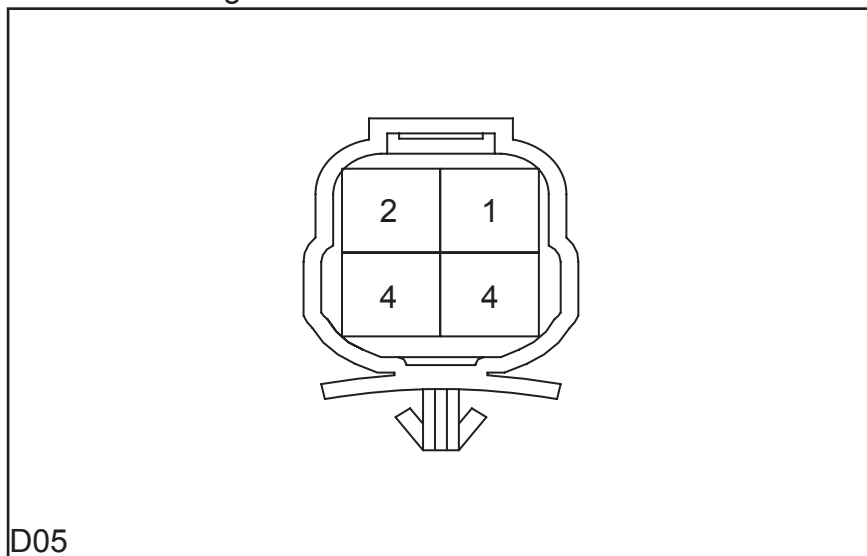

D05

D05 Pin Definition

Pin Number	Wire Width / Color	Function
1	0.50 Br/Y	lock signal
2	0.50 Br/W	Unlock signal
3	0.50 B	Ground
4	0.50 Br	LF door lock switch status power

RF Power Window Motor Connector

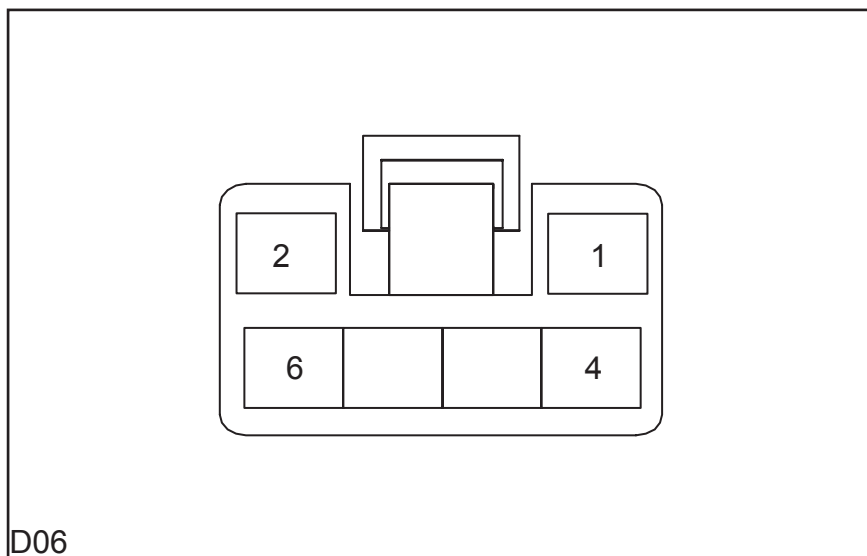

D06

D06 Pin Definition

Pin Number	Wire Width / Color	Function
1		NC
2		NC
3		NC
4	1.25 Y/Br	RF power window switch down signal
5	1.25 Y/V	RF power window switch up signal
6		NC

Door Harness Connector(D--)

Right Outside Rearview Mirror Connector

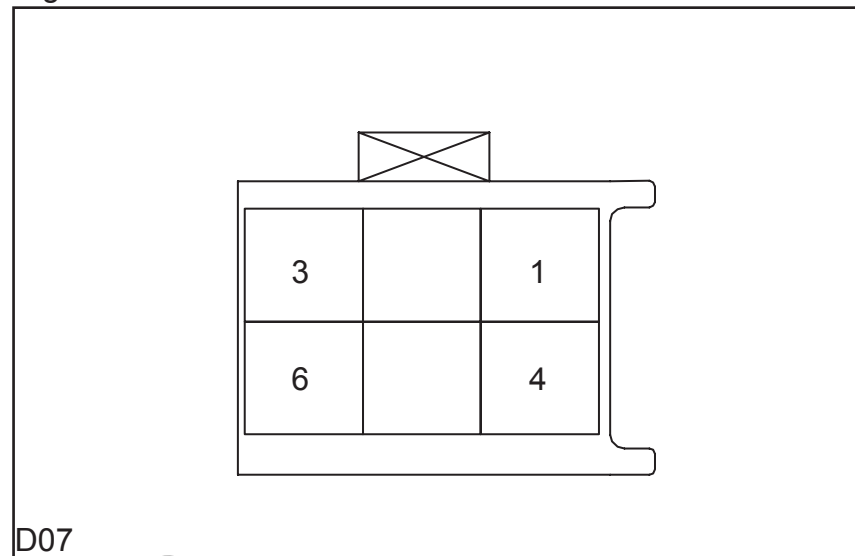

D07

D07 Pin Definition

Pin Number	Wire Width / Color	Function
1	0.50 Y/Gr	Right outside rearview left/right power
2	0.50 P	Right outside rearview heating power
3	0.50 G/Y	Right side turn lamp power
4	0.50 Y/BI	Right outside rearview up/down power
5	0.50 Y/W	Right front power window switch down signal
6	0.50 B	Ground

RF Door Speaker Connector

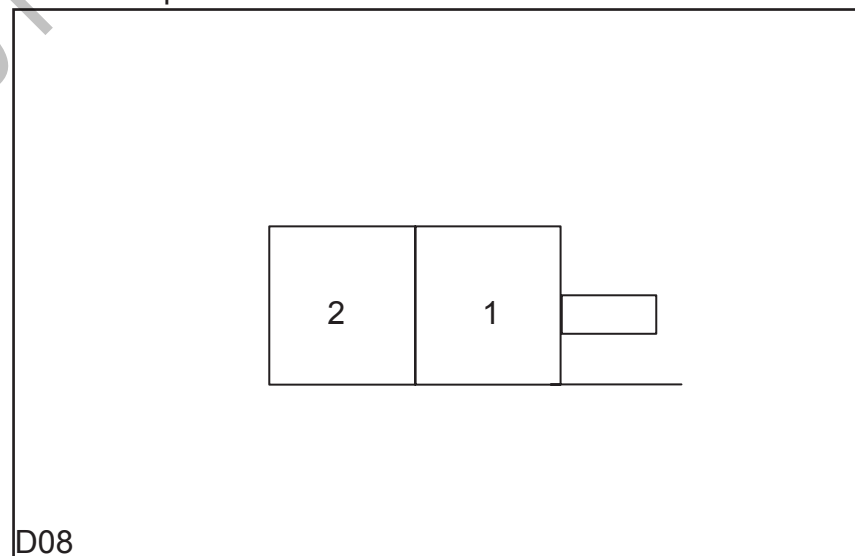

D08

D08 Pin Definition

Pin Number	Wire Width / Color	Function
1	0.50 V/Gr	Speaker -
2	0.50 V/Br	Speaker +

Harness Connector View

Door Harness Connector(D--)

RF Power Window Switch Connector

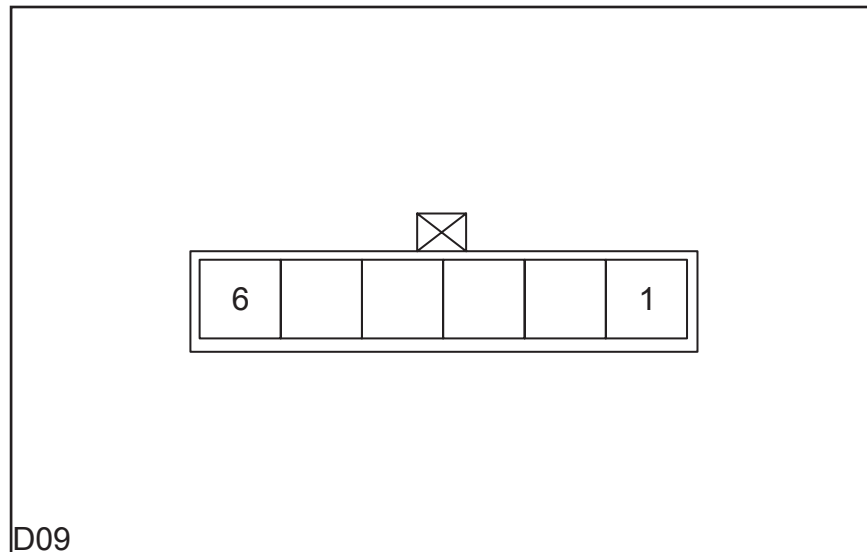

D09

D09 Pin Definition

Pin Number	Wire Width / Color	Function
1	1.25 Y/R	RF power window switch power
2	1.25 Y/G	RF power window switch down signal
3		NC
4	1.25 Y/Br	RF power window switch down signal
5	1.25 Y/V	RF power window switch up signal
6	1.25 Y/Bl	RF power window switch up signal

RF Door Locking Connector

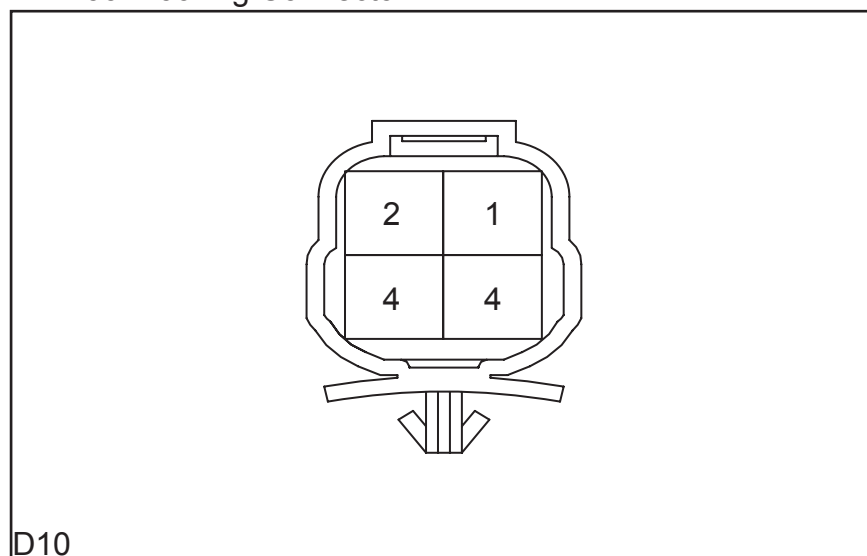

D10

D10 Pin Definition

Pin Number	Wire Width / Color	Function
1	0.50 Br/Y	Lock signal
2	0.50 Br/W	Unlock signal
3		NC
4		NC

Door Harness Connector(D--)

LR Power Window Motor Connector

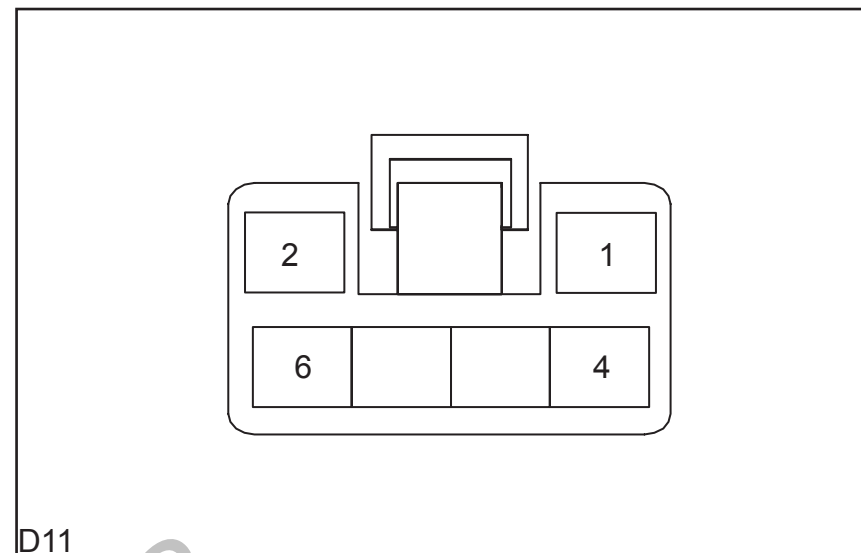

D11

D11 Pin Definition

Pin Number	Wire Width / Color	Function
1		NC
2		NC
3		NC
4	1.25 Y/G	LR power window switch up signal
5	1.25 Y/Bl	LR power window switch down signal
6		NC

LR Power Window Switch Connector

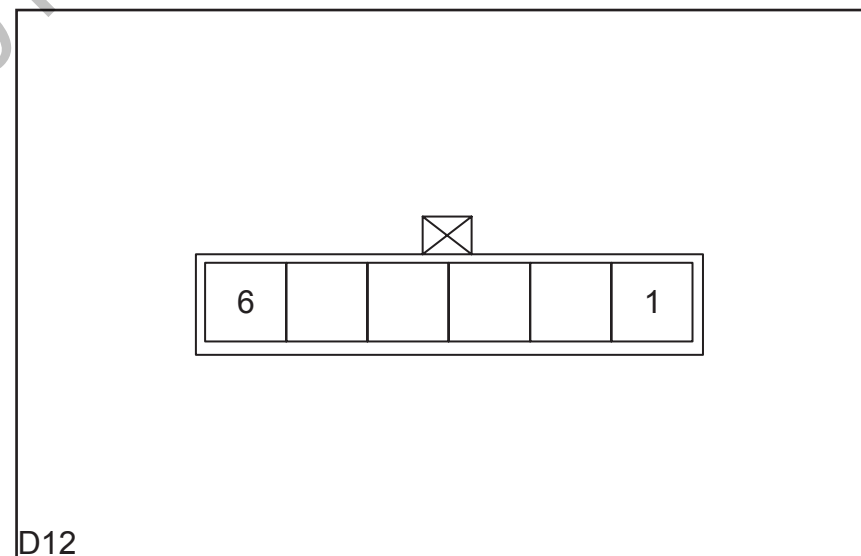

D12

D12 Pin Definition

Pin Number	Wire Width / Color	Function
1	1.25 Y/R	LR power window switch power
2	1.25 Y/V	LR power window switch down signal
3		NC
4	1.25 Y/Bl	LR power window switch down signal
5	1.25 Y/G	LR power window switch up signal
6	1.25 Y/Br	LR power window switch up signal

Harness Connector View

Door Harness Connector(D--)

LR Door Locking Connector

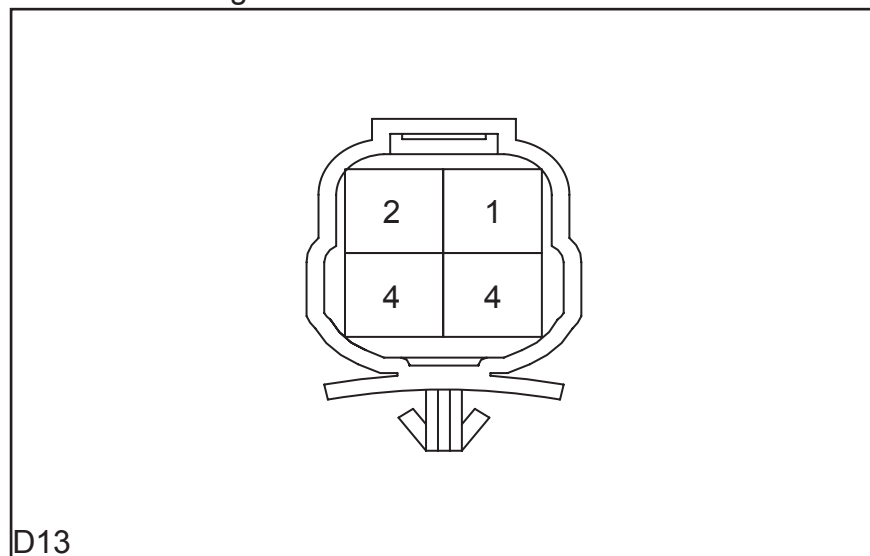

D13

D13 Pin Definition

Pin Number	Wire Width / Color	Function
1	0.50 Br/Y	Lock signal
2	0.50 Br/W	Unlock powe
3		NC
4		NC

LR Speaker Connector

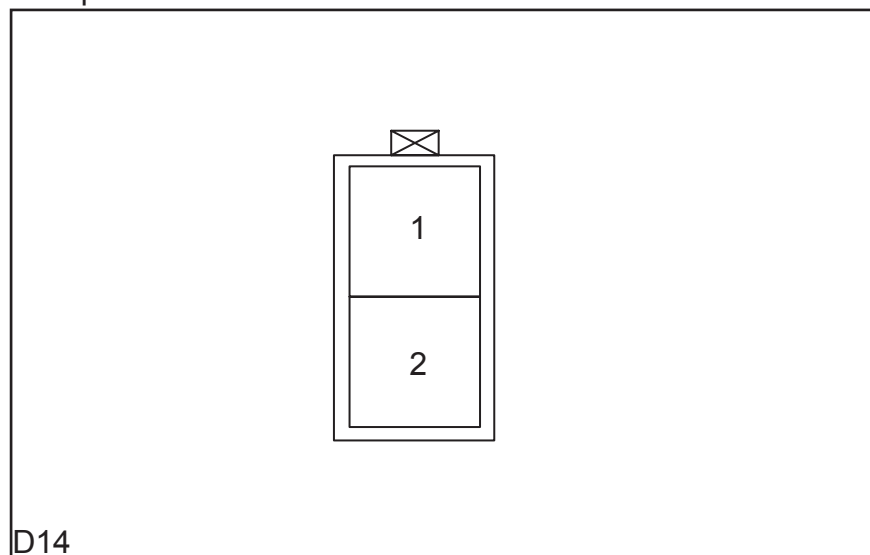

D14

D14 Pin Definition

Pin Number	Wire Width / Color	Function
1	0.50 V/G	Speaker +
2	0.50 V/Bl	Speaker -

Door Harness Connector(D--)

RR Power Window Motor Connector

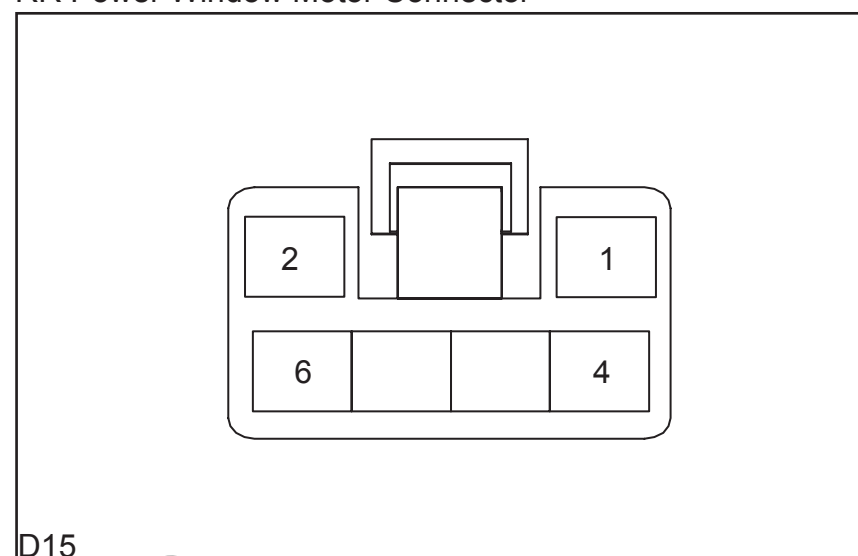

D15

D15 Pin Definition

Pin Number	Wire Width / Color	Function
1		NC
2		NC
3		NC
4	1.25 Y/P	RR power window switch up signal
5	1.25 Y/O	RR power window switch down signal
6		NC

RR Power Window Switch Connector

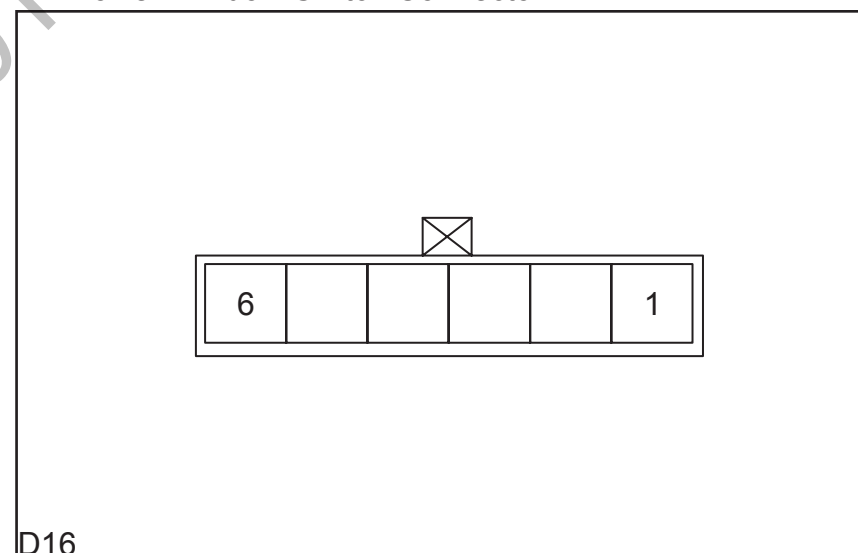

D16

D16 Pin Definition

Pin Number	Wire Width / Color	Function
1	1.25 Y/R	RR power window switch power
2	1.25 Y/G	RR power window switch down signal
3		NC
4	1.25 Y/O	RR power window switch down signal
5	1.25 Y/P	RR power window switch up signal
6	1.25 Y/B	RR power window switch up signal

Harness Connector View

Door Harness Connector(D--)

RR Door Locking Connector

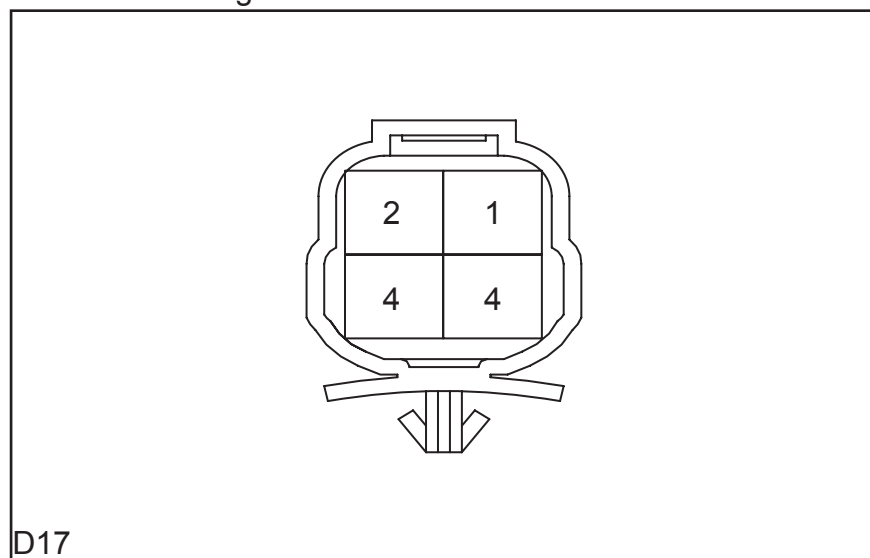

D17

D17 Pin Definition

Pin Number	Wire Width / Color	Function
1	0.50 Br/Y	Lock signal
2	0.50 Br/W	Unlock signal
3		NC
4		NC

RR Speaker Connector

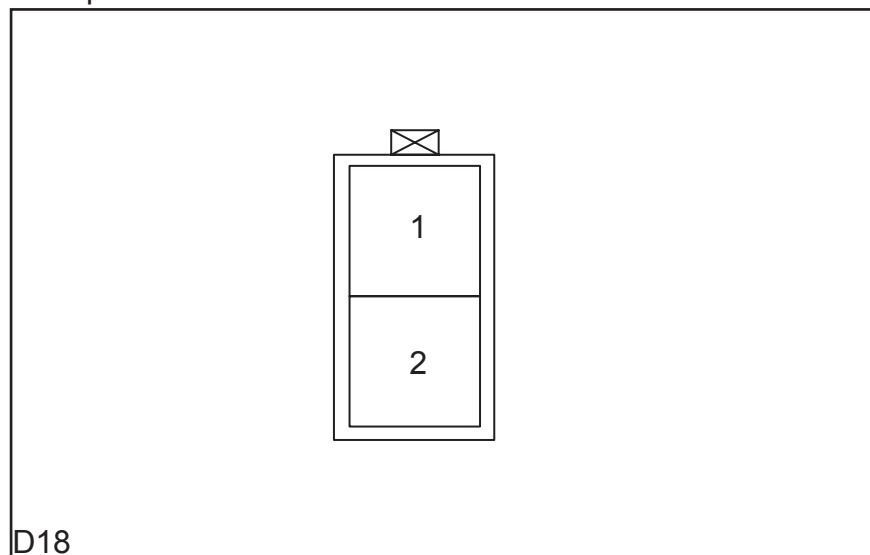

D18

D18 Pin Definition

Pin Number	Wire Width / Color	Function
1	0.50 V/Y	Speaker +
2	0.50 V/O	Speaker -

Door Harness Connector(D--)

LF Door Antenna Connector

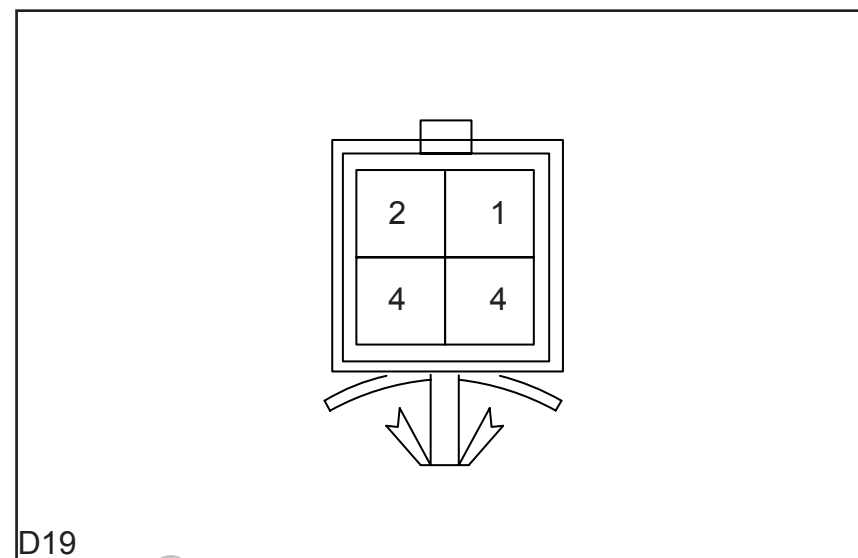

D19

D19 Pin Definition

Pin Number	Wire Width / Color	Function
1	0.50 Br/W	Antenna signal -
2	0.50 Br/R	Antenna signal +
3	0.50 Br/Y	LF door Locking signal
4	0.50 Br/G	LF door Locking signal

LR Door Harness to Body Harness Connector

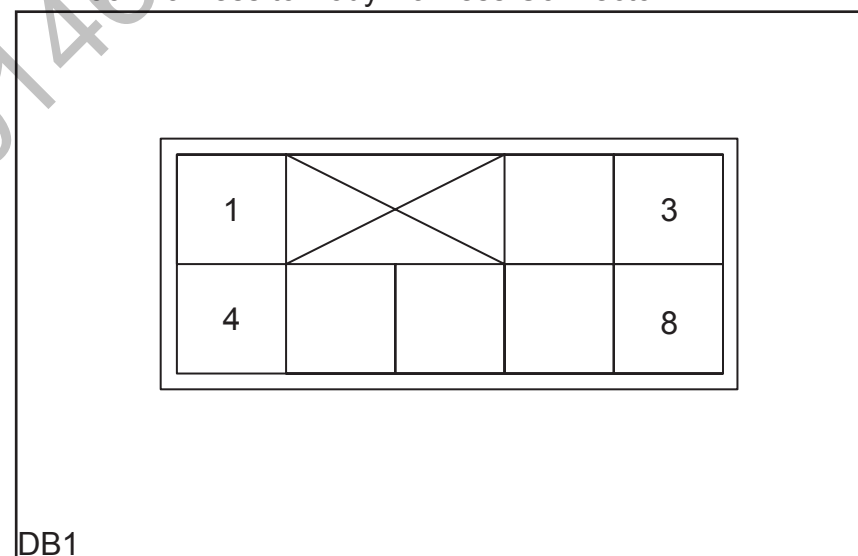

DB1

DB1 Pin Definition

Pin Number	Wire Width / Color	Function
1	1.25 Y/V	LR power window switch down signal
2	1.25 Y/Br	LR power window switch up signal
3	0.50 Br/W	Unlock signal
4	0.50 Br/Y	Lock signal
5	1.25 Y/R	LR power window switch power
6	0.50 V/G	LR speaker power +
7	0.50 V/BI	LR speaker power -
8		NC

Harness Connector View

Door Harness Connector(D--)

RR Door Harness to Body Harness Connector

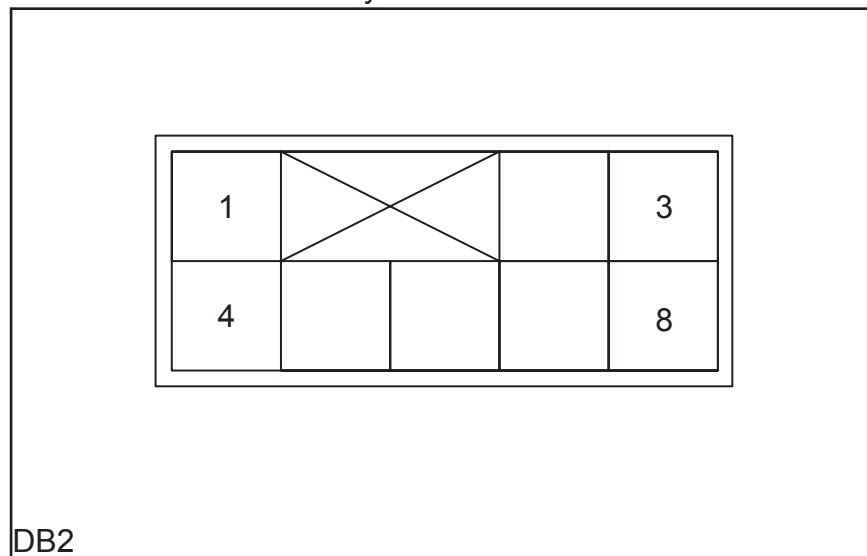

DB2

DB2 Pin Definition

Pin Number	Wire Width / Color	Function
1	1.25 Y/G	RR power window switch down signal
2	1.25 Y/B	RR power window switch up signal
3	0.50 Br/W	Unlock signal
4	0.50 Br/Y	Lock signa
5	1.25 Y/R	RR power window switch power
6	0.50 V/Y	RR speaker power +
7	0.50 V/O	RR speaker power -
8		NC

Door Harness Connector(D--)

LF Door Harness to IP Harness Connector

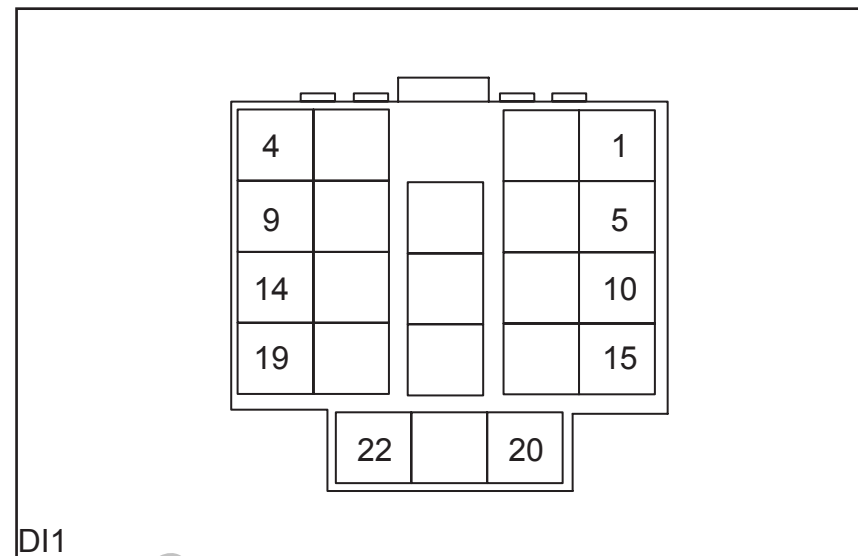

DI1

DI1 Pin Definition

Pin Number	Wire Width / Color	Function
1	0.50 V/W	LF door speaker +
2	0.50 V/B	LF door speaker -
3	0.50 P	Left outside rearview heating power
4	0.50 B	Ground
5	0.50 Y/Br	Left outside rearview left/right power
6	0.50 Y/G	Left outside rearview up/down power
7	2.00 B	Ground
8	0.50 Y/W	Left outside rearview up/down or left/right adjustment
9	1.25 Y/Bl	RF door power window up powe
10	1.25 Y/G	RF door power window down power
11	1.25 Y/Br	LR door power window up
12	2.00 Y	LF door power window switch power
13	1.25 Y/V	LR door power window down
14	1.25 Y/O	RR door power window up signal
15	1.25 Y/P	RR door power window down signal
16	0.50 G/W	Left side turn lamp power
17	1.25 Y/R	RR power window switch power
18	0.50 Br	LF door lock status switch signal
19	0.50 Br/Y	Lock signal
20	0.50 Br/W	Unlock signal
21		NC
22		NC

Harness Connector View

Door Harness Connector(D--)

LF Door Harness to IP Harness Connector

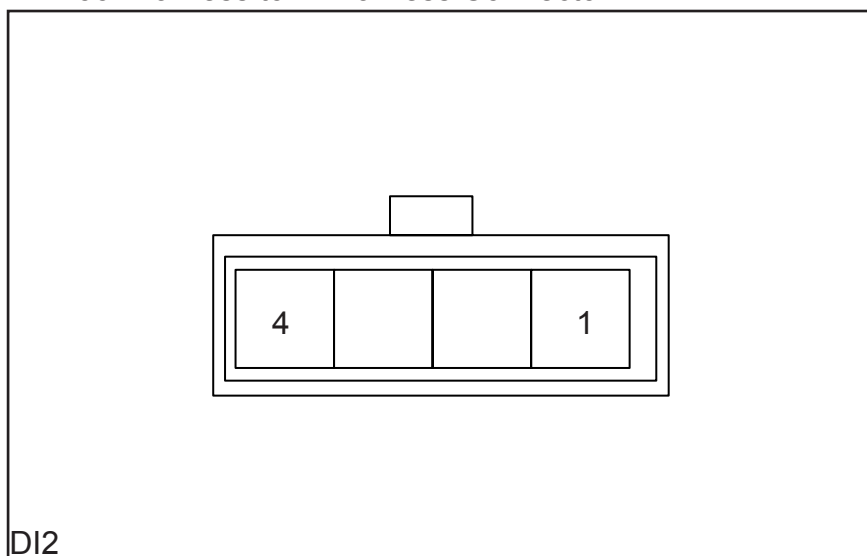

DI2 Pin Definition

Pin Number	Wire Width / Color	Function
1	0.50 Br/R	LF door antenna signal +
2	0.50 Br/W	LF door antenna signal -
3	0.50 Br/Y	LF door Locking signal
4	0.50 Br/G	LF door Locking signal

Door Harness Connector(D--)

RF Door Harness to IP Harness Connector

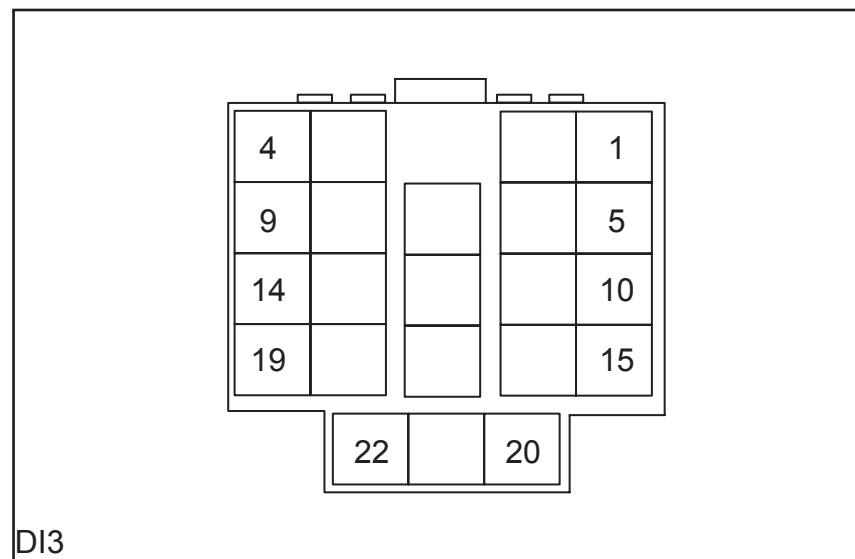

DI3

DI3 Pin Definition

Pin Number	Wire Width / Color	Function
1	0.50 V/Br	Speaker -
2	0.50 V/Gr	Speaker +
3	0.50 P	Left side rearview heating power
4	0.50 B	Ground
5	0.50 G/Y	Right side turn lamp power
6	1.25 Y/Bl	Right outside rearview up/down power
7	1.25 Y/R	RF power window switch down power
8	0.50 Y/W	Right front power window switch down signal
9	0.50 Br/W	Unlock signal
10	0.50 Br/Y	Lock signal
11	0.50 Y/Gr	Right outside rearview left/right power
12	1.25 Y/G	RF power window switch down signal
13		NC
14		NC
15		NC
16		NC
17	0.50 Y/Bl	Right outside rearview turn left/right power
18		NC
19		NC
20		NC
21		NC
22		NC

Harness Connector View

Roof Harness Connector(R--)

Front Dome Lamp Connector

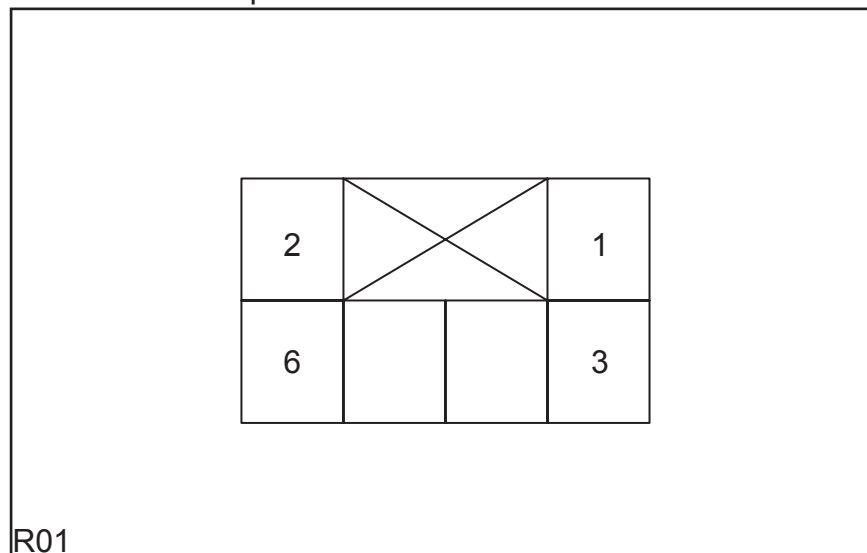

R01

R01 Pin Definition

Pin Number	Wire Width / Color	Function
1	0.50 G/V	Power
2	0.50 G/B	Sunroof switch signal
3	0.50 B	Ground
4	0.50 Gr	Sunroof switch signal
5	0.50 G	Sunroof switch signal
6	0.50 Gr/B	Instrument Cluster singal

Rear Dome Lamp Connector

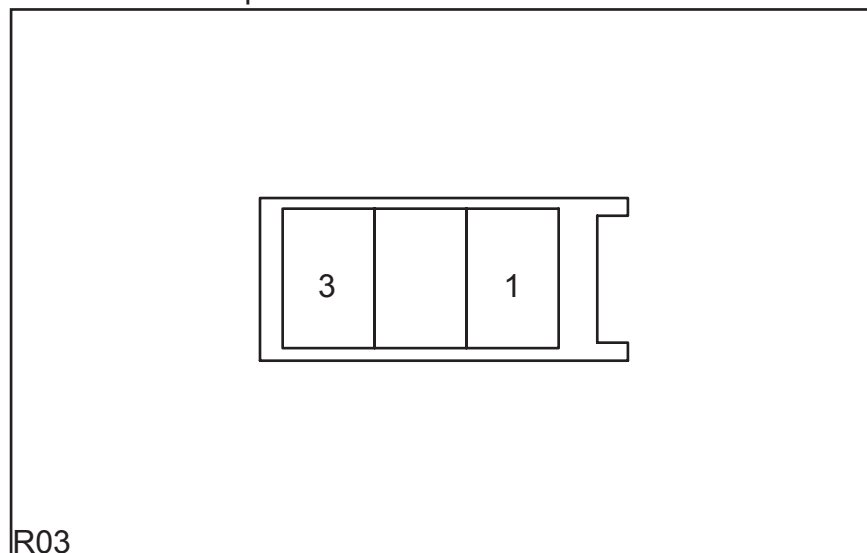

R03

R03 Pin Definition

Pin Number	Wire Width / Color	Function
1	0.50 Gr/B	Instrument Cluster signal
2	0.50 G/V	Power
3	0.50 B	Ground

Roof Harness Connector(R--)

Sunroof Connector

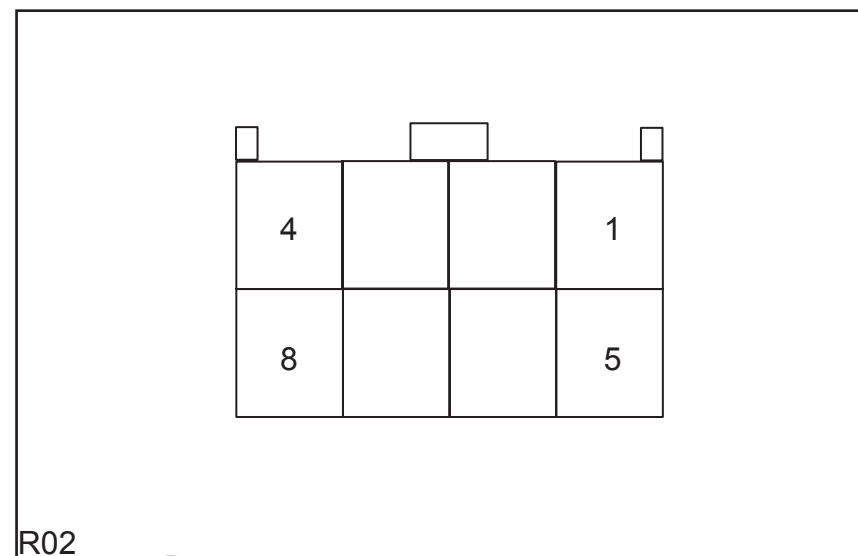

R02

R02 Pin Definition

Pin Number	Wire Width / Color	Function
1	0.50 G/B	Sunroof switch signal
2	2.00 B	Ground
3	0.50 Y	Power
4		NC
5	0.50 G	Sunroof switch signal
6	2.00 R	Power
7		NC
8	0.50 Gr	Sunroof switch signal

Harness Connector View

Roof Harness Connector(R--)

Roof Harness to IP Harness Connector

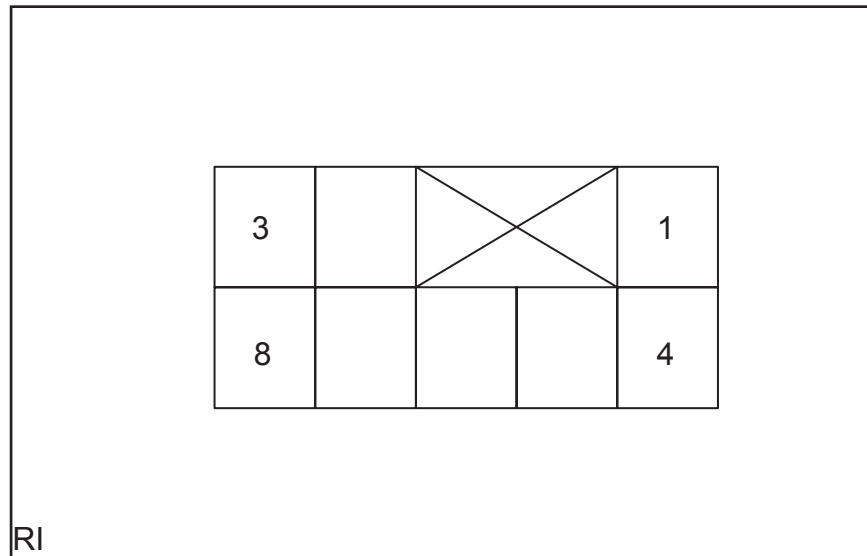

RI Pin Definition

Pin Number	Wire Width / Color	Function
1	0.50 G/V	Power
2	0.50 Gr/B	Instrument Cluster singal
3	0.50 Y	Power
4	2.00 R	Power
5	2.00 B	Ground
6	0.50 B	Ground
7		NC
8		NC

Roof Harness Connector(R--)

MachineSoft.IR
09120146259

Harness Connector View

SRS Harness Connector(S--)

SRS ECU Connector

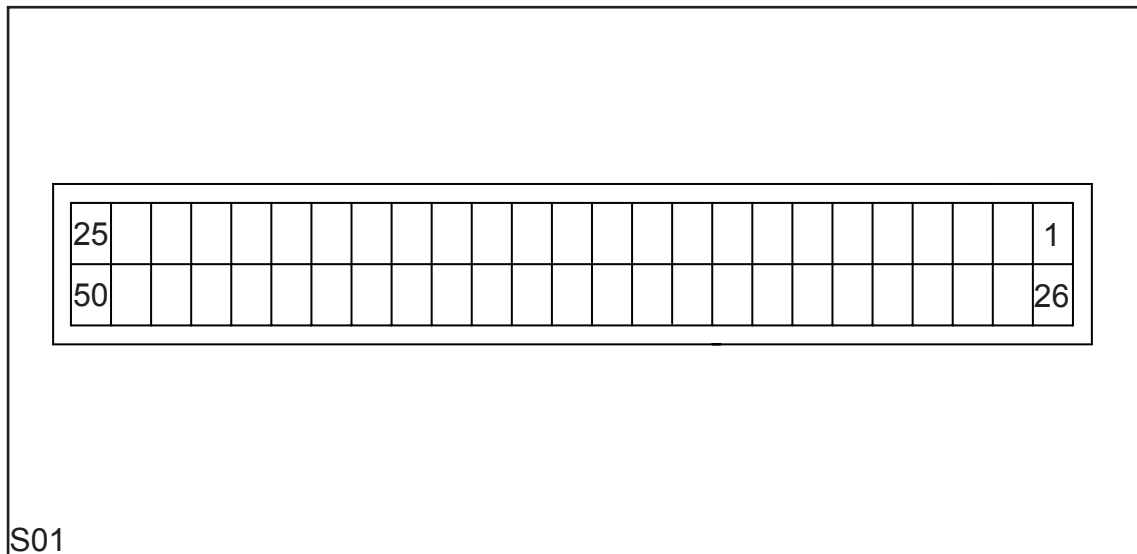

S01 Pin Definition

Pin Number	Wire Width / Color	Function
1	0.50 Y/V	RF colision sensor signal
2	0.50 Y/Br	LF colision sensor signal
3	0.50 Y/R	Right side colision sensor signal
4	0.50 Y	Left side colision sensor signal
5	0.50 V/Br	LR door gas curtain signal
6	0.50 V/Y	LR door gas curtain signal
7	0.50 V/G	RF door gas curtain signal
8	0.50 V/W	RF door gas curtain signal
9	0.50 V/R	LF door gas curtain signal
10	0.50 O/B	LF door gas curtain signal
11		NC
12	0.50 O/Y	Passenger side airbag signal
13	0.50 O/G	Passenger side airbag signal
14		NC
15	0.50 O/R	Driver side airbag signal
16	0.50 O/W	Driver side airbag signal
17	0.50 W/R	K-line
18		NC
19	0.50 G	Air bag indicator
20	0.50 B	Ground
21	0.85 R	IG1 Power
22	0.50 O/Gr	Passenger side pre-safety belt signal
23	0.50 O/V	Passenger side pre-safety belt signal
24	0.50 O/BI	Driver side pre-safety belt signal
25	0.50 O/Br	Driver side pre-safety belt signal
26	0.50 Y/Gr	RF colision sensor signal
27	0.50 Y/BI	LF colision sensor signal
28	0.50 Y/G	Right side colision signal
29	0.50 Y/W	Left side colision signal

SRS Harness Connector(S--)

Pin Number	Wire Width / Color	Function
30	0.50 V/BI	RR door gas curtain signal
31	0.50 V/Gr	RR door gas curtain signal
32		NC
33		NC
34		NC
35		NC
36		NC
37		NC
38		NC
39	0.50 G/Y	Colision signal
40		NC
41		NC
42		NC
43		NC
44		NC
45		NC
46		NC
47		NC
48		NC
49		NC
50		NC

Driver Side SRS Model Connector

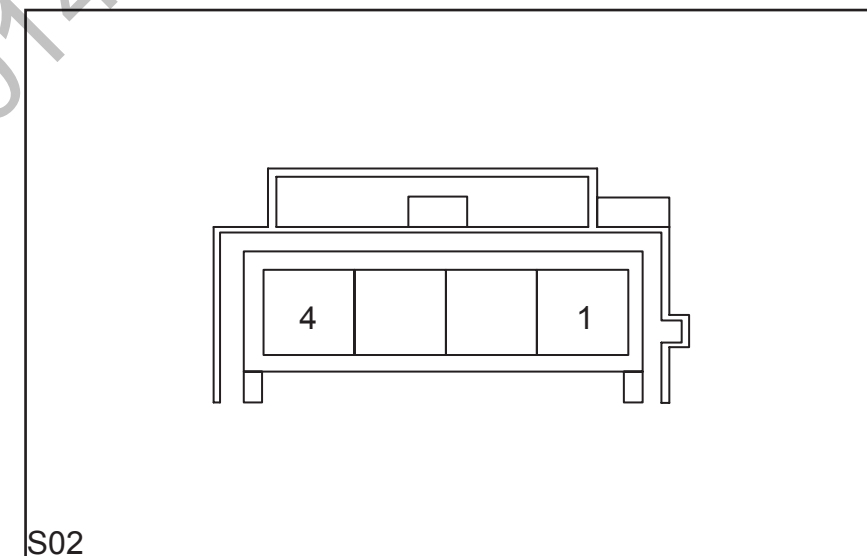

S02 Pin Definition

Pin Number	Wire Width / Color	Function
1		NC
2		NC
3	0.50 O/R	Signal -
4	0.50 O/W	Signal +

Harness Connector View

SRS Harness Connector(S--)

Passenger Side SRS Model Connector

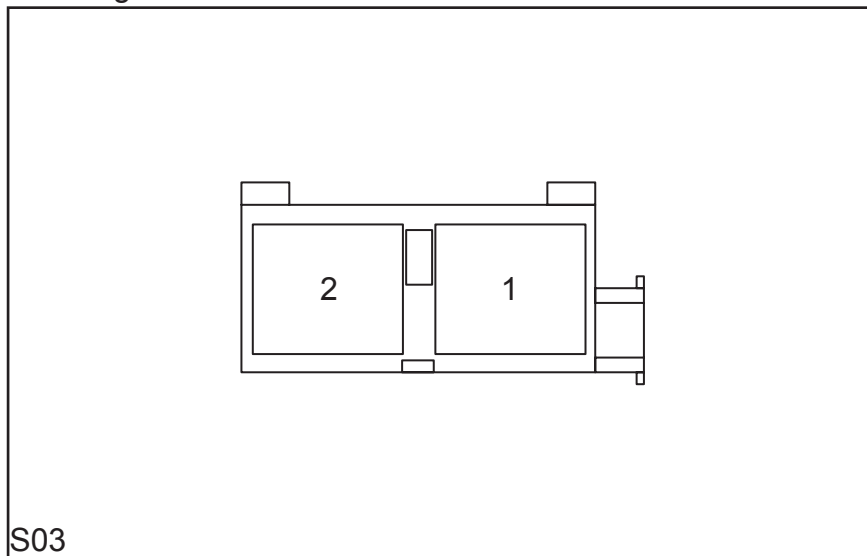

S03 Pin Definition

Pin Number	Wire Width / Color	Function
1	0.50 O/Y	Signal -
2	0.50 O/G	Signal +

Passenger Seat Belt Wirning Connector

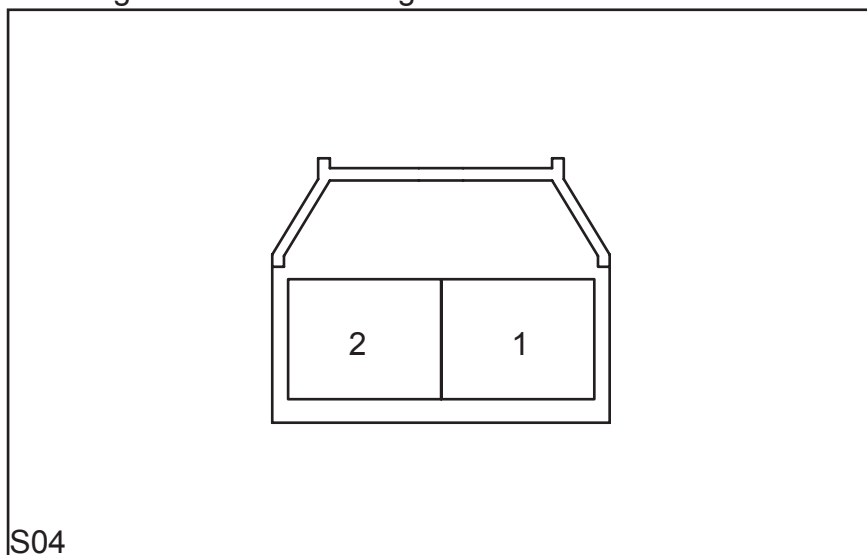

S04 Pin Definition

Pin Number	Wire Width / Color	Function
1	0.50 O/V	Signal +
2	0.50 O/Gr	Signal -

SRS Harness Connector(S--)

RF Colision Sensor Connector

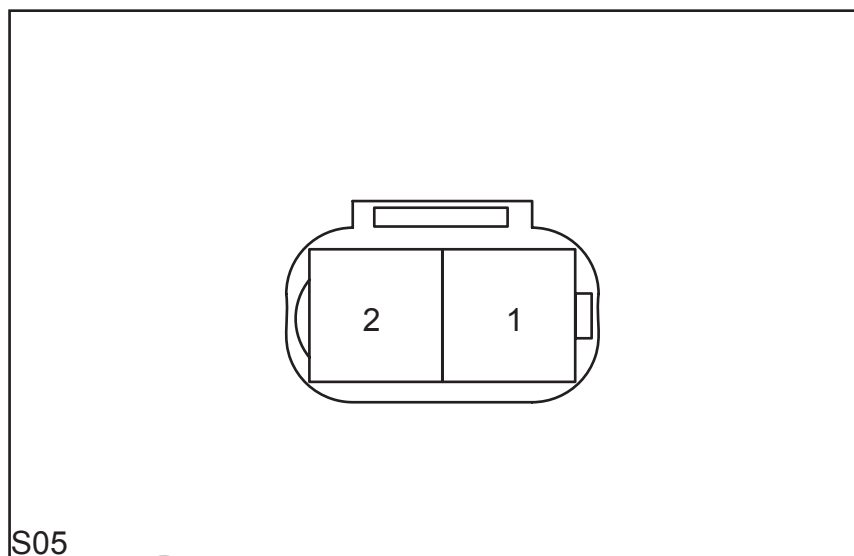

S05 Pin Definition

Pin Number	Wire Width / Color	Function
1	0.50 Y/R	Signal +
2	0.50 Y/G	Signal -

RR Door Gas Curtain Connector

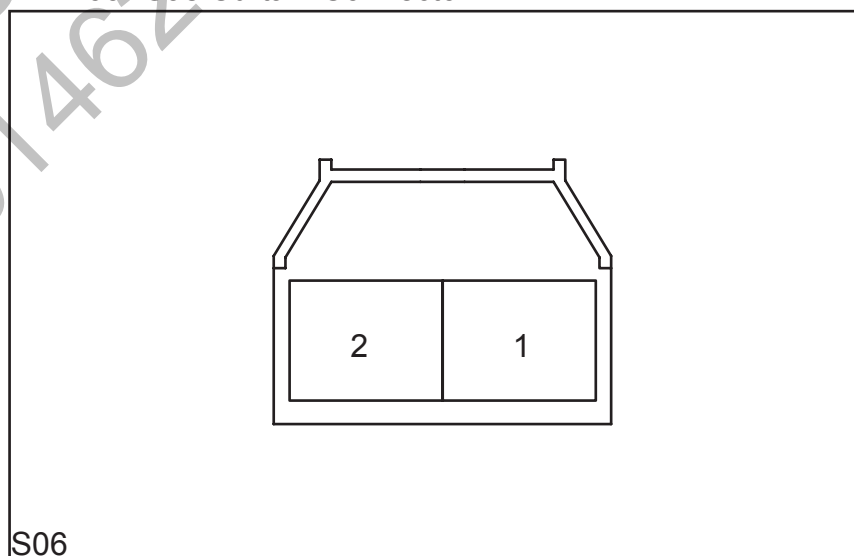

S06 Pin Definition

Pin Number	Wire Width / Color	Function
1	0.50 V/Bl	Signal -
2	0.50 V/Gr	Signal +

Harness Connector View

SRS Harness Connector(S--)

RF Door Gas Curtain Connector

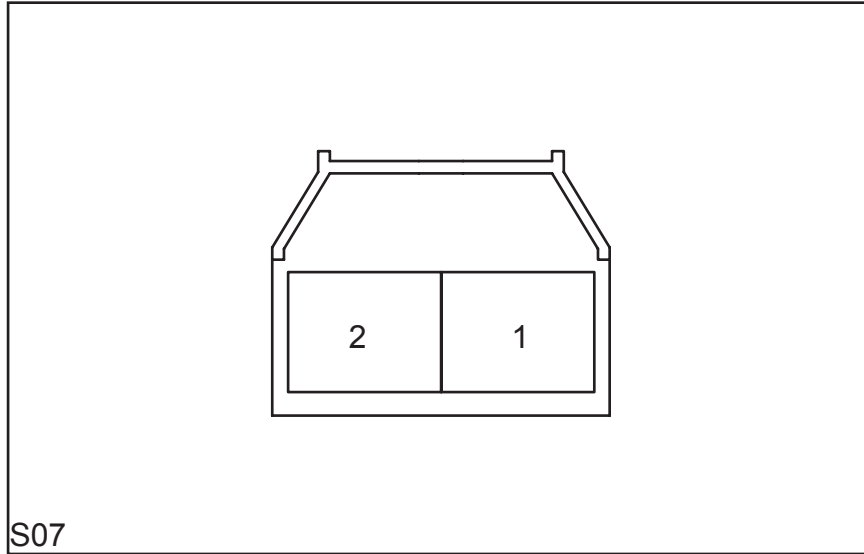

S07

S07 Pin Definition

Pin Number	Wire Width / Color	Function
1	0.50 V/W	Signal +
2	0.50 V/G	Signal -

SRS Harness Connector(S--)

Driver Seat Belt Wirning Connector

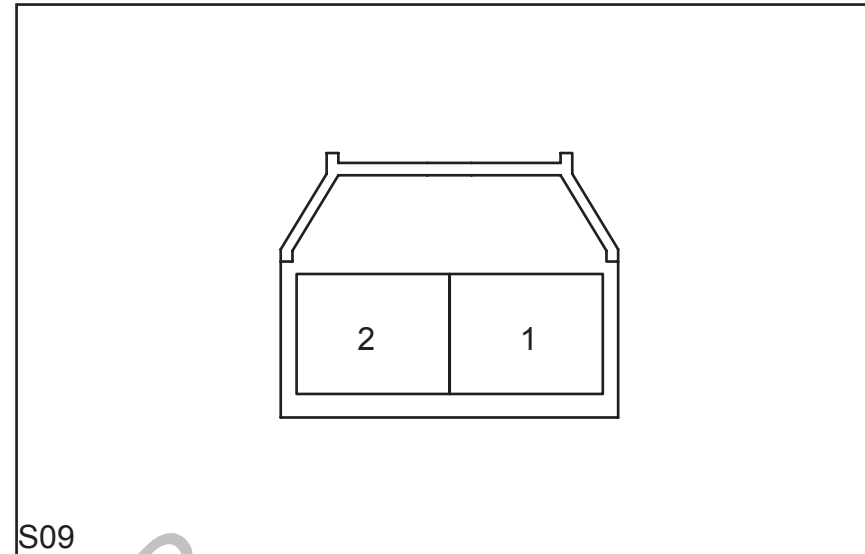

S09

S09 Pin Definition

Pin Number	Wire Width / Color	Function
1	0.50 O/Br	Signal +
2	0.50 O/Bl	Signal -

LF Door Gas Curtain Connector

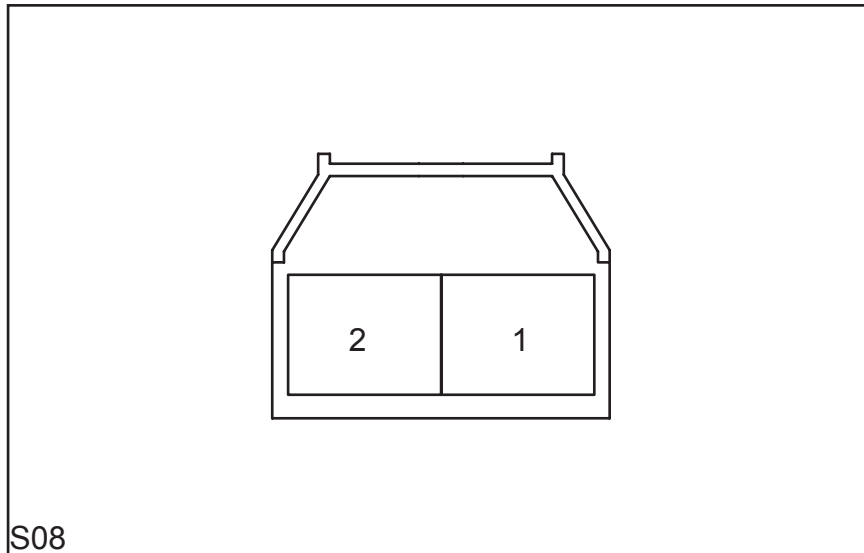

S08

S08 Pin Definition

Pin Number	Wire Width / Color	Function
1	0.50 O/B	Signal +
2	0.50 V/R	Signal -

LF Colision Sensor Connector

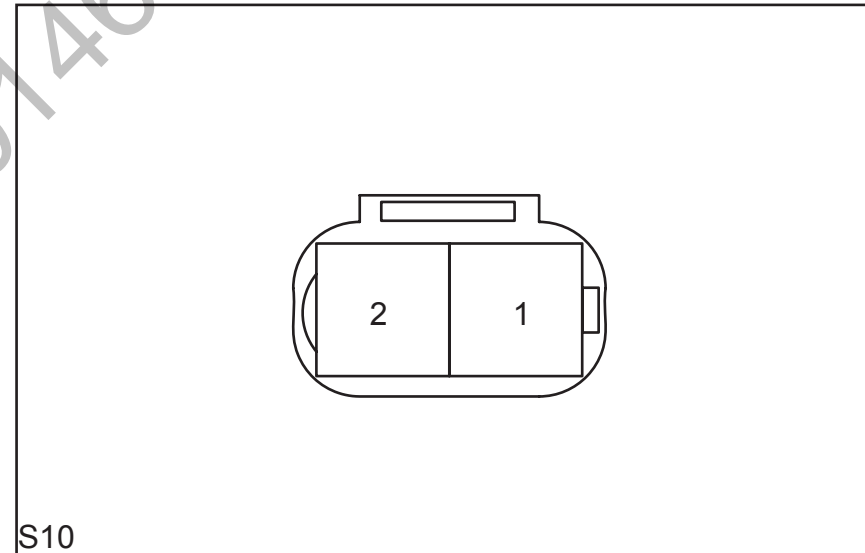

S10

S10 Pin Definition

Pin Number	Wire Width / Color	Function
1	0.50 Y	Signal +
2	0.50 Y/W	Signal -

Harness Connector View

SRS Harness Connector(R--)

LR Door Gas Curtain Connector

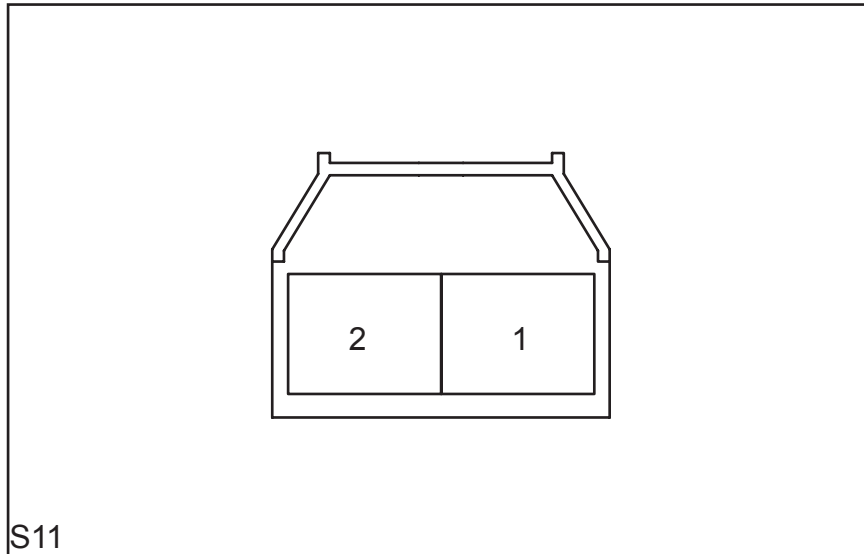

S11 Pin Definition

Pin Number	Wire Width / Color	Function
1	0.50 V/Y	Signal +
2	0.50 V/Br	Signal -

SRS Harness Connector(S--)

SRS Harness to IP Harness Connector

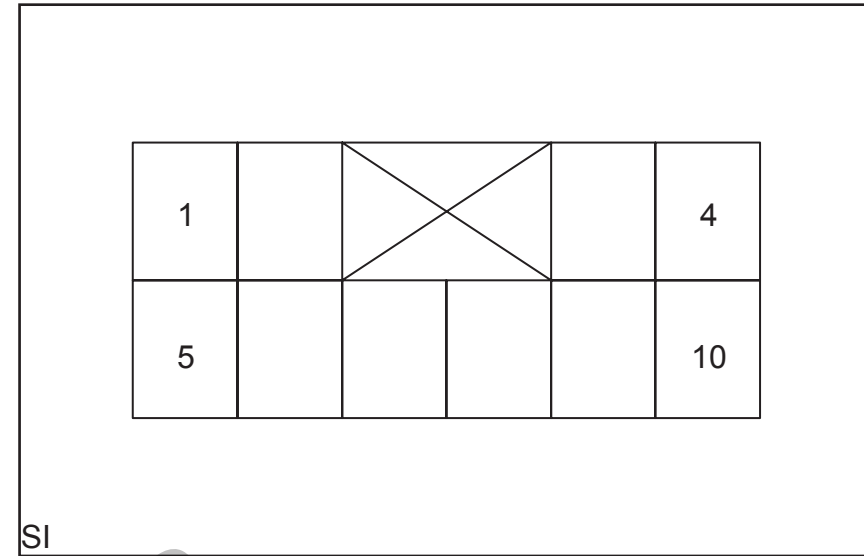

SI Pin Definition

Pin Number	Wire Width / Color	Function
1	0.50 Y/V	RF colision sensor +
2	0.50 Y/Gr	RF colision sensor -
3	0.50 Y/Br	LF colision sensor +
4	0.50 Y/Bl	LF colision sensor -
5	0.85 R	Power
6	0.50 G	Air bag indicator
7	0.50 W/R	K-line
8	0.50 G/Y	Colision signal
9		NC
10		NC

Harness Connector View

Rear Bumper Harness Connector(M--)

Reverse Radar Connector

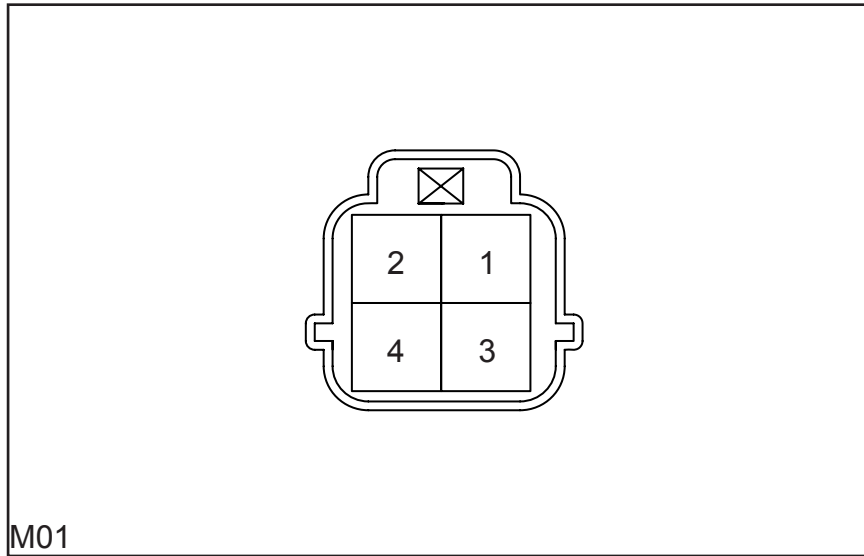

M01 Pin Definition

Pin Number	Wire Width / Color	Function
1	0.50 W/B	Reverse radar ground
2	0.50 Gr/R	Reverse radar signal
3		NC
4	0.50 R/Y	Reverse radar signal power

Rear Bumper Harness Connector(M--)

RR License Lamp Connector

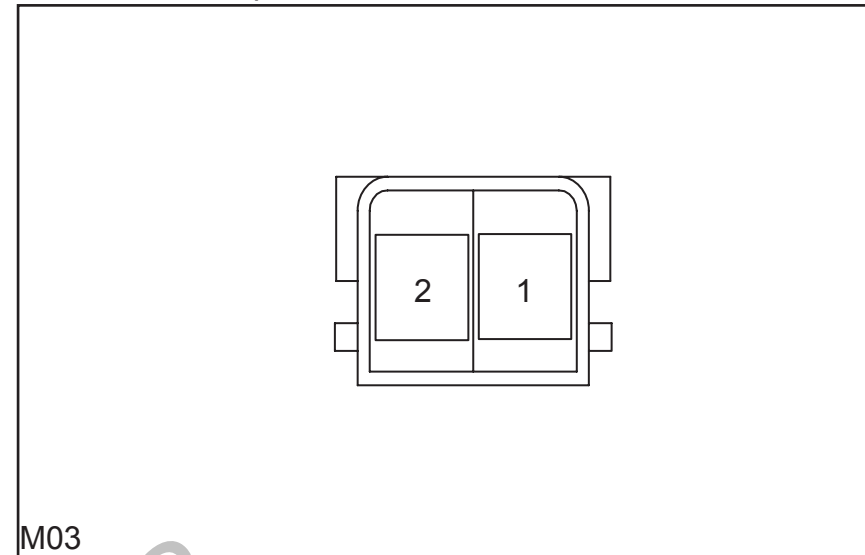

M03 Pin Definition

Pin Number	Wire Width / Color	Function
1	0.50 BI	Power
2	0.50 B	Ground

LR License Lamp Connector

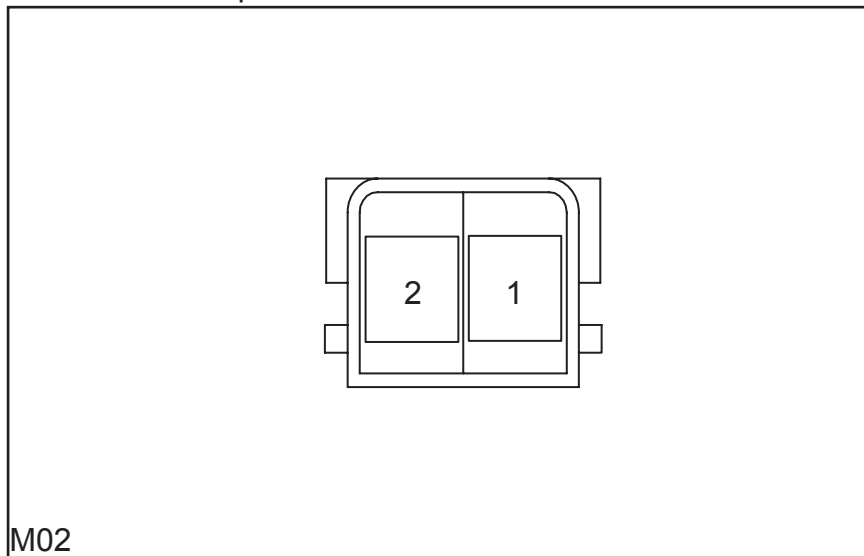

M02 Pin Definition

Pin Number	Wire Width / Color	Function
1	0.50 BI	Power
2	0.50 B	Ground

Reverse Radar Connector

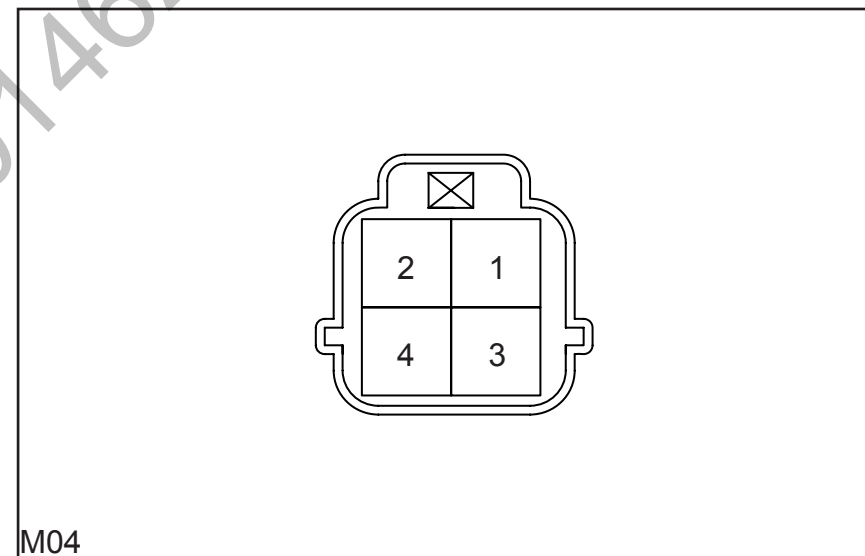

M04 Pin Definition

Pin Number	Wire Width / Color	Function
1	0.50 W/B	Reverse radar ground
2	0.50 Gr/W	Reverse radar signal
3		NC
4	0.50 R/Y	Reverse radar signal power

Harness Connector View

Rear Bumper Harness Connector(M--)

LR Fog Lamp Connector

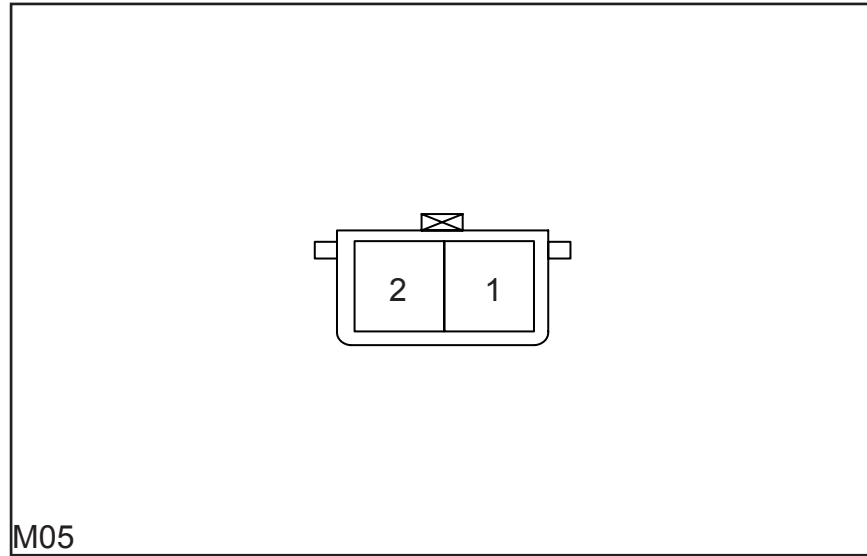

M05

M05 Pin Definition

Pin Number	Wire Width / Color	Function
1	0.50 G/Br	Power
2	0.50 B	Ground

RR Fog Lamp Connector

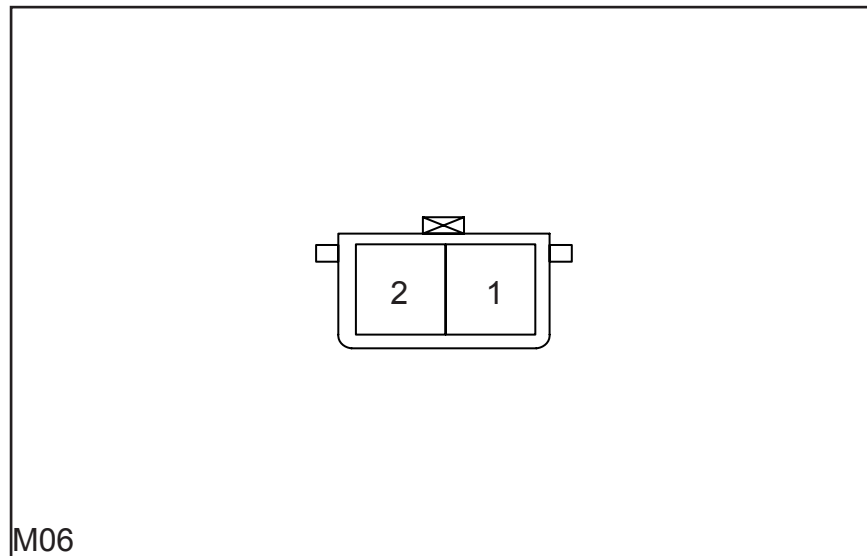

M06

M06 Pin Definition

Pin Number	Wire Width / Color	Function
1	0.50 G/Br	Power
2	0.50 B	Ground

Rear Bumper Harness Connector(M--)

Rear Bumper Antenna Connector

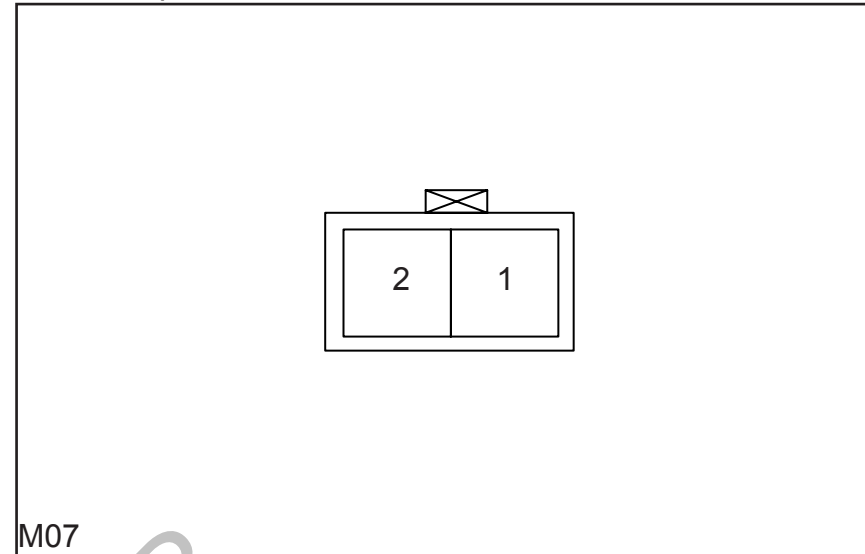

M07

M07 Pin Definition

Pin Number	Wire Width / Color	Function
1	0.50 Br/B	Signal -
2	0.50 Bl/Br	Signal +

Rear Camera Connector

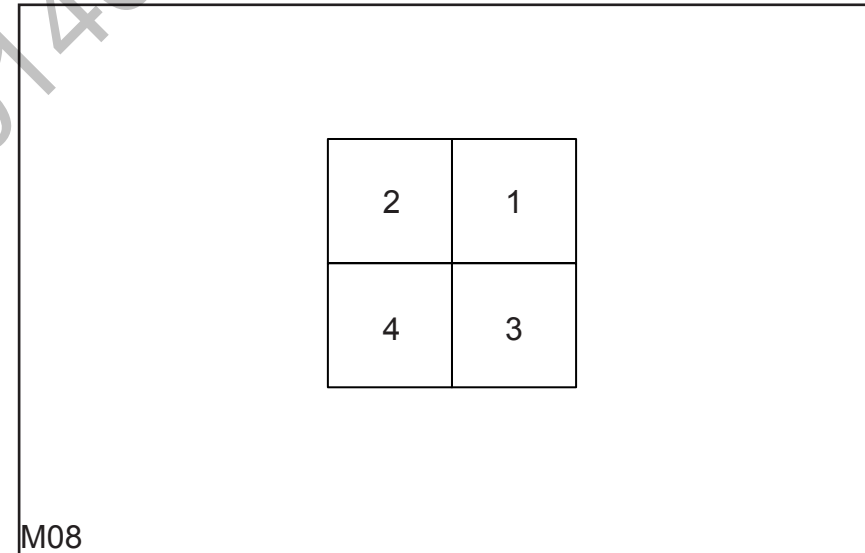

M08

M08 Pin Definition

Pin Number	Wire Width / Color	Function
1	0.50 W	Signal -
2	0.50 B	Signal +
3	0.50 G	Power-
4	0.50 R	Power+

Harness Connector View

Rear Bumper Harness Connector(M--)

Rear Bumper Harness to Body Harness Connector

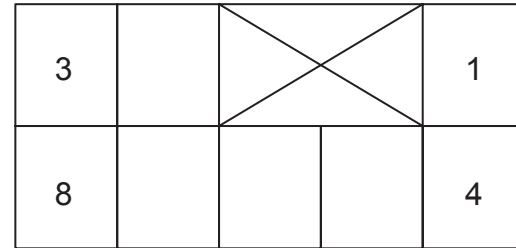

MB1

MB1 Pin Definition

Pin Number	Wire Width / Color	Function
1	0.50 R/Y	Reverse redar signal power
2	0.50 Gr/R	Reverse redar signal (left)
3	0.50 Gr/W	Reverse redar signal (right)
4	0.50 BI	Background lamp power
5	0.50 B	Ground
6	0.50 W/B	Reverse redar signal ground
7	0.50 G/Br	Rear fog lamp power
8	0.50 B	Ground

Rear Bumper Harness Connector(M--)

Rear Bumper Harness to Body Harness Connector

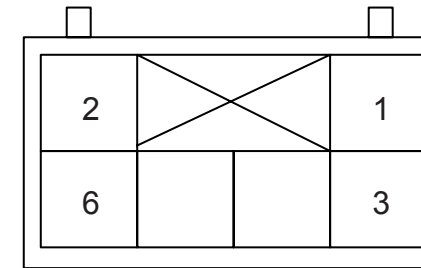

MB2

MB2 Pin Definition

Pin Number	Wire Width / Color	Function
1	0.50 BI/Br	Rear Bumper Antenna signal +
2	0.50 Br/B	Rear Bumper Antenna signal -
3	0.50 B	signal -
4	0.50 W	signal +
5	0.50 G	Power-
6	0.50 R	Power+

Harness Connector View

Air Conditioning Harness Connector(A--)

A/C Control Padel Connector

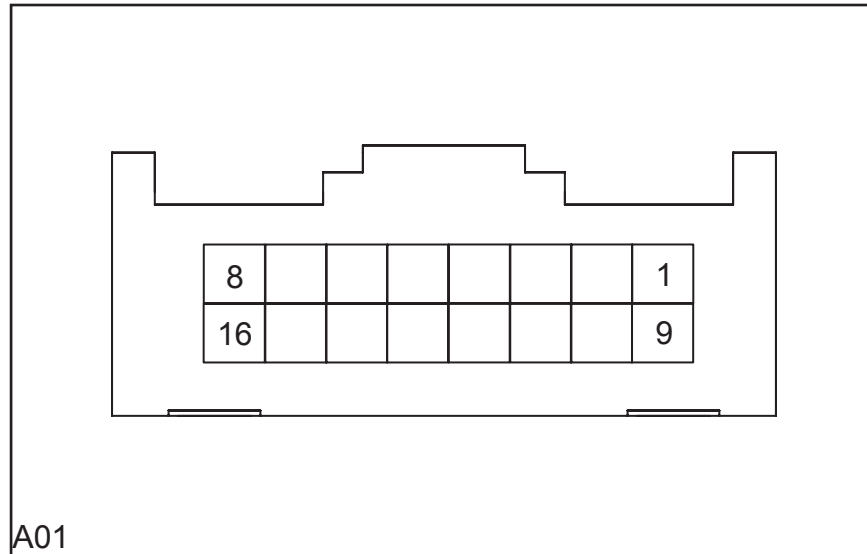

A01 Pin Definition

Pin Number	Wire Width / Color	Function
1		NC
2		NC
3	0.50 Gr/G	In-outside circulation motor signal
4	0.50 Gr/Y	Evaporation temprature sensor signal
5	0.50 Gr/R	Air fixing motor signal
6	0.50 R/B	Air fixing motor signal
7	0.50 BI/W	Model motor signal
8	0.50 B/W	A/C compressor control
9		NC
10		NC
11	0.50 Gr/BI	Blower resistor signal
12	0.50 W/B	Blower resistor signal
13		NC
14		NC
15		NC
16	0.50 W/R	IG2 power

Air Conditioning Harness Connector(A--)

A/C Control Padel Connector

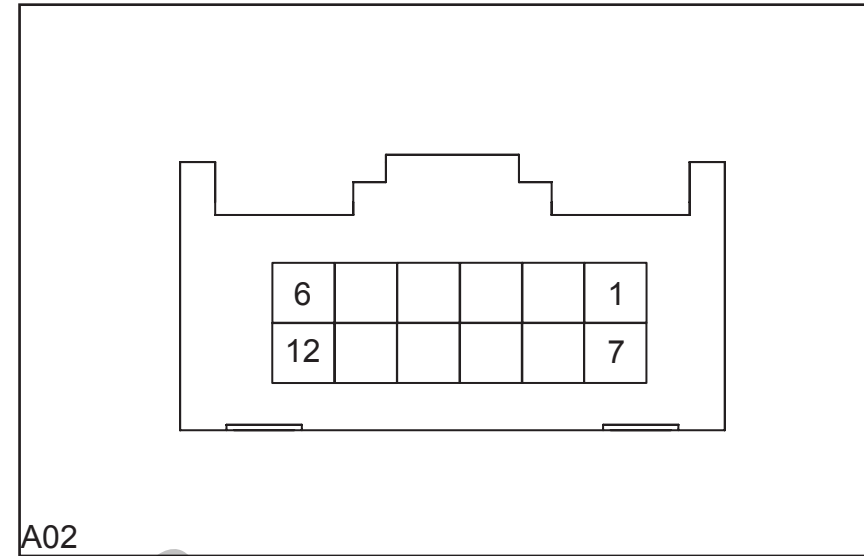

A02 Pin Definition

Pin Number	Wire Width / Color	Function
1		NC
2	0.50 Y	In-outside circulation motor signal
3	0.50 Br	Air fixing motor signal
4	0.50 R/G	Air fixing motor signal
5	0.50 R/Y	Background lamp
6		NC
7	0.50 Br/W	Model motor signal
8	0.50 Br/R	Model motor signal
9	0.50 BI/Y	Defrost heating control
10		NC
11	0.50 B	Ground
12	0.50 R/BI	In-outside circulation motor signal

Harness Connector View

Air Conditioning Harness Connector(A--)

Bolwer Adjusting Model Connector

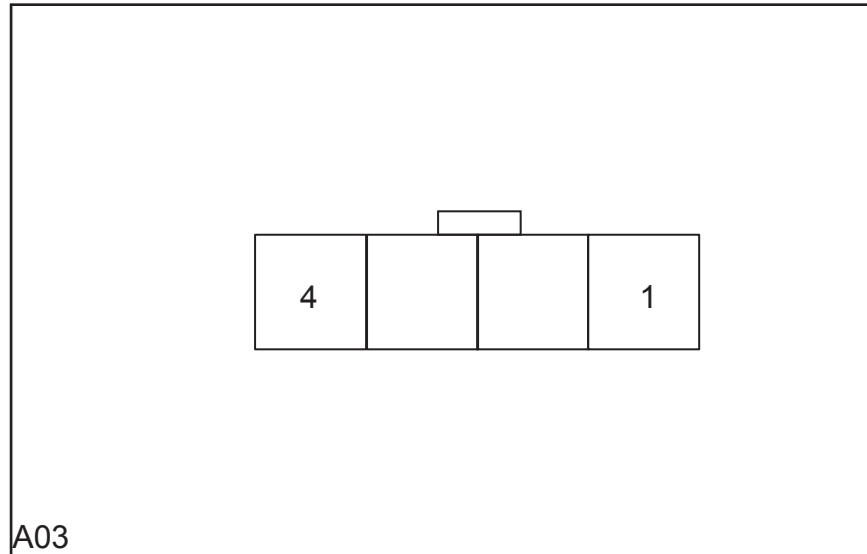

A03

A03 Pin Definition

Pin Number	Wire Width / Color	Function
1	3.00 W/Y	Power
2	0.50 W/B	Blower resistor signal
3	0.50 Gr/Bl	Blower resistor signal
4	3.00 B	Ground

Evaporator Temperature Sensor Connector

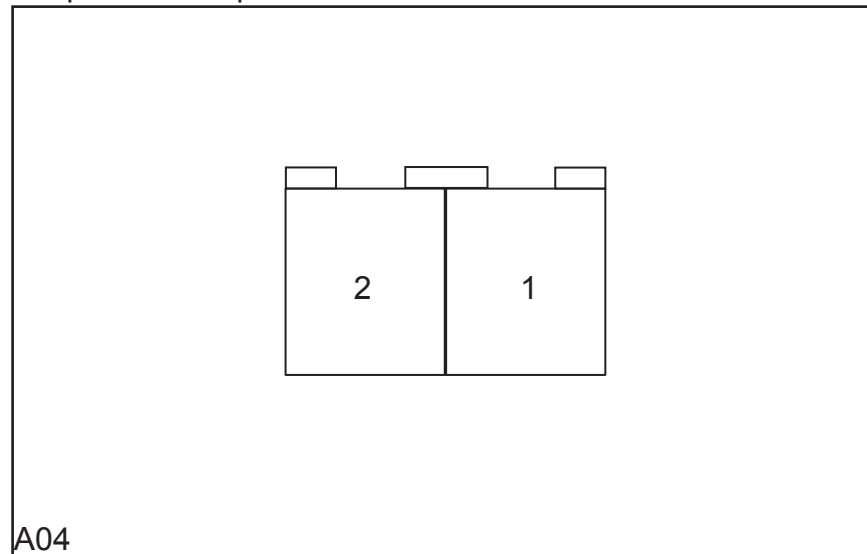

A04

A04 Pin Definition

Pin Number	Wire Width / Color	Function
1	0.50 Gr/Y	Evaporation temprature sensor signal
2	0.50 B	Ground

Air Conditioning Harness Connector(A--)

Bolwer Connector

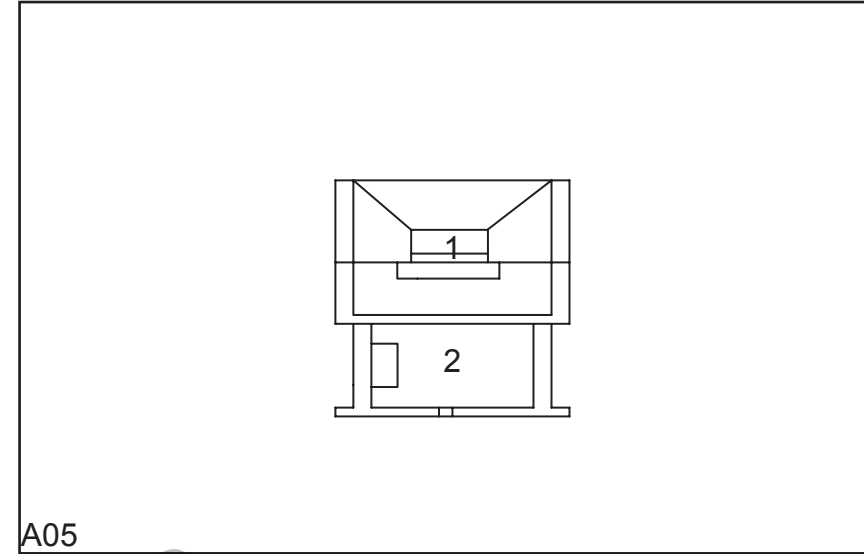

A05

A05 Pin Definition

Pin Number	Wire Width / Color	Function
1	3.00 R	Power
2	3.00 W/Y	Ground

Inside and Outside Circulation Motor Connector

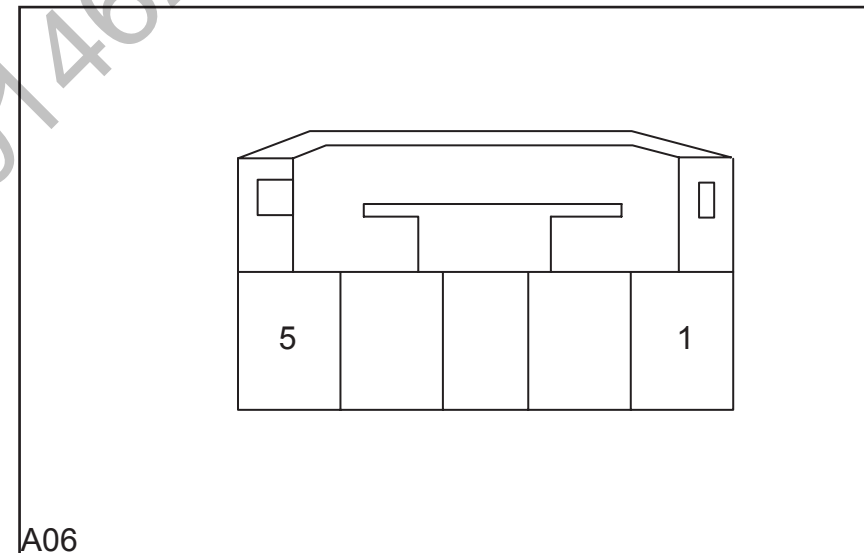

A06

A06 Pin Definition

Pin Number	Wire Width / Color	Function
1	0.50 R/Bl	In-outside circulation motor signal
2	0.50 Gr/G	In-outside circulation motor signal
3		NC
4		NC
5	0.50 Y	In-outside circulation motor signal

Harness Connector View

Air Conditioning Harness Connector(A--)

Air Fixing Motor Connector

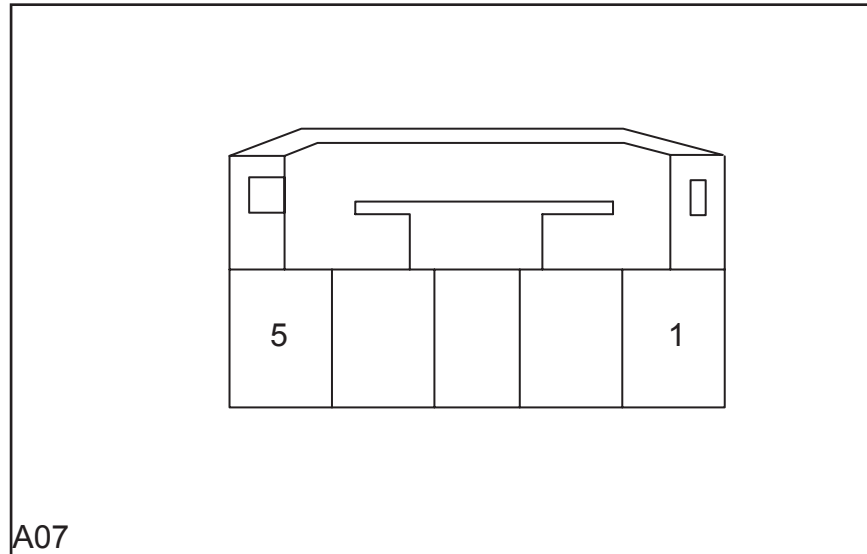

A07 Pin Definition

Pin Number	Wire Width / Color	Function
1	0.50 Br	Air fixing motor signal
2	0.50 R/G	Air fixing motor signal
3	0.50 R/B	Air fixing motor signal
4	0.50 B	Ground
5	0.50 Gr/R	Air fixing motor signal

Model Motor Connector

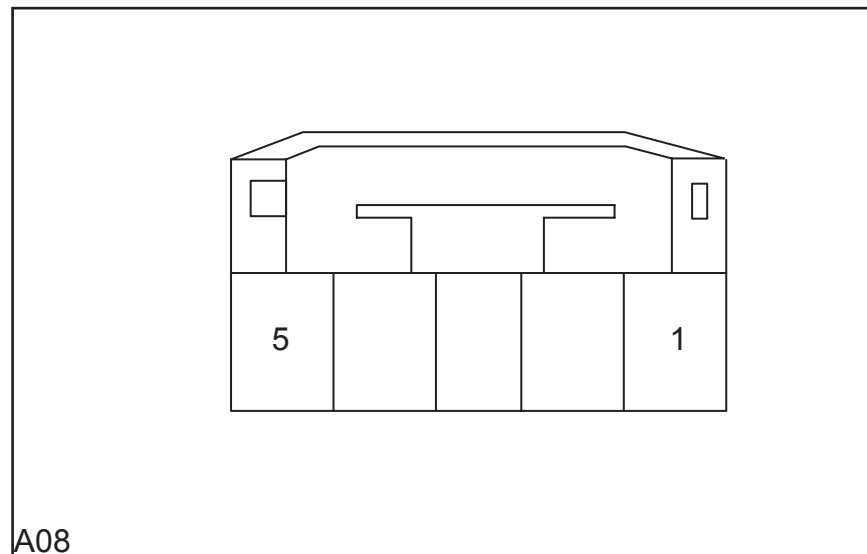

A08 Pin Definition

Pin Number	Wire Width / Color	Function
1	0.50 Br/W	Model motor signal
2	0.50 Br/R	Model motor signal
3	0.50 Bl/W	Model motor signal
4	0.50 Gr/R	Model motor signal
5	0.50 B	Ground

Air Conditioning Harness Connector(A--)

Air Conditioning Harness to IP Harness Connector

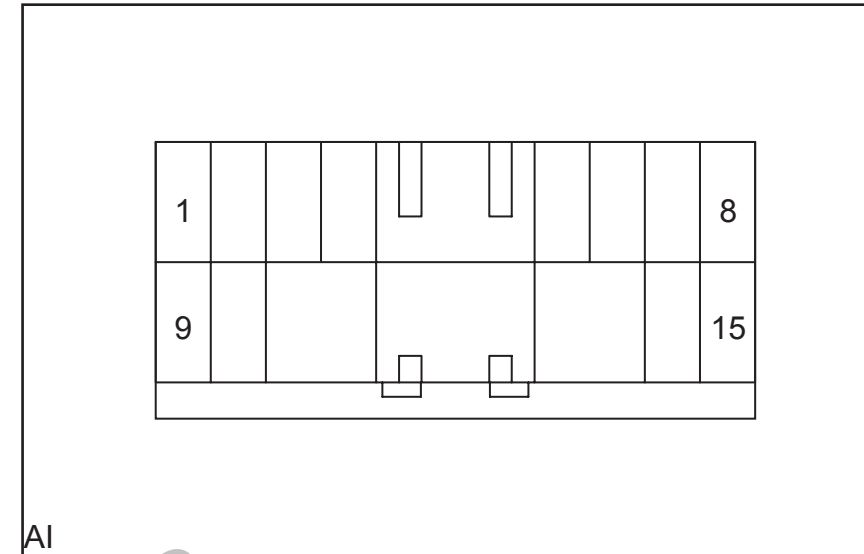

AI Pin Definition

Pin Number	Wire Width / Color	Function
1	0.50 W/R	IG2 power
2	0.50 R/Y	Background lamp power
3	0.50 Bl/Y	Defrosting control
4		NC
5	0.50 B	Signal ground
6	0.50 B/W	A/C control
7		NC
8		NC
9		NC
10		NC
11	3.00 R	Blower power
12	3.00 B	Regulator module ground
13		NC
14		NC
15		NC

Abbreviations

Abbreviations	Description
A/C	Air Conditioning
AAT	Ambient Air Temperature
ABS	Anti-lock Brake System
AM/FM	Amplitude Modulation/ Frequency Modulation
APP	Accelerator Pedal Position
ASR	Acceleration Slip Regulation
AT	Automatic Transmission
ATF	Automatic Transmission Fluid
BCM	Body Control Module
CAN	Controller Area Network
CD	Compact Disc
CKP	Crankshaft Position Sensor
CMP	Camshaft Position Sensor
CRK	Crank
DDM	Driver Door Module
DLC	Data Link Connector
DOHC	Double Overhead Camshaft
DTC	Diagnostic Trouble Code
DVD	Digital Video Disk
EBD	Electronic Brakeforce Distribution
ECM	Engine Control Module
ECT	Engine Coolant Temperature
EGR	Exhaust-Gas Recirculation
EOBD	European On Board Diagnostic
ESP	Electronic Stability Program
ETC	Electronic Tune Control
EVAP	Evaporative Emission Control System
FWD	Front Wheel Drive
GPS	Global Positioning System
GVM	Gross Vehicle Mass
HCU	Hydraulic Control Unit
HFM	Hands Free Module
HID	High Intensity Discharge
HO ₂ S	Heated Oxygen Sensor
HVAC	Heating, Ventilation and Air Conditioning
I/P	Instrument Panel
IAC	Idle Air Control Valve
IAT	Intake Air Temperature
ICU	Integrated Control Unit
IPC	Instrument Panel Cluster
ISO	International Standards Organization
ISS	Input Shaft Speed
KS	Knock Sensor
LED	Light Emitting Diode
LF	Left Front

LIN	Local Interconnect Network
LR	Left Rear
MAF	Mass Air Flow
MAP	Manifold Absolute Pressure
MIL	Malfunction Indicator Lamp
MP3	MPEG Audio Layer 3
MT	Manual Transmission
MTC	Manual Temperature Control
MY	Model Year
OBD-II	On Board Diagnostic II
OEM	Original Equipment Manufacturer
PAM	Parking Aid Module
PCV	Positive Crankcase Ventilation
PDC	Power Distribution Center
PDM	Passenger Door Module
PEPS	Passive Entry Passive Start
PIN	Personal Identification Number
PWM	Pulse Width Modulation
RF	Right Front
RR	Right Rear
RKE	Remote Keyless Entry
SAE	Society of Automotive Engineers
SAS	Steering Angle Sensor
SCCM	Steering Column Control Module
SDM	Supplemental Diagnostic Module
SFI	Sequential Fuel Injection
SOHC	Single Overhead Camshaft
SRI	Service Reminder Indicator
SRR	Supplemental Restraint System
TCC	Torque Converter Clutch
TCM	Transmission Control Module
TIR	Total Indicator Reading
TPMS	Tire Pressure Monitoring System
TPS	Throttle Position Switch
TRS	Transmission Range Sensor
TSB	Technical Service Bulletin
TWC	Three-way Catalyst
VFD	Vacuum Fluorescent Display
VIN	Vehicle Identification Number
VSS	Vehicle Speed Sensor
WSS	Wheel Speed Sensor

 **Note:** Refer to the workshop manual for the abbreviations not covered by the list.



MachineSoft.IR
09120146259

-  No.1539, Jinkai Avenue, NNZ, Chongqing, China.
-  [Http://www.lifanmotors.net](http://www.lifanmotors.net)
-  iecauto03@lifan.com
-  +00862361668042/00862361668043