

pride

RHD. LHD

WIRING DIAGRAM

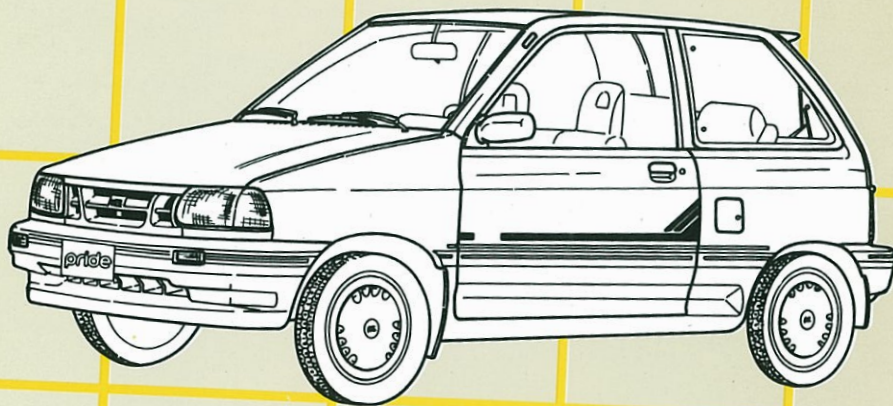

91-04

1991 Kia Motors Corporation



pride

Wiring Diagram (Right and Left Hand Drive)

FOREWORD

This wiring diagram incorporates the wiring schematic for the basic vehicle and its available optional equipment. Actual vehicle wiring may vary slightly depending upon optional equipment and/or local specifications. All information contained in this booklet is based on the latest information available at the time of printing. Kia Motors Corporation reserves the right to make changes without previous notice.

This information, photographs, drawings and specifications contained in this manual were in effect the time of printing. So, it is recommended that this manual should be kept up-to-date by insertion of new information.

Kia Motors Corporation
SEOUL, KOREA

SECTION INDEX

Name	Section
<ul style="list-style-type: none"> ■ HOW TO USE THIS WIRING DIAGRAM ■ SYMBOLS IN THIS WIRING DIAGRAM 	O
<ul style="list-style-type: none"> ■ PARTS INDEX 	PI
<ul style="list-style-type: none"> ■ ELECTRICAL WIRING SCHEMATIC 	W
<ul style="list-style-type: none"> ■ STARTING SYSTEM ■ CHARGING SYSTEM 	A
<ul style="list-style-type: none"> ■ IGNITION SYSTEM ■ COOLING FAN SYSTEM 	B
<ul style="list-style-type: none"> ■ METERS & WARNING LIGHTS 	C
<ul style="list-style-type: none"> ■ FRONT WIPER & WASHER ■ REAR WIPER & WASHER 	D
<ul style="list-style-type: none"> ■ HEADLIGHTS ■ TAIL LIGHTS ■ FRONT SIDE LIGHTS ■ LICENSE LIGHTS ■ ILLUMINATION LIGHTS 	E
<ul style="list-style-type: none"> ■ TURN & HAZARD FLASHER LIGHTS ■ REVERSE LIGHTS 	F
<ul style="list-style-type: none"> ■ HEATER 	G
<ul style="list-style-type: none"> ■ CLOCK ■ INTERIOR LIGHTS ■ LUGGAGE COMPARTMENT LIGHT 	H
<ul style="list-style-type: none"> ■ REAR WINDOW DEFROSTER ■ CIGARETTE LIGHTER 	I
<ul style="list-style-type: none"> ■ HORN ■ STOP LIGHTS 	J
<ul style="list-style-type: none"> ■ JOINT CONNECTOR & GROUND CIRCUIT 	JC
<ul style="list-style-type: none"> ■ COMMON CONNECTOR LIST 	X

HOW TO USE THIS WIRING DIAGRAM

The complete electrical system is divided into charging system, ignition system, etc.

Each system is shown on both right and left pages as described below.

When reading the wiring diagram, the following should be noted:

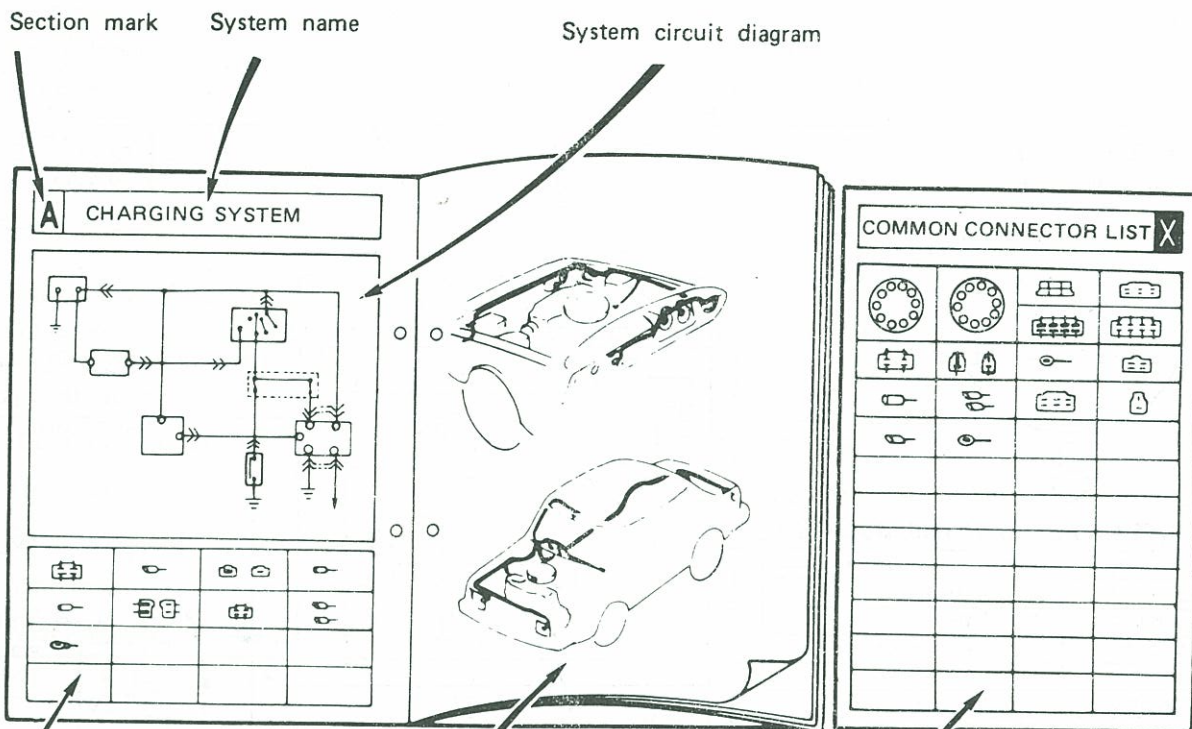

- Connector diagram identifies the exclusive applicable connectors for the circuit.

- Right page illustrates the actual location of each connector and the routing diagram of the harness.

- The last page, "Section X", illustrates common connectors related to each system.

CONNECTOR

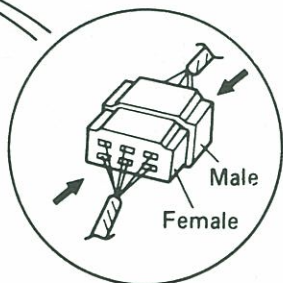
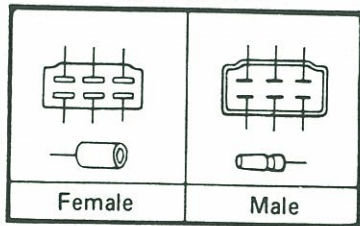

Way to look at Connector

HOW TO USE THIS WIRING DIAGRAM

WIRING COLOR CODE

Wiring color code is indicated with alphabetical letter(s). The first letter indicates the basic color of the wire, and second letter (if any) indicates the color of the stripe.

CODE	COLOR	CODE	COLOR
B	Black	Lg	Light green
Br	Brown	O	Orange
G	Green	R	Red
L	Blue	Y	Yellow
Lb	Light blue	W	White
Lo	Blue orange	Wr	White red

The same fusible link and fuses are indicated on each page.

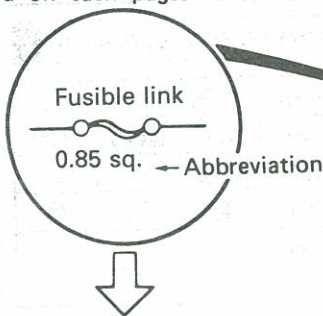

ABBREVIATIONS USED IN THIS BOOKLET

Abbr.	Term	Abbr.	Term
St	Start	A	Ampere
IG	Ignition	W	Watt
ACC	Accessory	R	Resistance
AS	Auto stop	Tr	Transistor
INT	Intermittent	M	Motor
Lo	Low	SW	Switch
Mi	Middle	Sq	Square per millimeter
Hi	High		
R.H.	Right hand	A/T	Automatic transmission
L.H.	Left hand		
F.R	Front right	M/T	Manual transmission
F.L	Front left		
R.R	Rear right	NO	Normal opened
R.L	Rear left	NC	Normal closed
V	Volt		

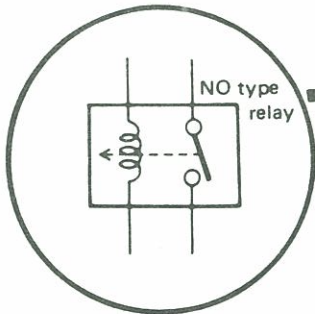

The relays and switches are identified as NC (normal closed), or NO (normal opened), to indicate their normal position when they are not in operation.

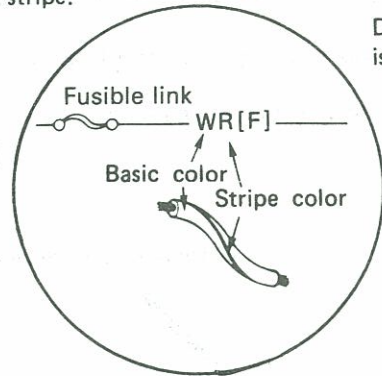

Direction of current is shown by the arrow

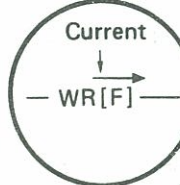

CONNECTOR

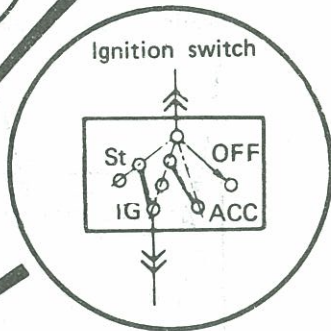
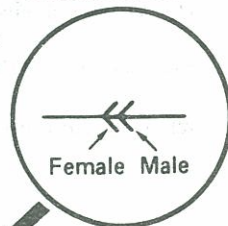

Circuit is shown with the ignition switch off.

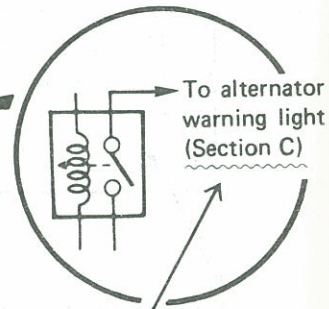
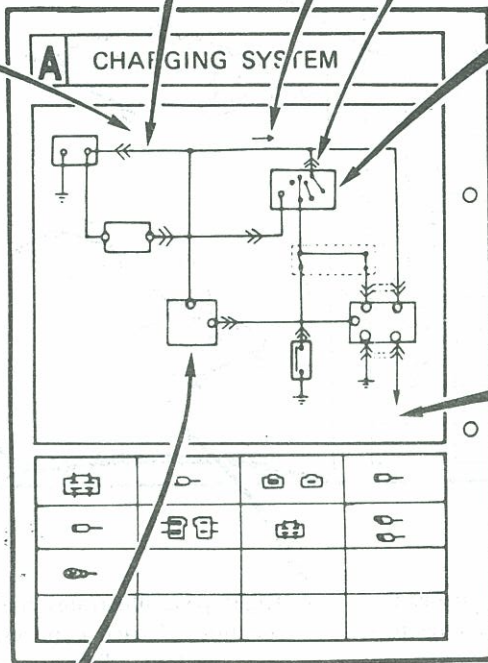

Legend in the parenthesis () indicates the reference section.

	Relay		Switch	
	NO type relay	NC type relay	NO switch	NC switch
Not in operation				
	Stop	Flow	Stop	Flow
In operation				
	Flow	Stop	Flow	Stop

SYMBOLS IN THIS WIRING DIAGRAM

EXAMPLE OF CIRCUIT DIAGRAM

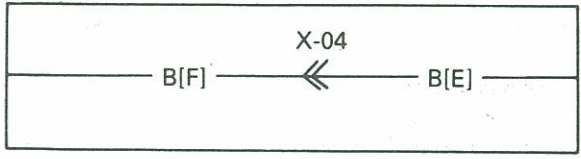

- * It is seen from the above that the male-side black line of the X-04 shows the engine harness and the female-side black line shows the front harness.
- * It is seen from the above that the X-04 connector is a connector connecting the engine and the front.

EXMPL E OF CONNECTOR

C-03 Fuel Tank Unit [R]

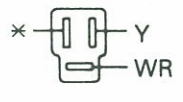

- * This sign (*) means "empty" – Not used.
- * It is seen from the above that this connector (C-03) is on the rear harness.

HARNESS SYMBOLS

Each harness is distinguished by a symbol to indicate to which harness belong a wiring and connectors in the circuit diagrams and connector charts.

DESCRIPTION OF HARNESS	SYMBOL	DESCRIPTION OF HARNESS	SYMBOL
Front Harness	[F]	No. 2 Rear Harness	[R2]
Engine Harness	[E]	Interior Light Harness	[In]
Instrument Panel Harness	[I]		
Rear Harness	[R]		

GRAPHIC SYMBOLS

Battery	Ground	Fuse	Fusible link	Motor
Coil solenoid	Resistance	Variable resistance	Thermistor	Diode
Condenser	Transistor	Pump	Lamp	Horn
Speaker	Cigar lighter	Heater	Illuminated Diode	Zener Diode

Parts Name	Section	Parts Name	Section
A Alternator With Regulator	A	Illumination Lights	
B Battery	A~J	Meter	C
Blower Motor	G	Intermittent Wiper Relay Unit	D
Blower Motor Control Switch	G	Interior Light	H
Brake Fluid Level Sensor	C	Indicator & Warning Lights	
C Carburetor		Brake	C
Air Vent Solenoid Valve	B	Charge	C
Slow Fuel Cut Solenoid Valve	B	High Beam	C
Cigar Lighter	I	Oil Pressure	C
Clock	H	Rear Window Defroster	C
Cluster Switch		Turn L.H., R.H.	C
Rear Window Defroster Switch	I	L License Light	E
Rear Wiper & Washer Switch	D	Luggage Compartment Light	H
Combination Meter	C	Luggage Compartment Light Switch	H
Combination Switch		O Oil Pressure Switch	C
Horn Switch	J	P Parking Brake Switch	C
Light Switch	E, F	R Rear Combination Light	
Turn & Hazard Switch	F	Reverse Light	F
Front Wiper & Washer Switch	D	Tail Light	E
Condenser	B	Turn & Hazard Flasher Light	F
Cooling Fan Motor	B	Stop Light	J
Cooling Fan Relay	B	Rear Washer Motor	D
D Distributor	B	Rear Window Defroster	I
Door Switch	H	Rear Window Defroster Cord	I
F Flasher Unit	F	Rear Window Defroster Switch	I
Front Side Light	E	Rear Wiper Motor	D
Front Side Turn Light	F	Rear Wiper & Washer Switch	
Front Turn Light	F	Resistor	G
Front Washer Motor	D	Reverse Light Switch	F
Front Wiper Motor	D	S Spark Plug	B
Fuel Meter	C	Starting Motor	A
Fuel Tank Unit	C	Stop Light Switch	J
Fusible Link	A~J	T Tachometer	C
H Headlight	E	Temp. Meter	C
Horn	J	W Water Temp. Sensor	C
Horn Relay	J	Water Temp. Switch	B
I Igniter	B	Water Thermo Switch	B
Ignition Coil	B		
Ignition Switch	A~D, F~I		

ELECTRICAL WIRING SCHEMATIC

Note:
 ——— Current from Battery
 - - - - Current from IG Terminal of Ignition Switch
 · · · · Current from ACC Terminal of Ignition Switch
 ——— Others

W

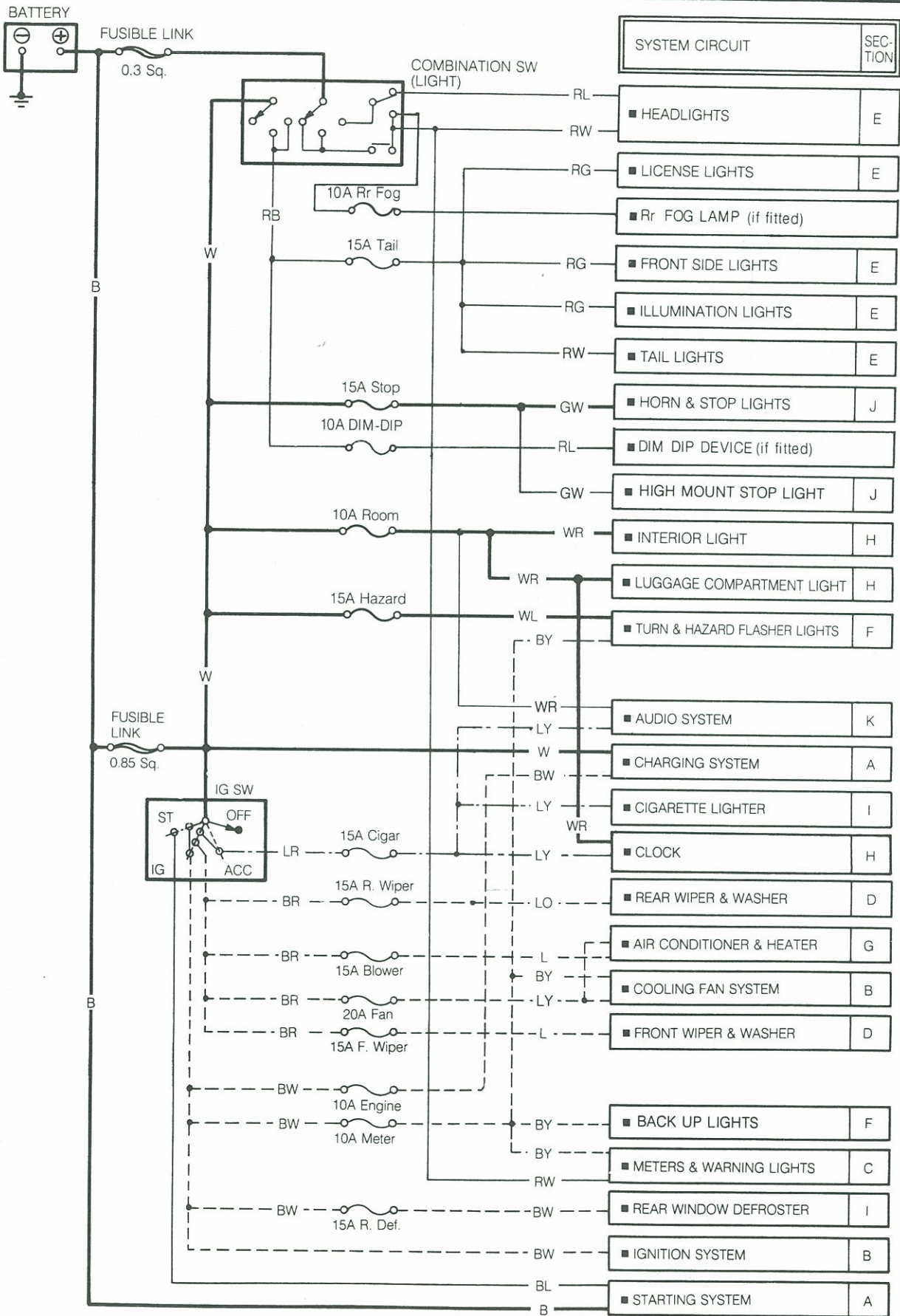

SYSTEM CIRCUIT	SECTION
HEADLIGHTS	E
LICENSE LIGHTS	E
Rr FOG LAMP (if fitted)	
FRONT SIDE LIGHTS	E
ILLUMINATION LIGHTS	E
TAIL LIGHTS	E
HORN & STOP LIGHTS	J
DIM DIP DEVICE (if fitted)	
HIGH MOUNT STOP LIGHT	J
INTERIOR LIGHT	H
LUGGAGE COMPARTMENT LIGHT	H
TURN & HAZARD FLASHER LIGHTS	F
AUDIO SYSTEM	K
CHARGING SYSTEM	A
CIGARETTE LIGHTER	I
CLOCK	H
REAR WIPER & WASHER	D
AIR CONDITIONER & HEATER	G
COOLING FAN SYSTEM	B
FRONT WIPER & WASHER	D
BACK UP LIGHTS	F
METERS & WARNING LIGHTS	C
REAR WINDOW DEFROSTER	I
IGNITION SYSTEM	B
STARTING SYSTEM	A

A

■ CHARGING SYSTEM ■ STARTING SYSTEM

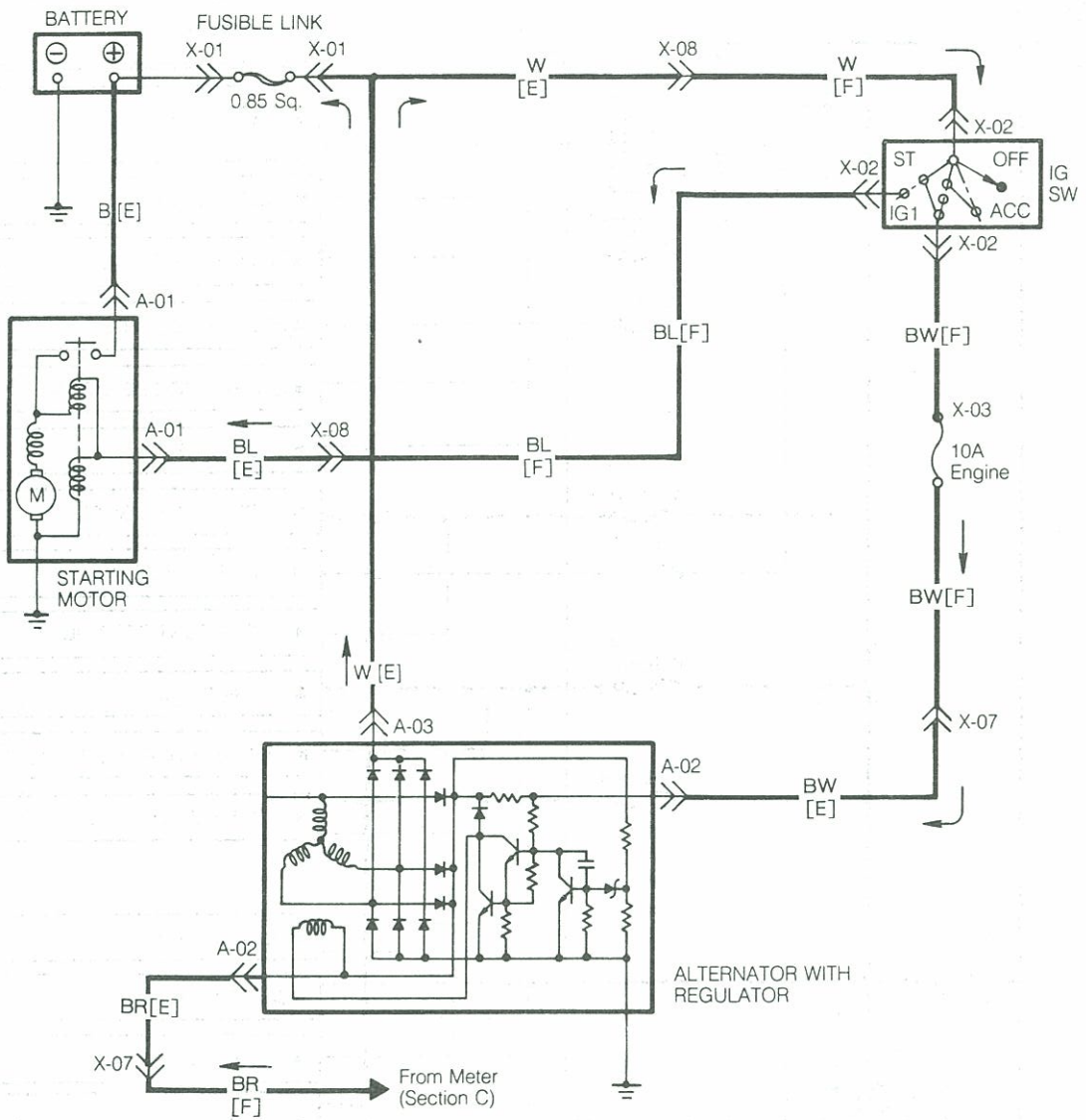

A-01 Starting Motor [E]

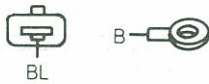

A-02 Alternator With Regulator [E]



A-03 Alternator With Regulator [E]



<p>A-01 Starting Motor [E]</p>	<p>A-02 Alternator With Regulator [E]</p>	<p>A-03 Alternator With Regulator [E]</p>	

RHD

A

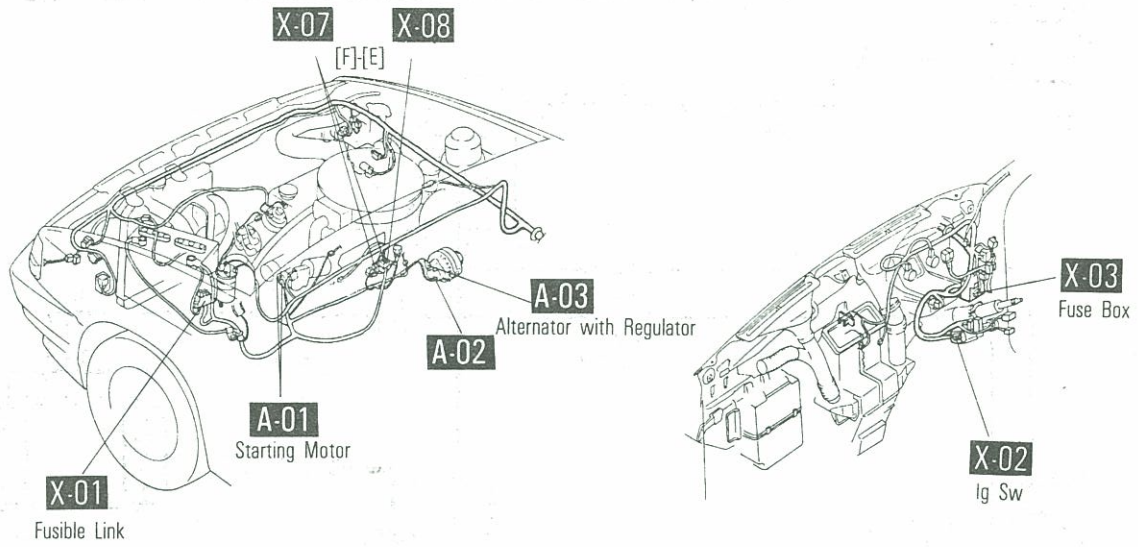

LHD

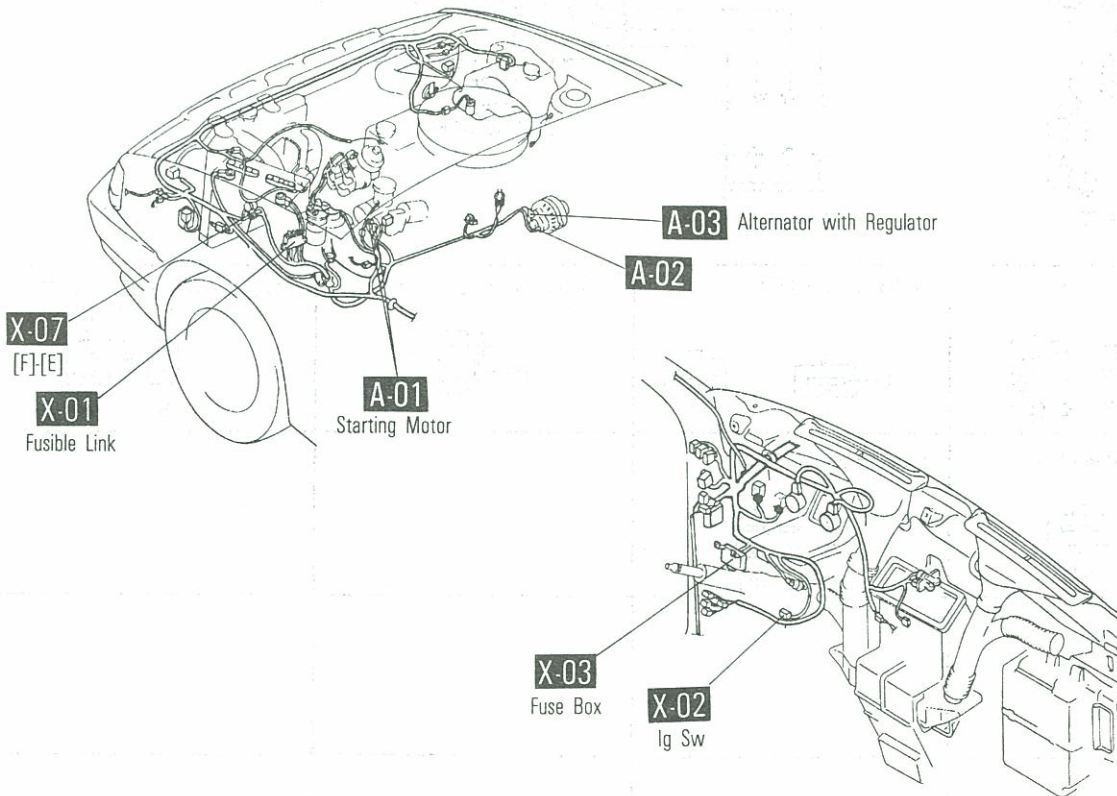

B

■ IGNITION SYSTEM ■ COOLING FAN SYSTEM

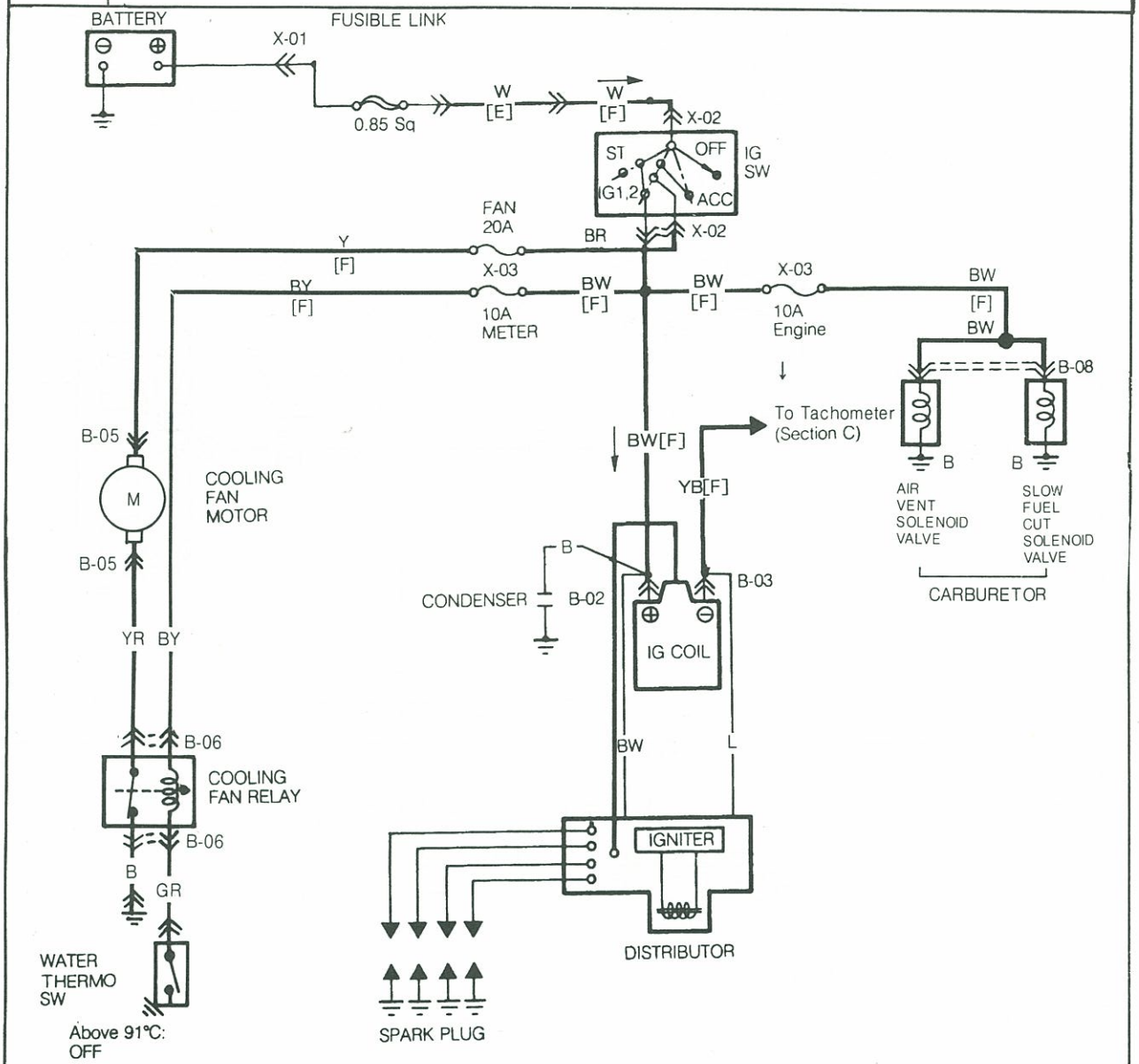

<p>B-02 Ig Coil ⊕ [F]</p>	<p>B-03 Ig Coil ⊖ [F]</p>	<p>B-05 Cooling Fan Motor [F]</p>	<p>B-06 Cooling Fan Relay [F]</p>
<p>B-07 Water Thermo Sw [F]</p>	<p>B-08 Carburetor [E]</p>		

RHD

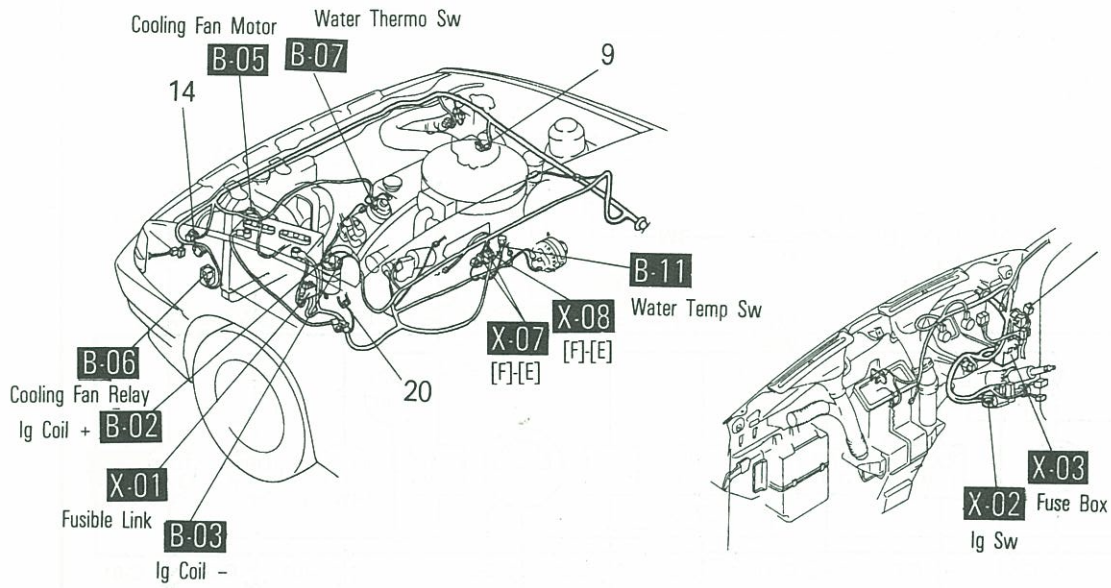

LHD

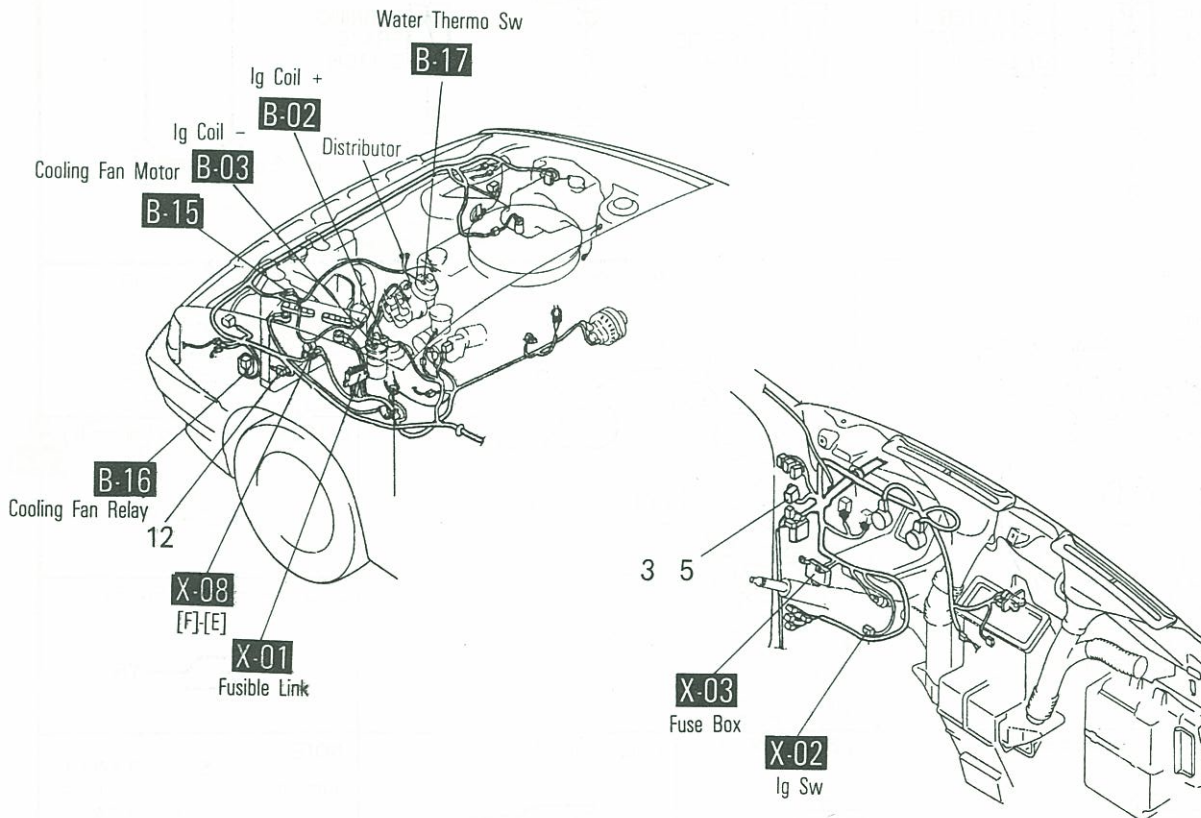

C

METERS & WARNING LIGHTS

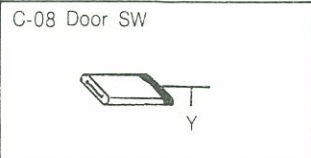
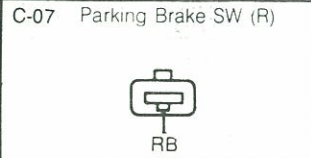
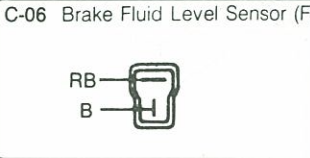
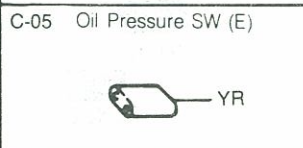
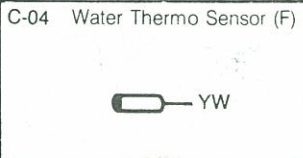
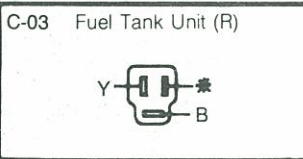
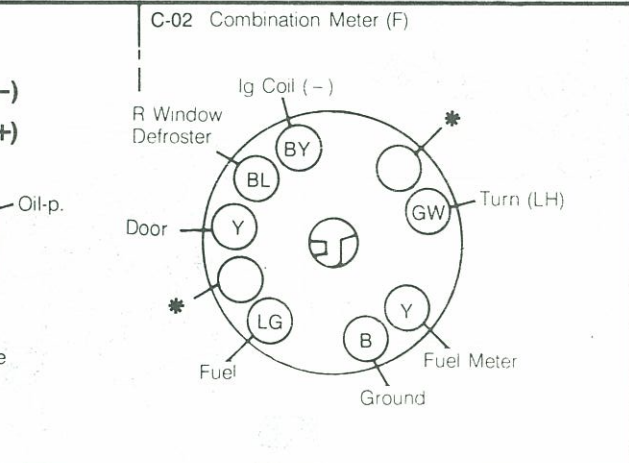
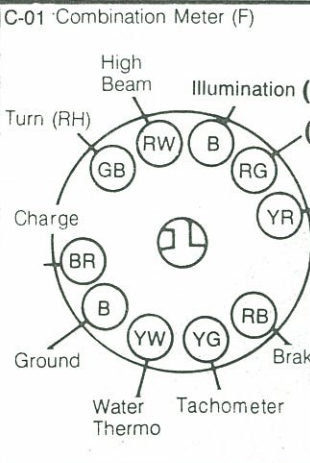
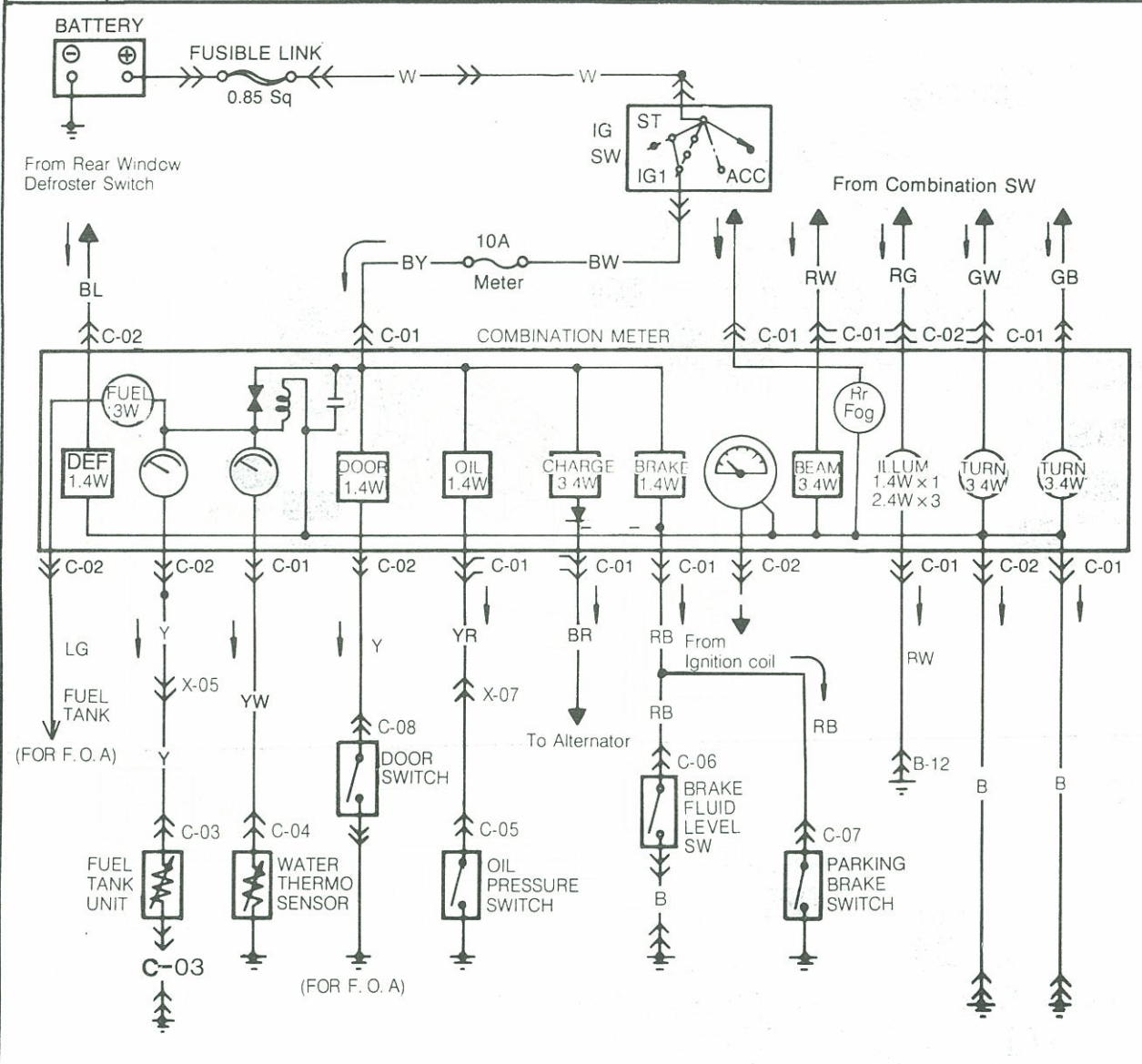

NOTE:

STD:	3.4W x 1
Illumination	1.4W x 4
DLX:	3.4W x 3
	1.4W x 3

(For U. K.)

RHD

C

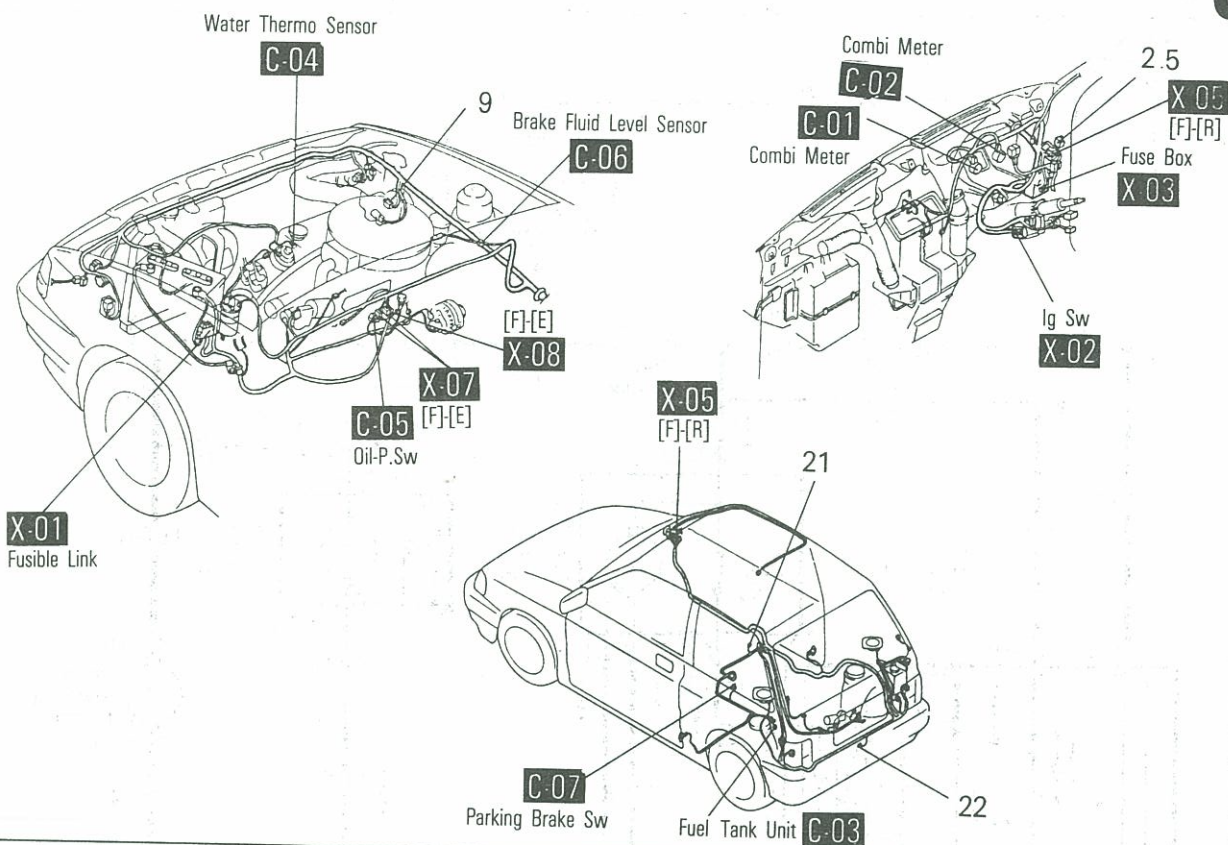

LHD

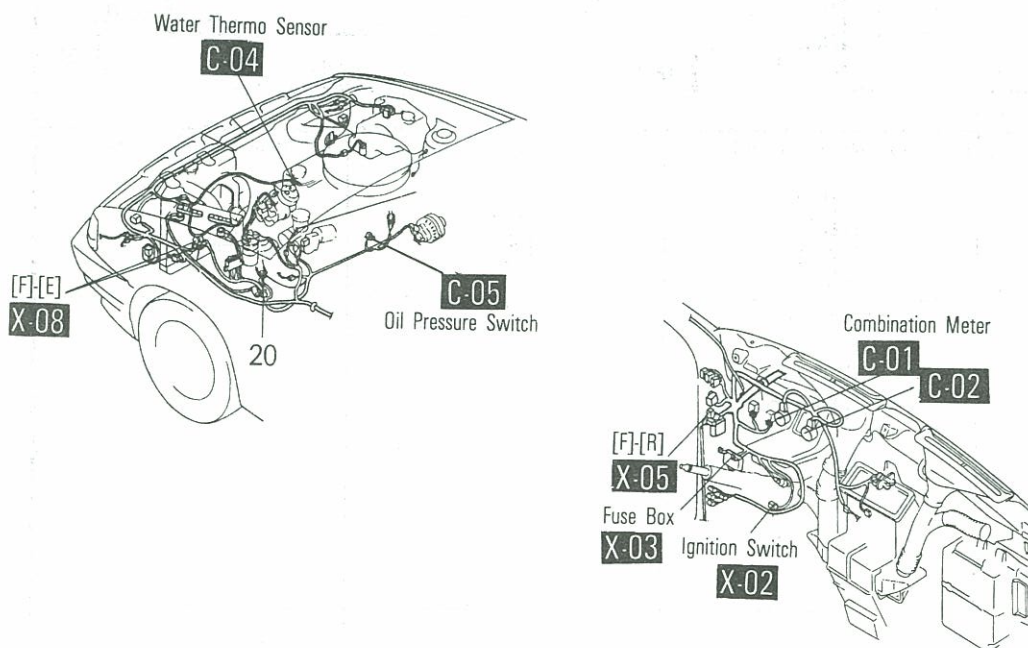

D

FRONT WIPER & WASHER REAR WIPER & WASHER

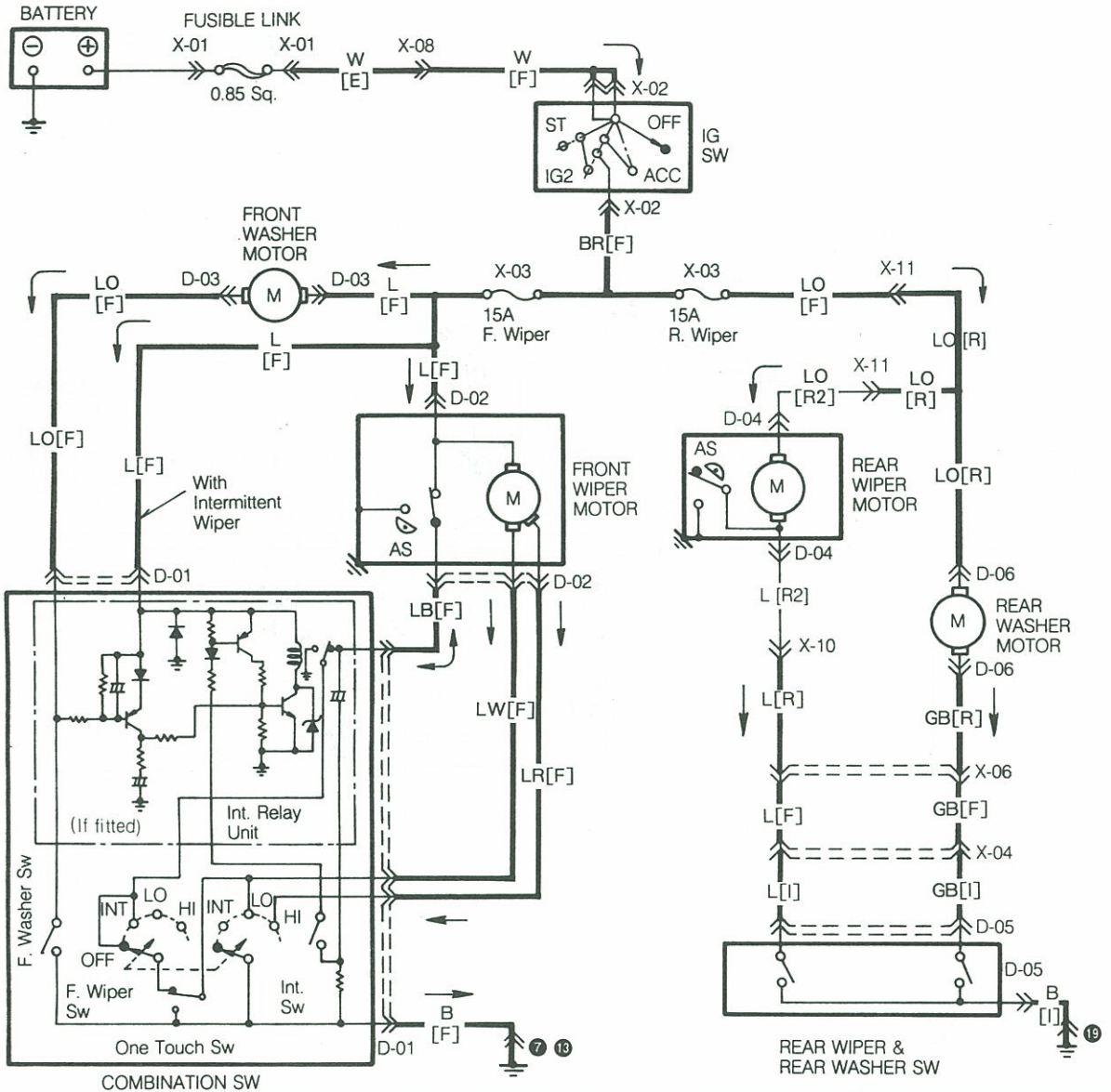

<p>D-01 Combination Sw [F] () : LHD (LO) B L LO(B) (LW) LR LB LW (LR)</p>	<p>D-02 Front Wiper Motor [F] </p>	<p>D-03 Front Washer Motor [F] </p>	<p>D-04 Rear Wiper Motor [R2] </p>
<p>D-05 Rear Wiper & Washer Sw [I] </p>	<p>D-06 Rear Washer Motor [R] </p>		

RHD

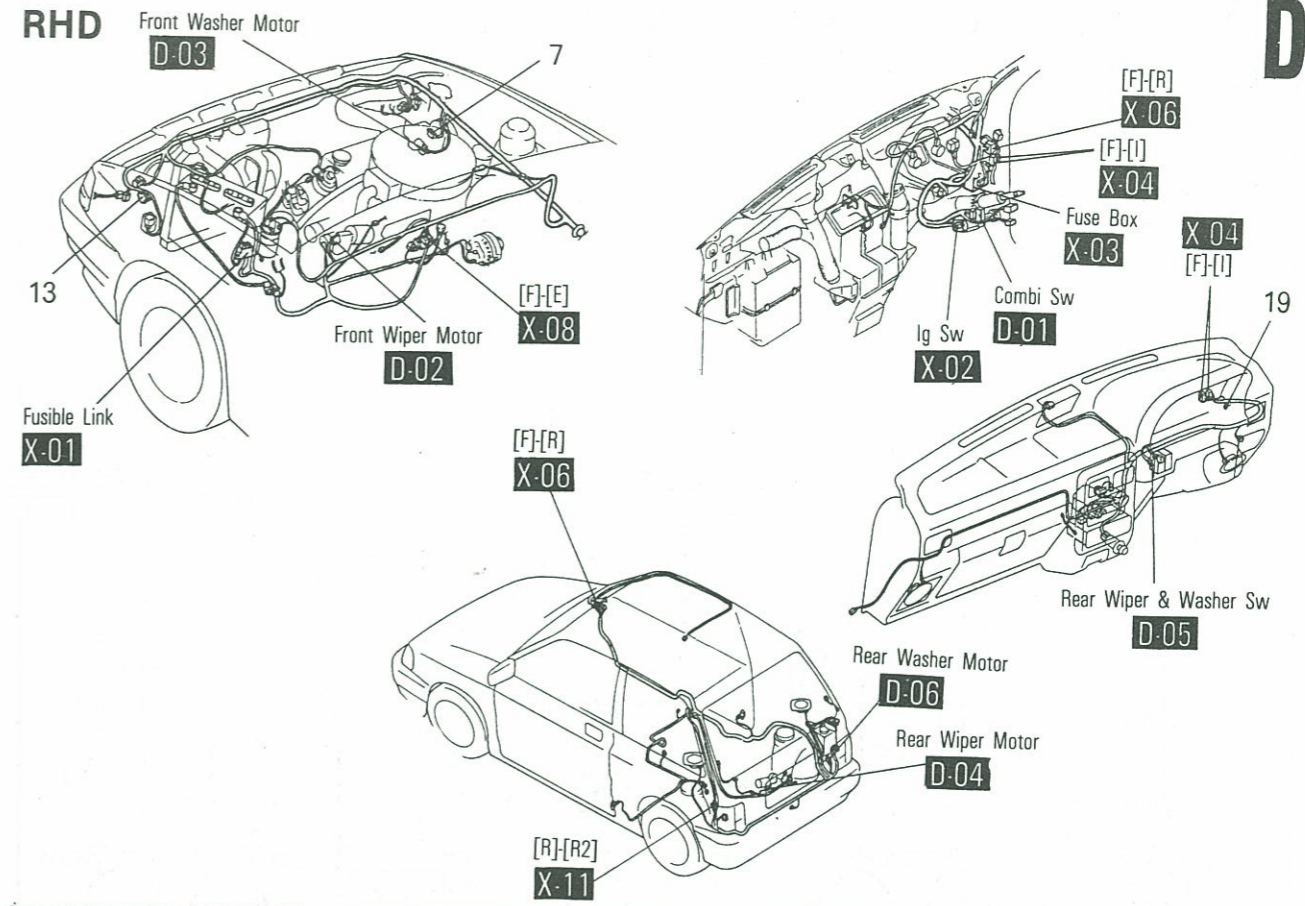

LHD

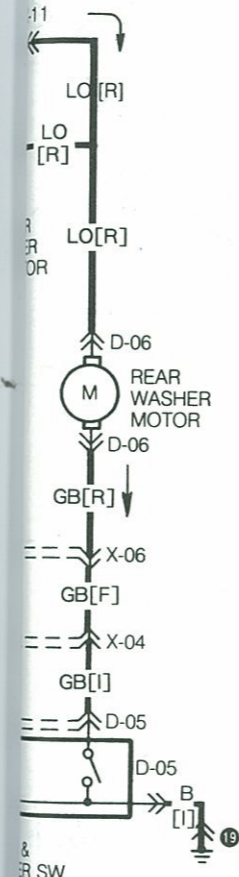
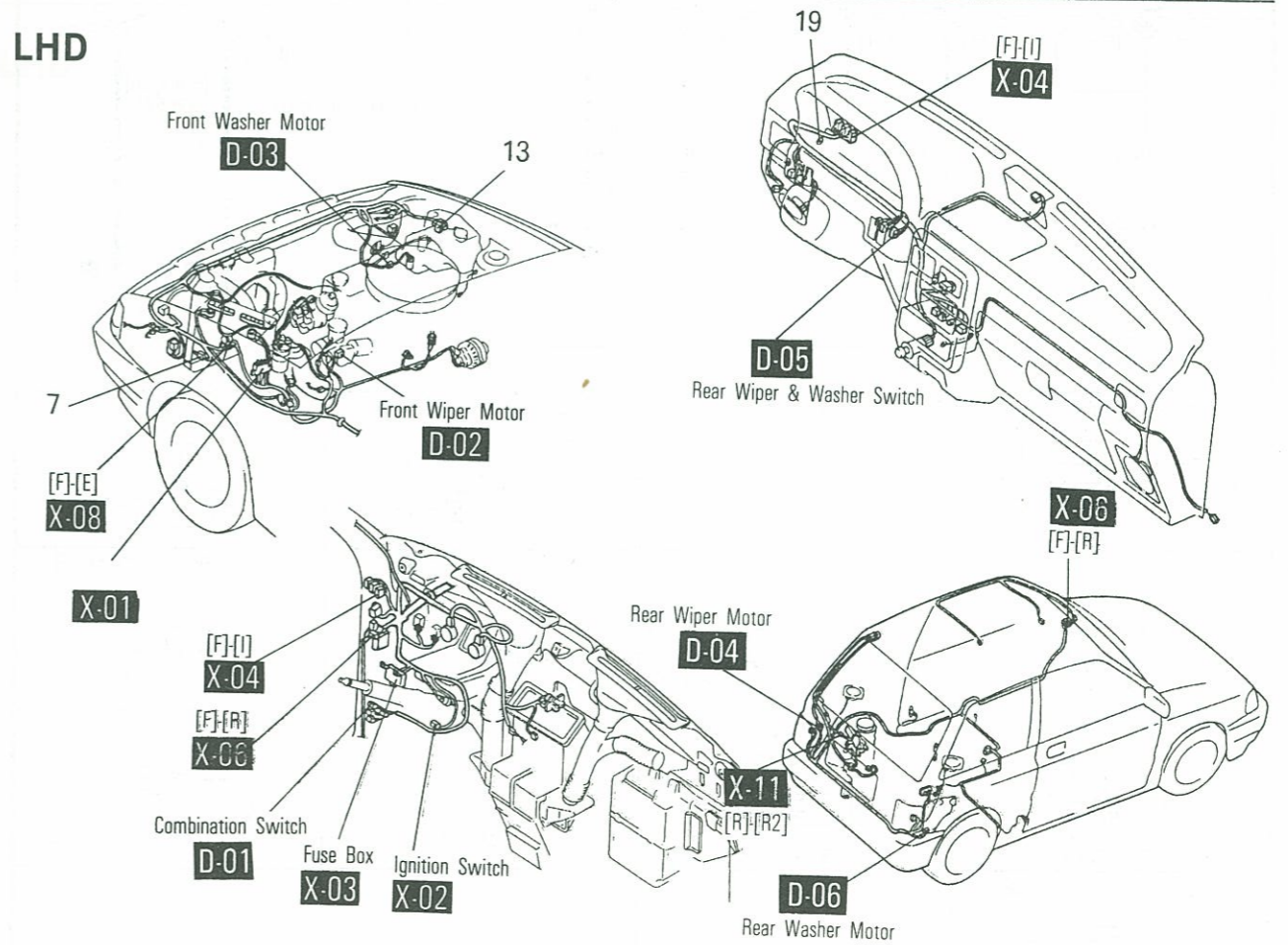

Rear Wiper Motor [R2]

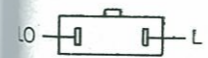

E

■ HEADLIGHTS ■ TAIL LIGHTS ■ FRONT SIDE LIGHTS ■ LICENSE LIGHTS ■ ILLUMINATION LIGHTS

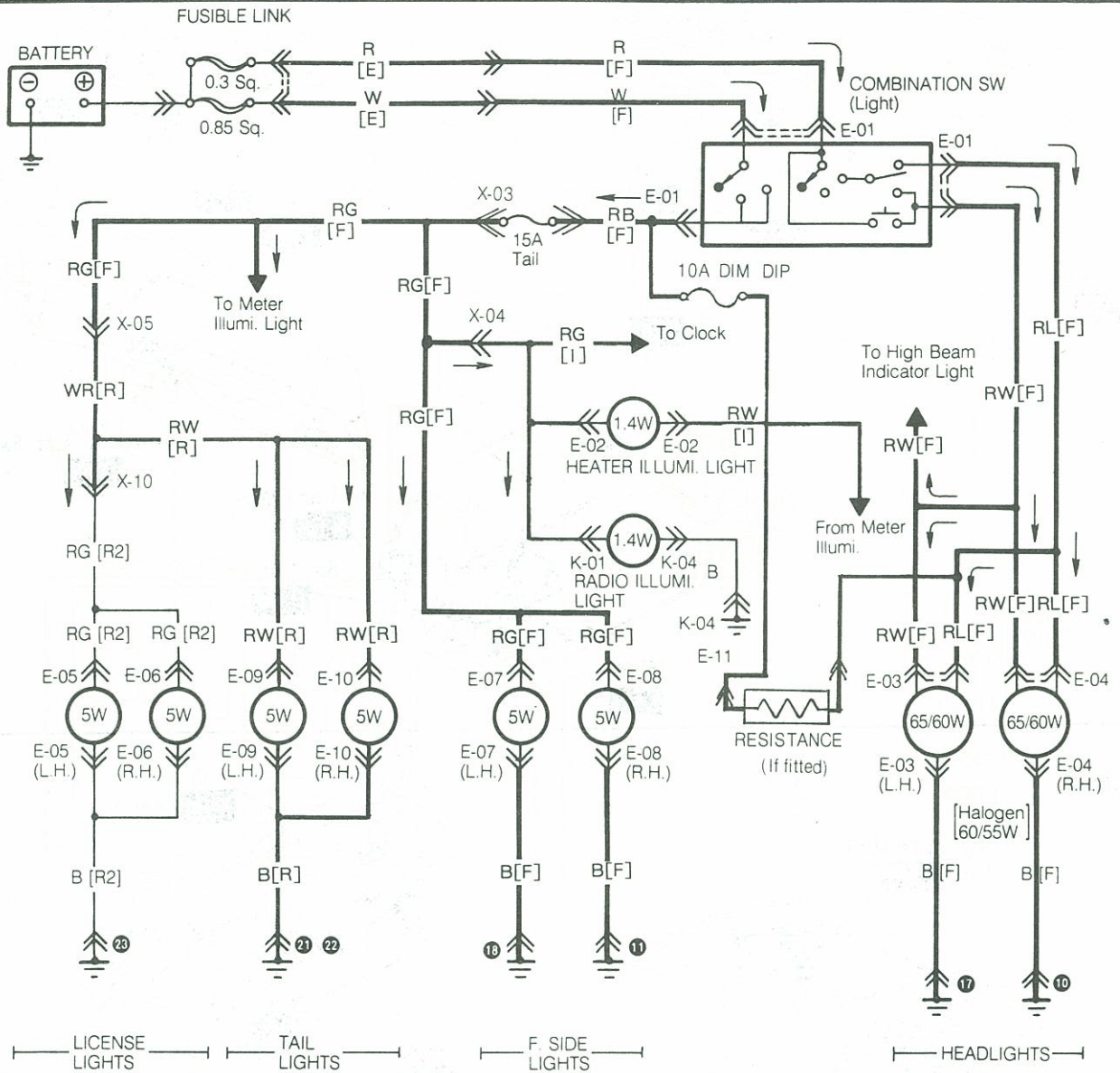

<p>E-01 Combination Sw [F]</p>	<p>E-02 Heater Illumination Light [I]</p>	<p>E-03 Headlight L.H. [F]</p>	<p>E-04 Headlight R.H. [F]</p>
<p>E-05 License Light L.H. [R2]</p>	<p>E-06 License Light R.H. [R2]</p>	<p>E-07 Front Side Light L.H. [F]</p>	<p>E-08 Front Side Light R.H. [F]</p>
<p>E-09 Rear Combination Light L.H. [R]</p>	<p>E-10 Rear Combination Light R.H. [R]</p>	<p>K-01 Radio Illumination Light [I]</p>	<p>K-04 Ground Cord</p>
<p>E-11 DIM DIP RESISTANCE</p>			

RHD

E

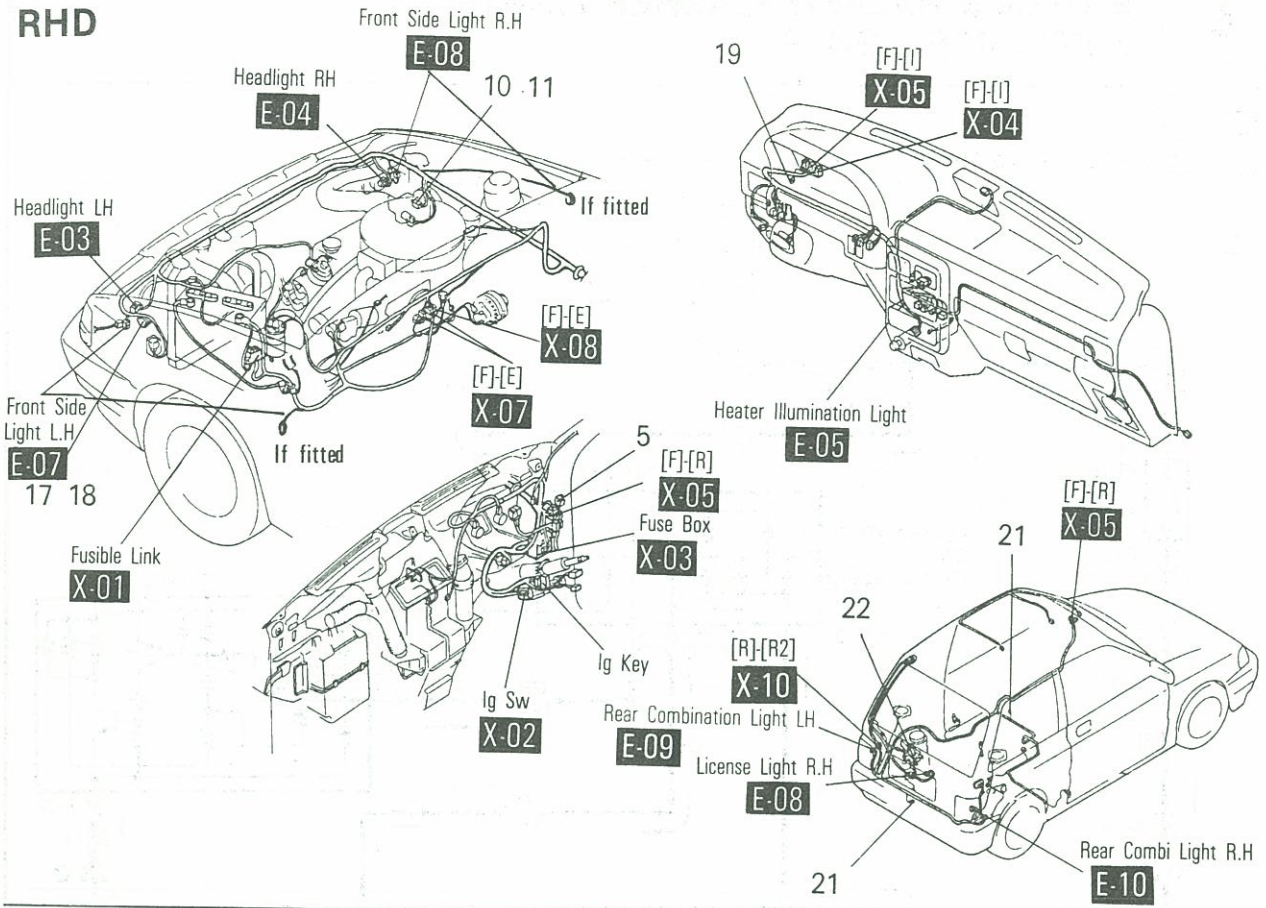



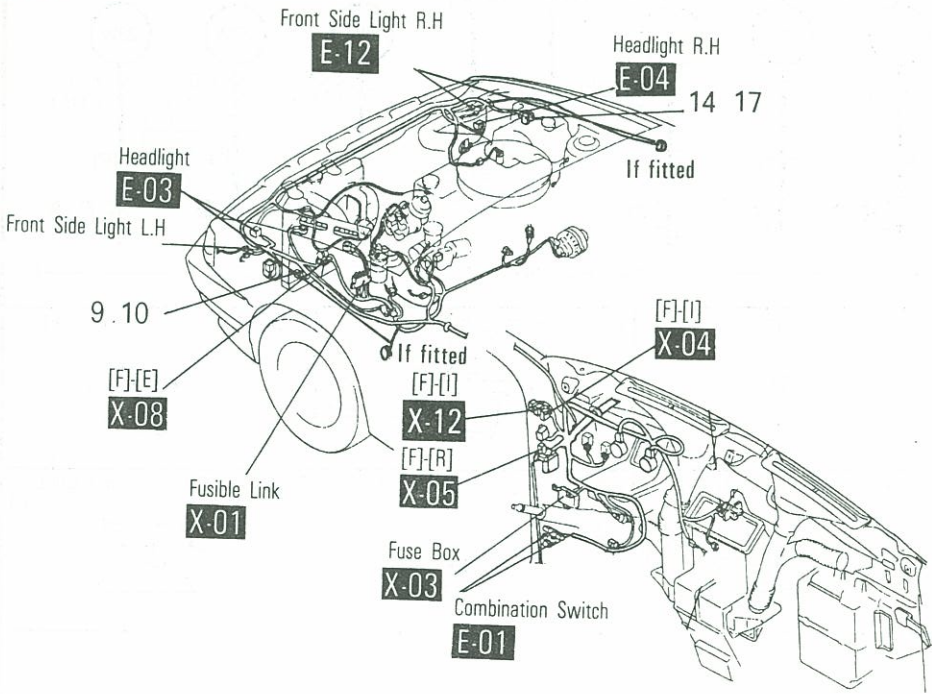



LHD

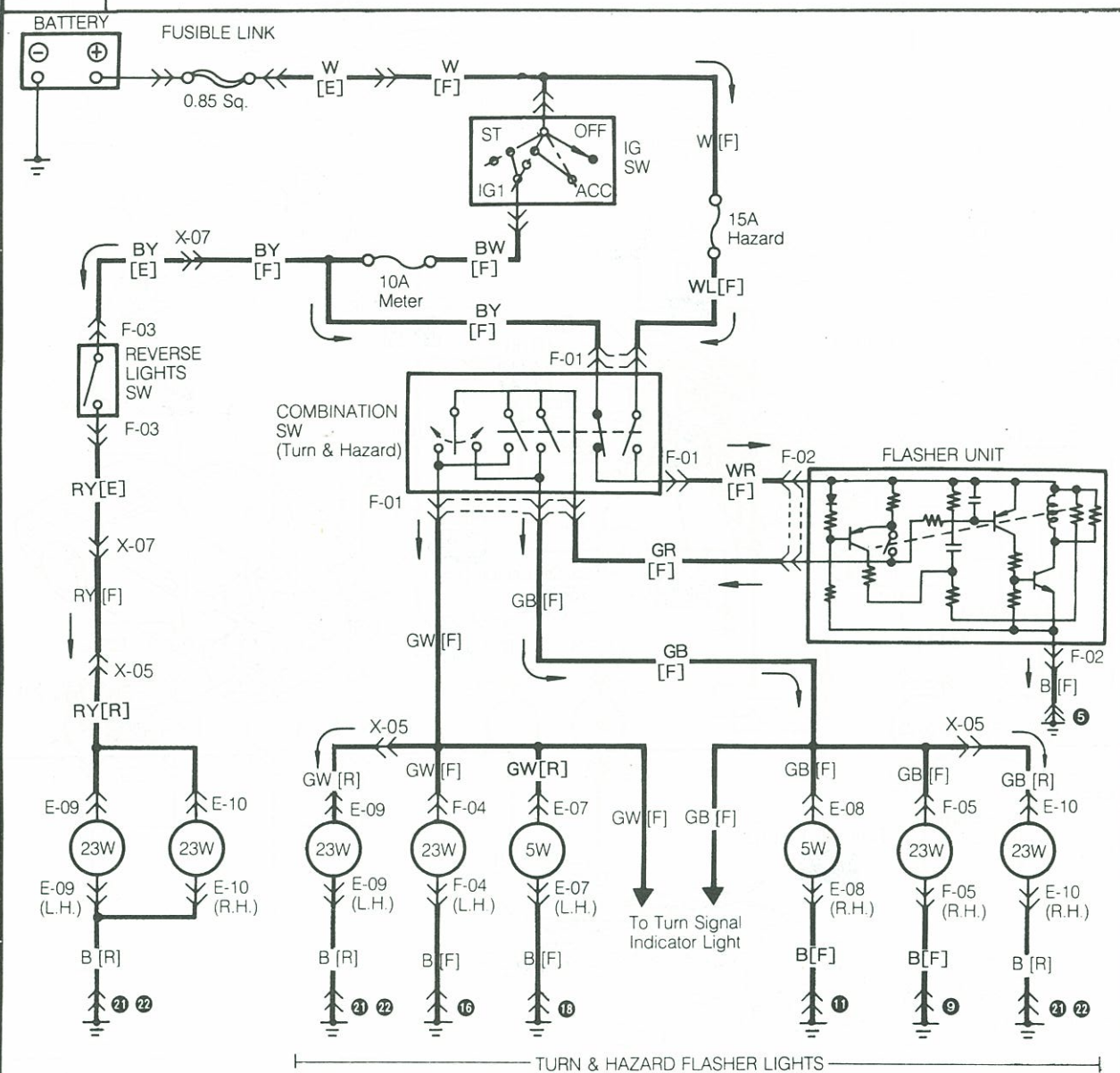

F

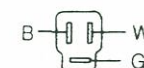
TURN & HAZARD FLASHER LIGHTS REVERSE LIGHTS

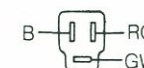
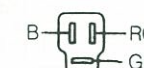
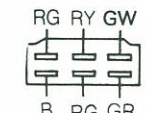
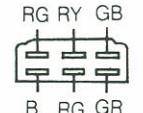

<p>F-01 Combination Sw [F] () LHD (BY) (WL) (GW) WL WR BY (GR) GB GR GW</p> 	<p>F-02 Flasher Unit [F]</p> 	<p>F-03 Reverse Light Sw [E]</p> 	<p>F-04 Front Turn Light L.H. [F]</p> 
<p>F-05 Front Turn Light R.H. [F]</p> 	<p>E-07 Front Side Light L.H. [F]</p> 	<p>E-08 Front Side Light R.H. [F]</p> 	<p>E-09 Rear Combination Light L.H. [R]</p> 
<p>E-10 Rear Combination Light R.H. [R]</p> 			

RHD

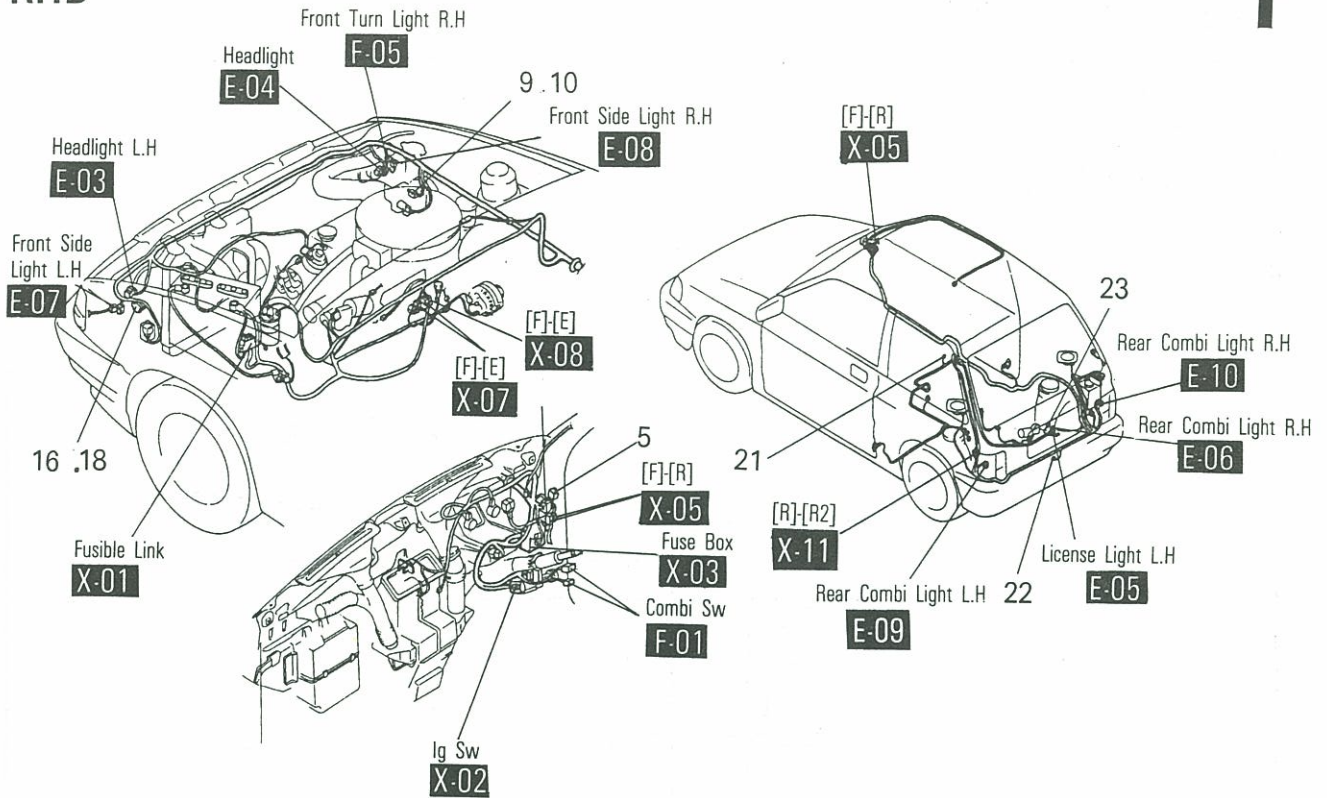

LHD

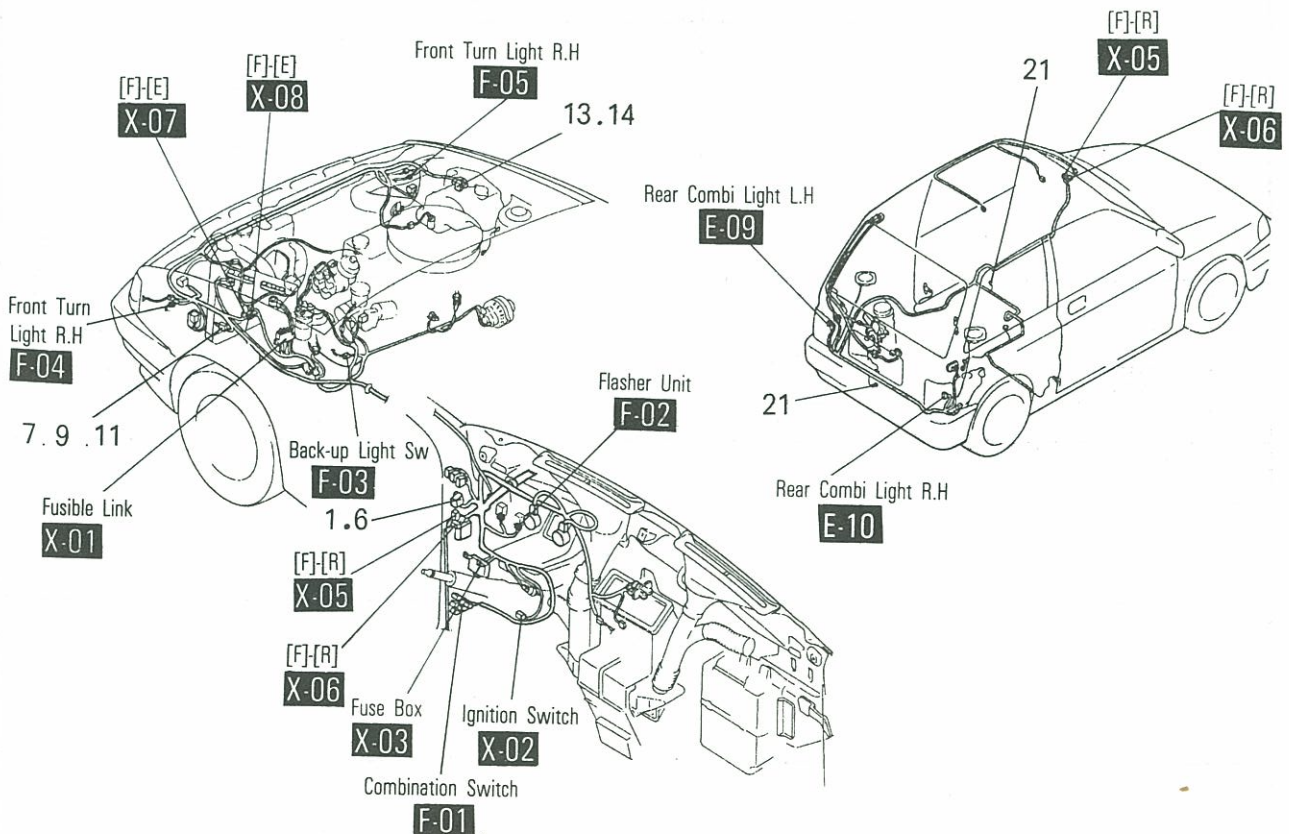

G

HEATER

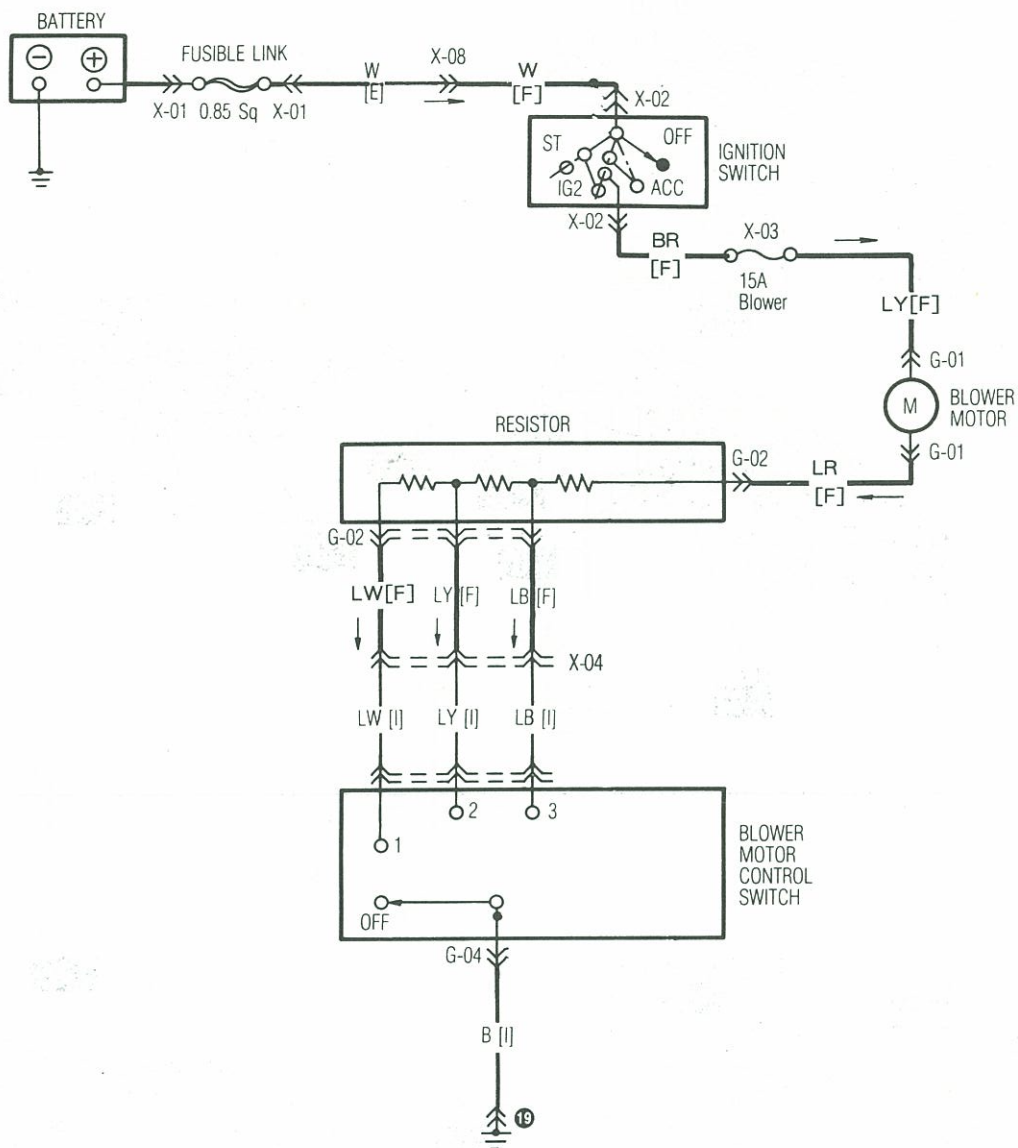

G-01 Blower Motor [F]



G-02 Resistor [F]

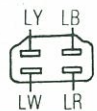

G-03 Resistor [F]



G-04 Blower Motor Control Switch [I]

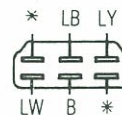

RHD

G

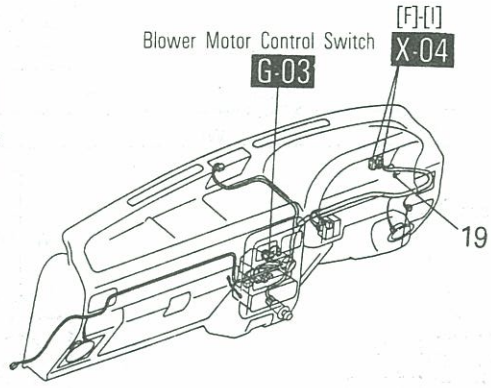
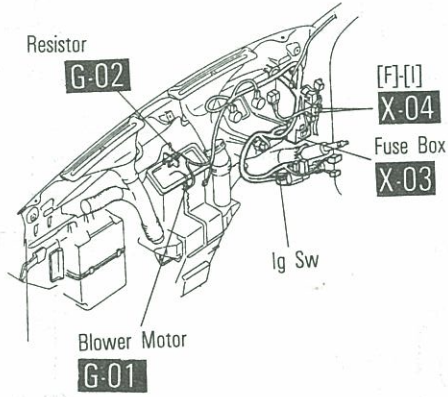

LHD

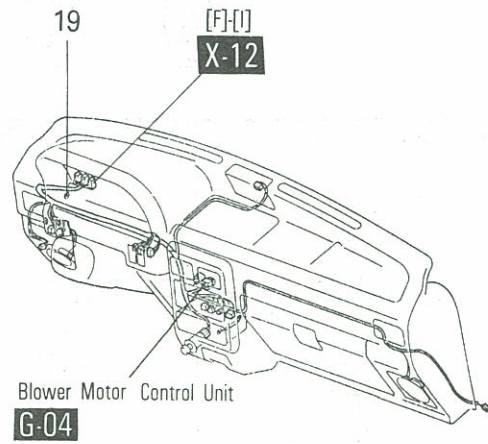
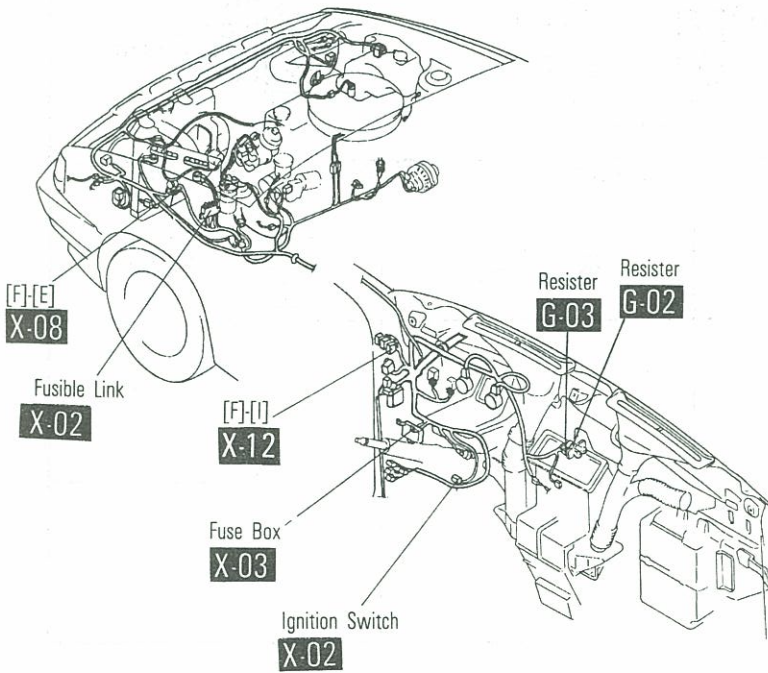

H

■ CLOCK ■ INTERIOR LIGHT ■ LUGGAGE COMPARTMENT LIGHT

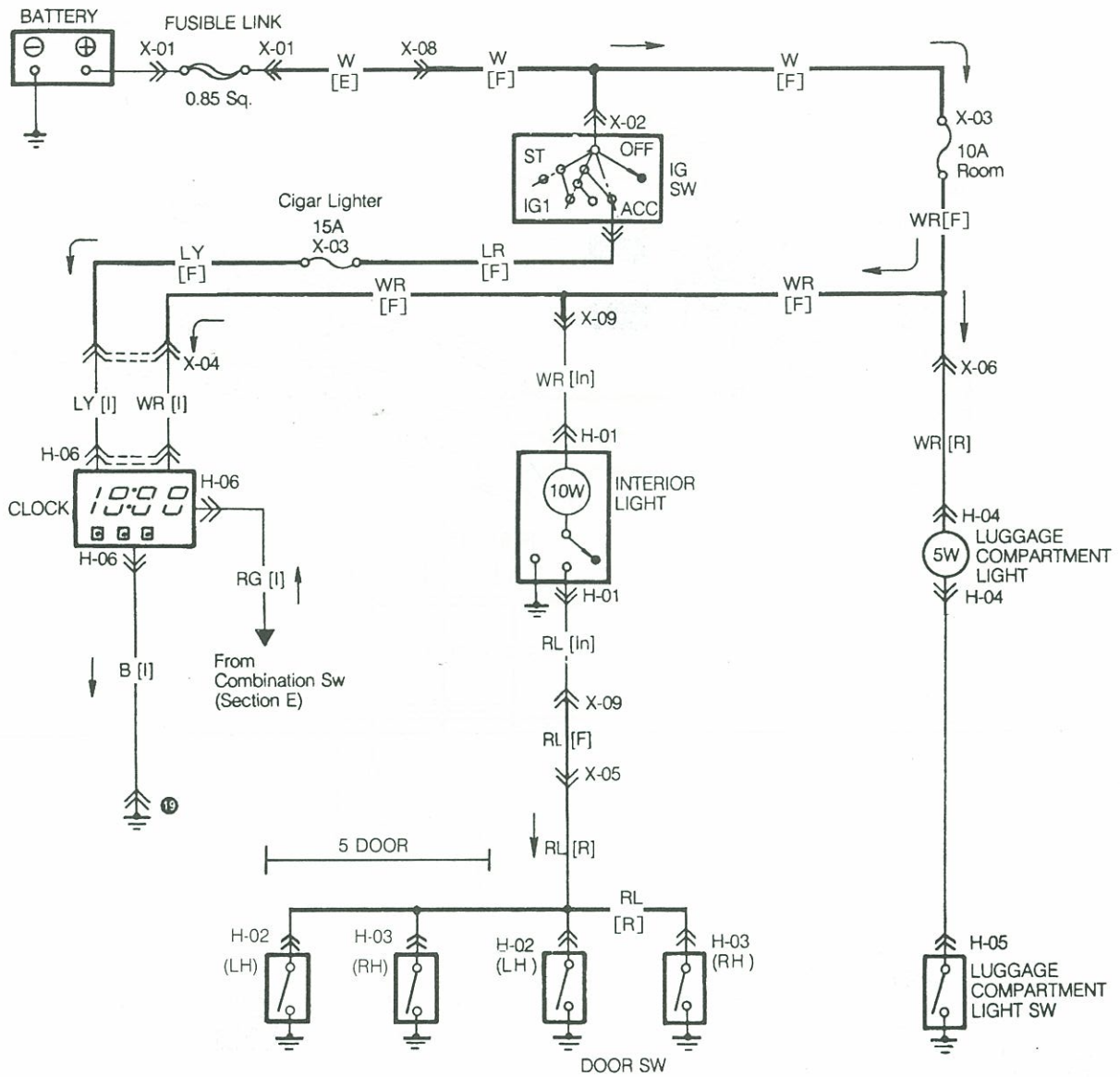

H-01 Interior Light [In]



H-02 Door Sw L.H. [R]



H-03 Door Sw R.H. [R]



H-04 Luggage Compartment Light [R]



H-05 Luggage Compartment Light Sw [R2]



H-06 Clock [I]

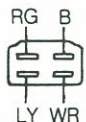

RHD

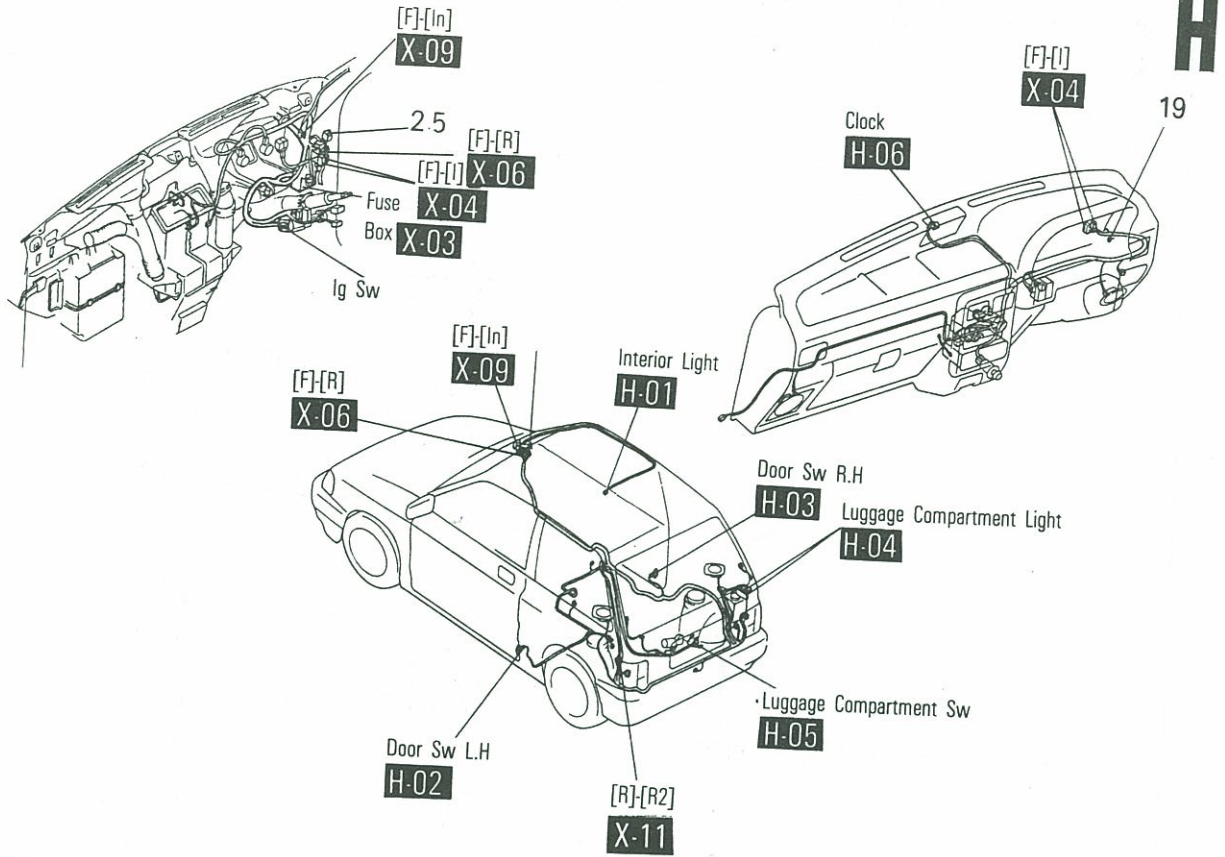



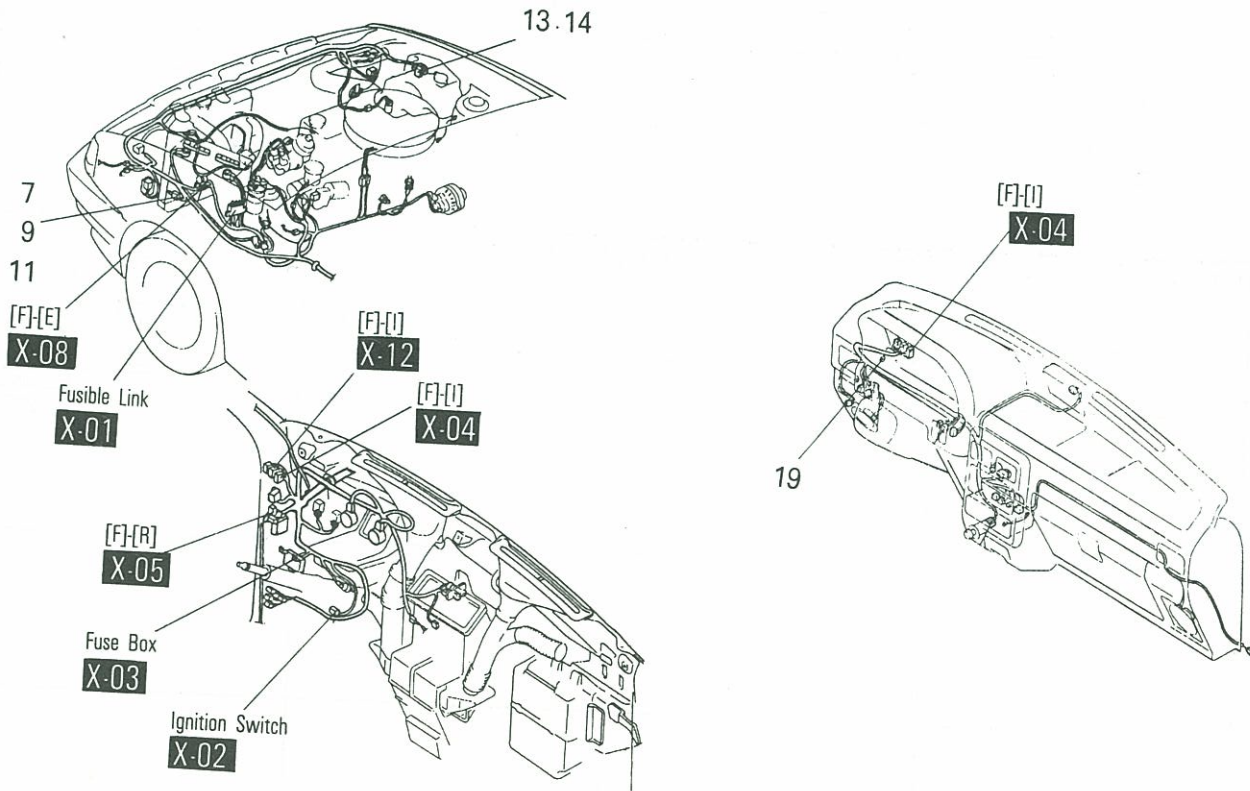

LHD

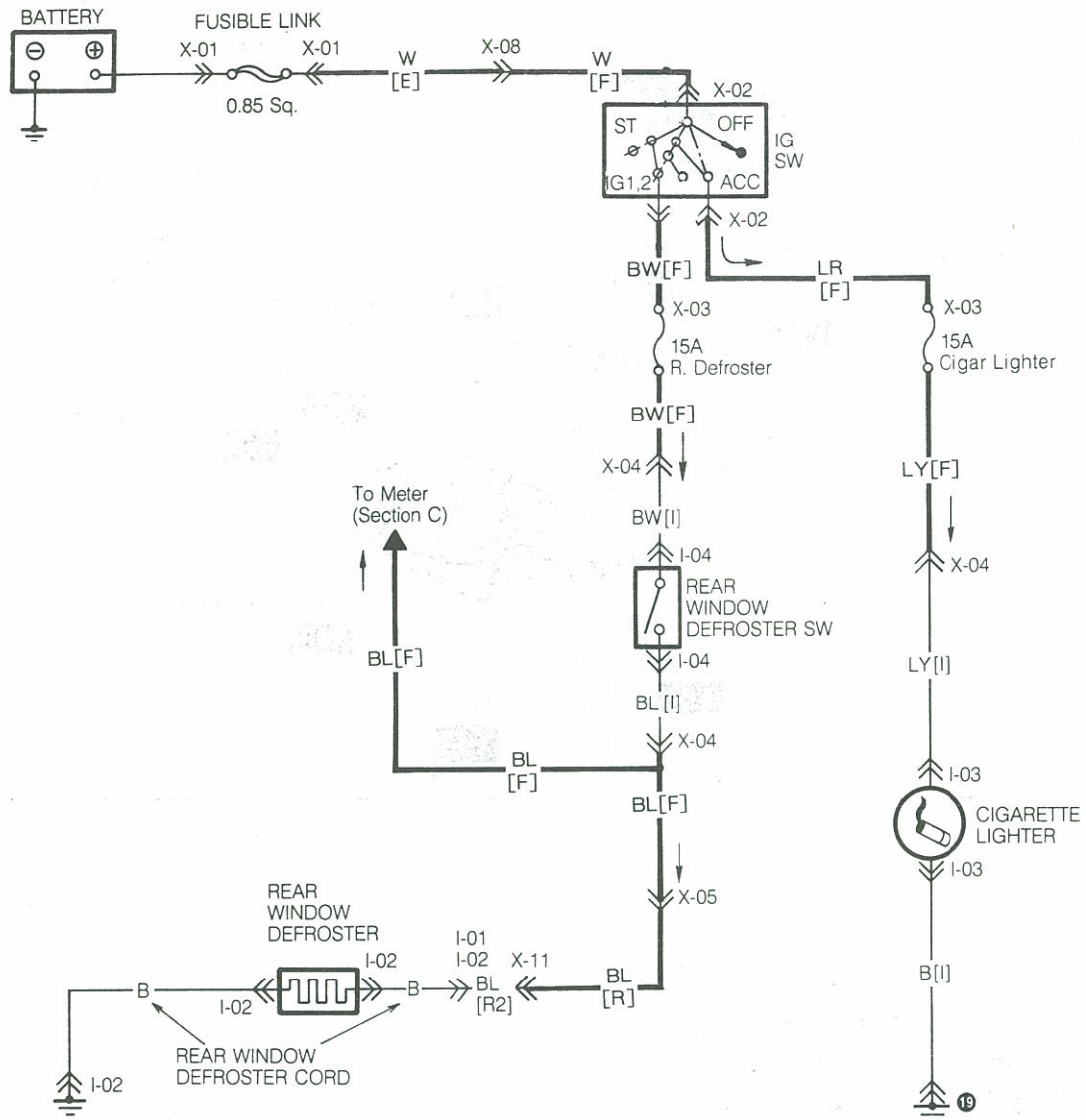

REAR WINDOW DEFROSTER CIGARETTE LIGHTER

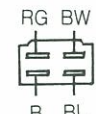

I-01 Rear Window Defroster [R2]	I-02 Rear Window Defroster Cord	I-03 Cigarette Lighter [I]	I-04 Defroster SW
	L.H.  — B R.H.  — B		

RHD

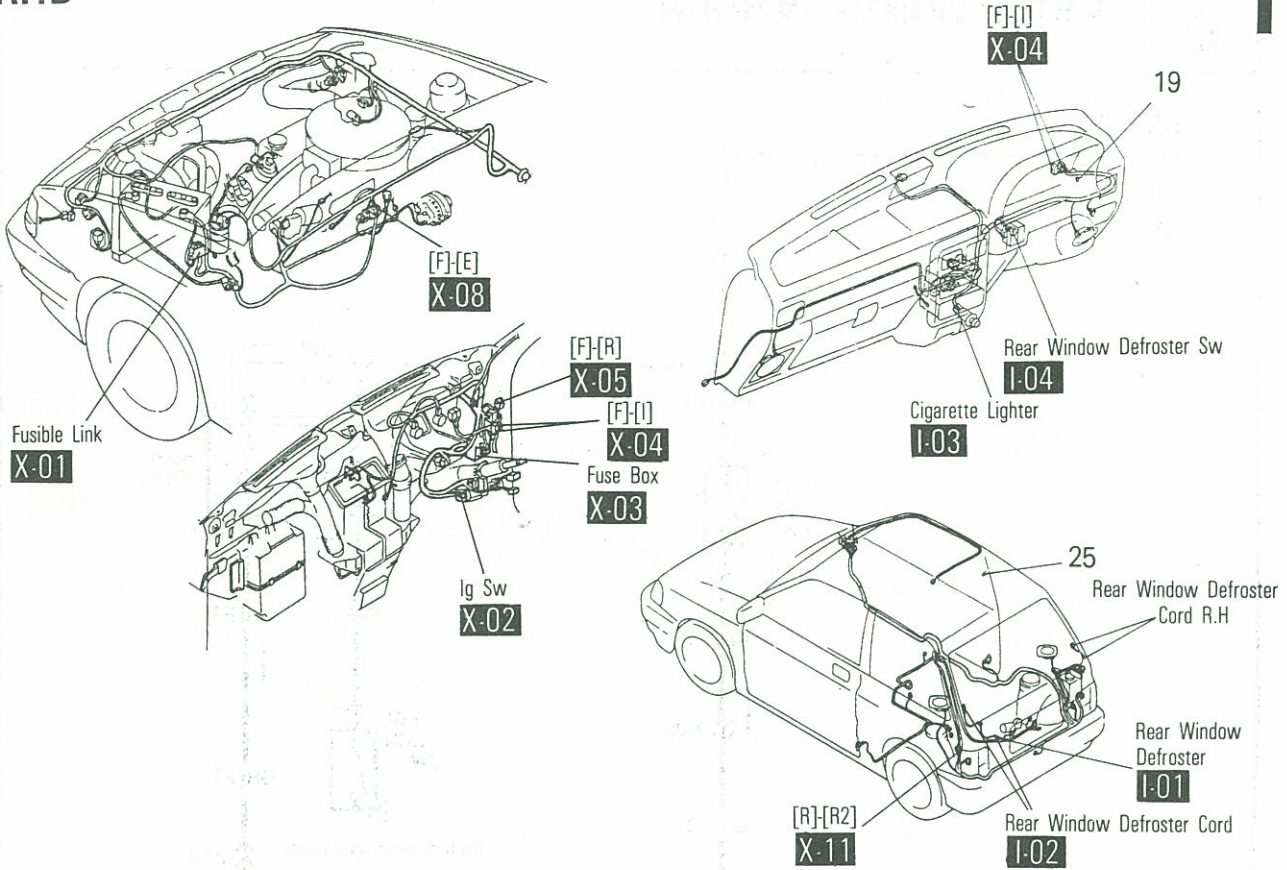



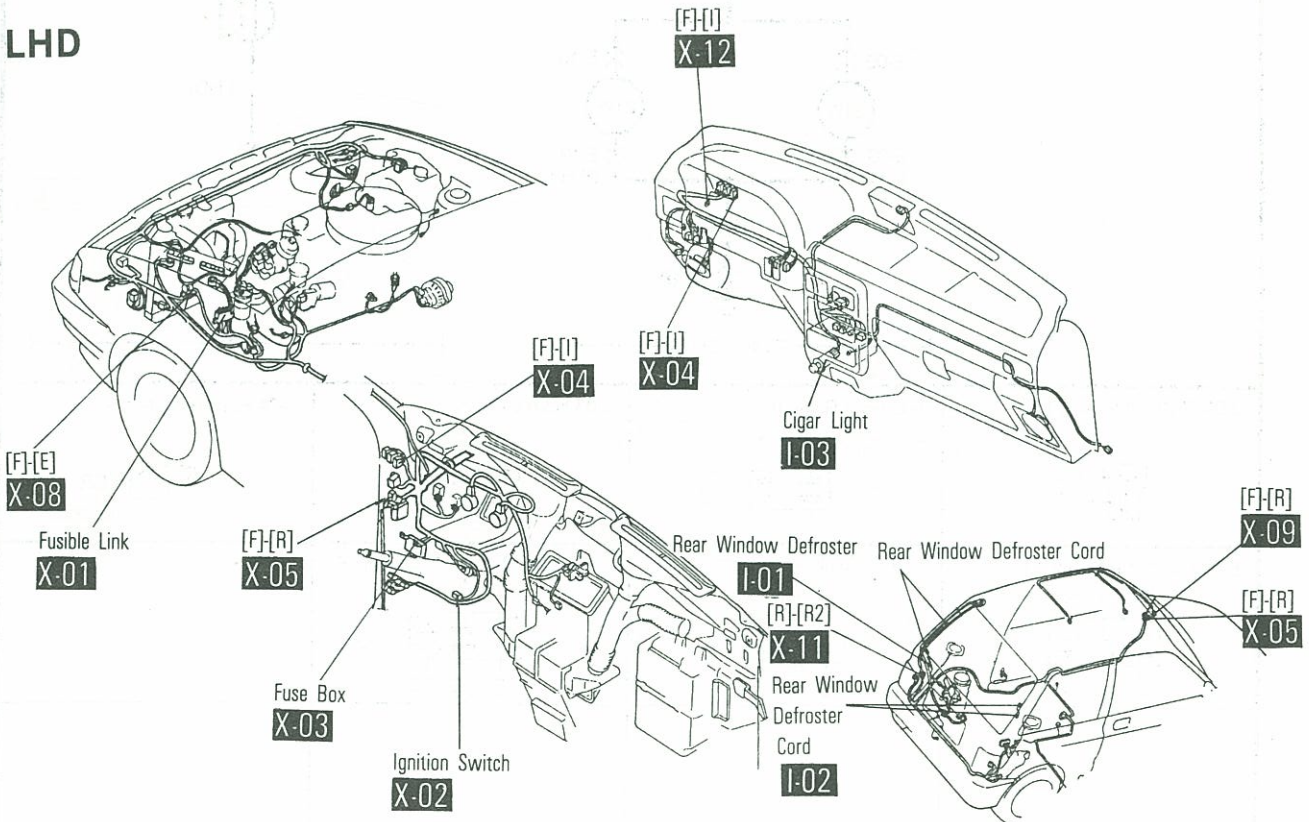

LHD

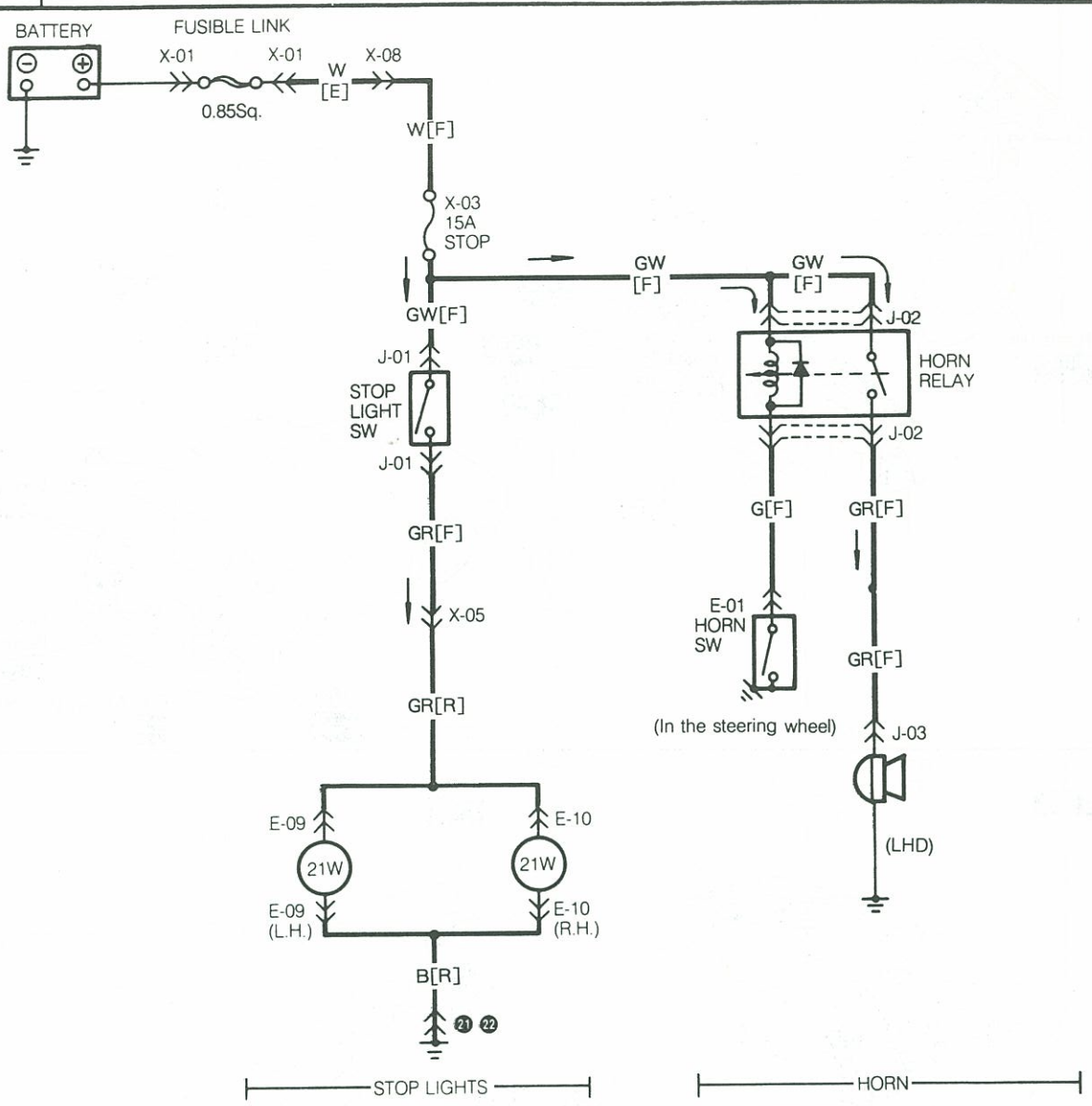

J

■ STOP LIGHTS ■ HORN

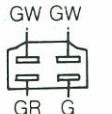

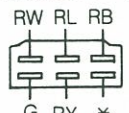
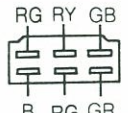
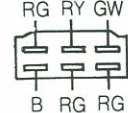
<p>J-01 Stop Light Sw [F]</p> 	<p>J-02 Horn Relay [F]</p> 	<p>J-03 Horn L.H. [F]</p> 	<p>J-04 Horn R.H. [F]</p> 
<p>E-01 Combination Sw [F]</p> 	<p>E-09 R. Combination Light L.H. [R]</p> 	<p>E-10 R. Combination Light R.H. [R]</p> 	

RHD

J

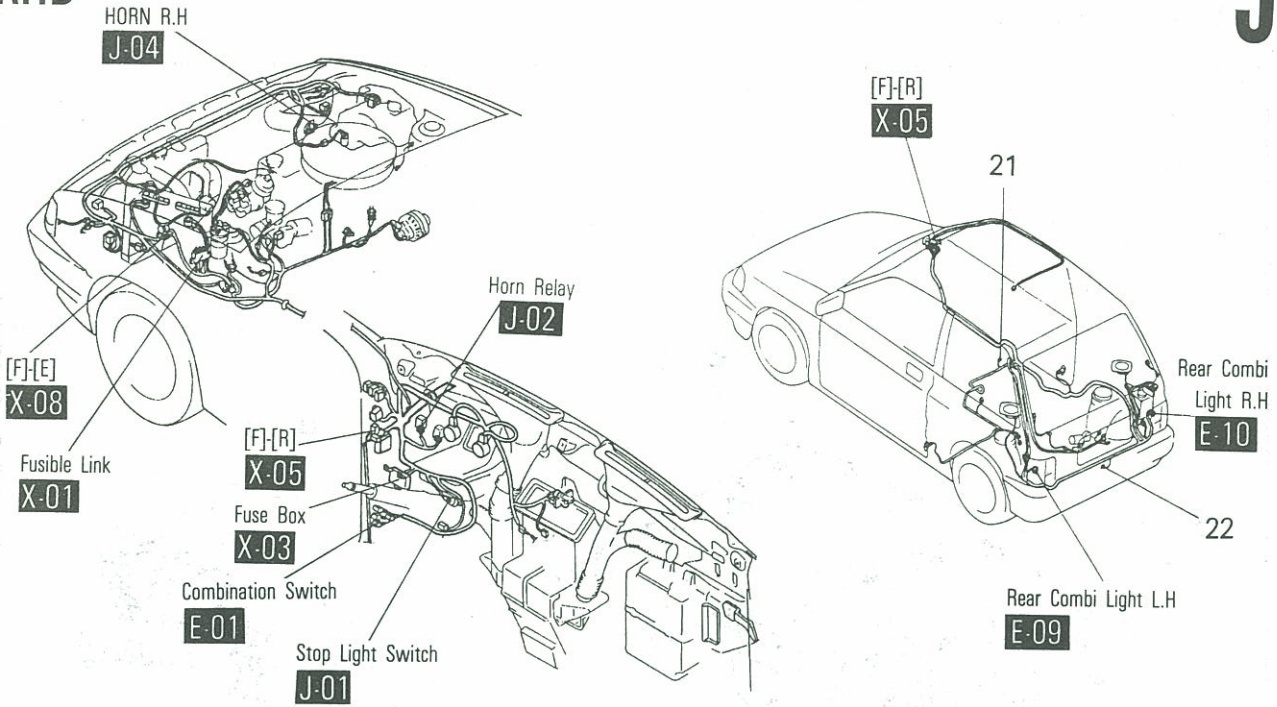

LHD

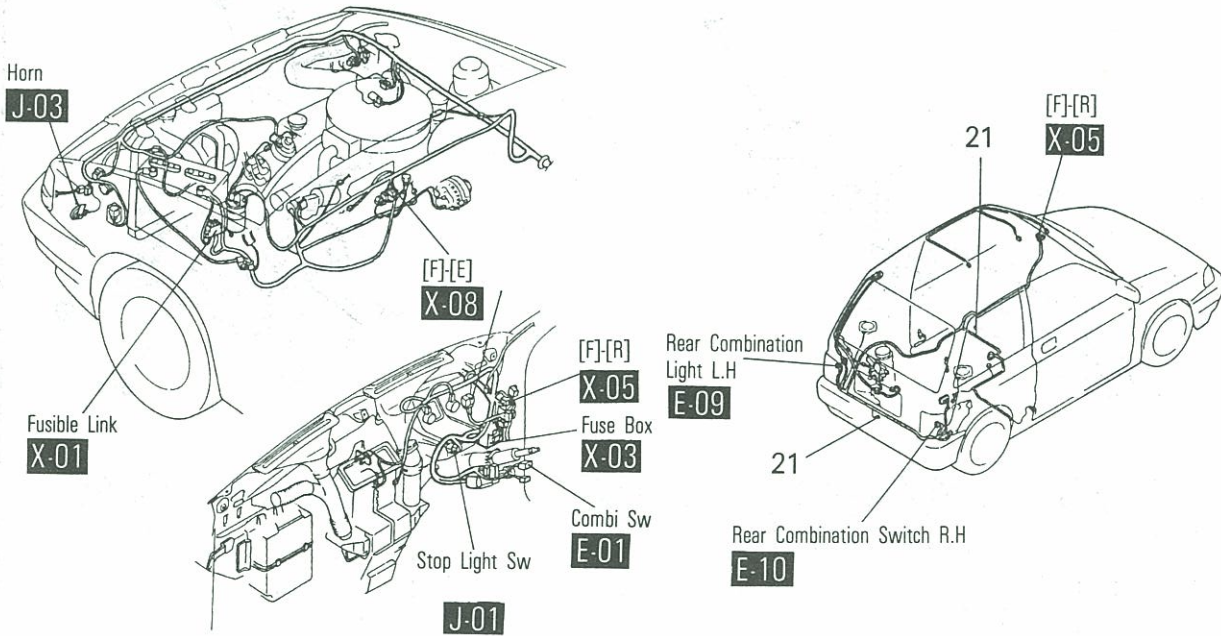

JC

JOINT CONNECTOR & GROUND CIRCUIT (RHD)

Note: Wiring Order into the Joint Connector may be Changed.

JC-01 No. 1 Joint Connector [F]

JC-02 No. 2 Joint Connector [F]

JC-03 No. 3 Joint Connector [F]

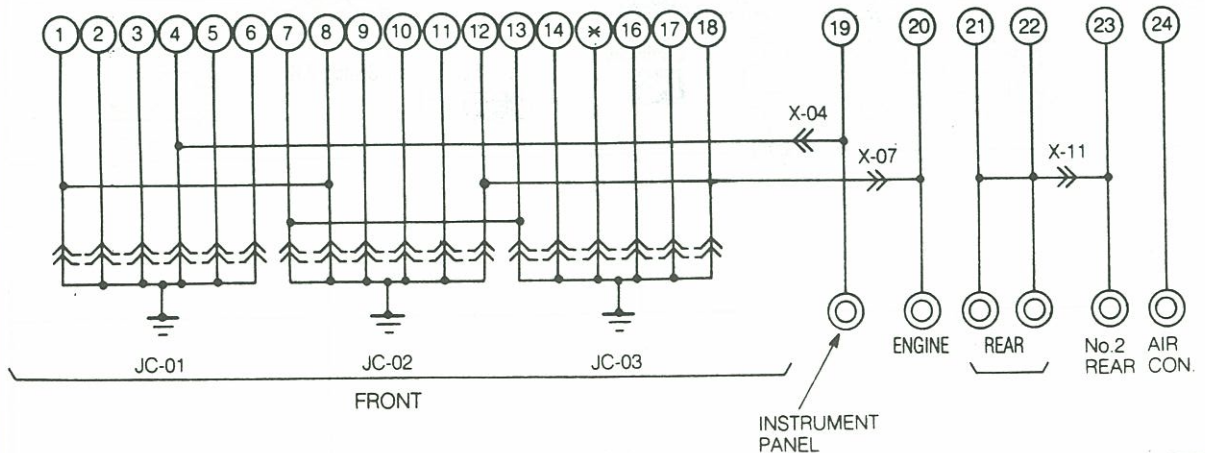
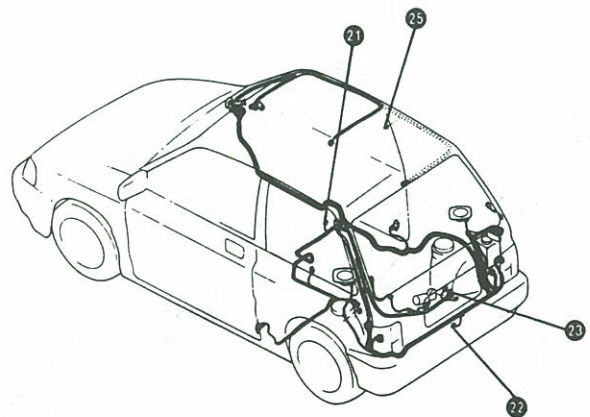
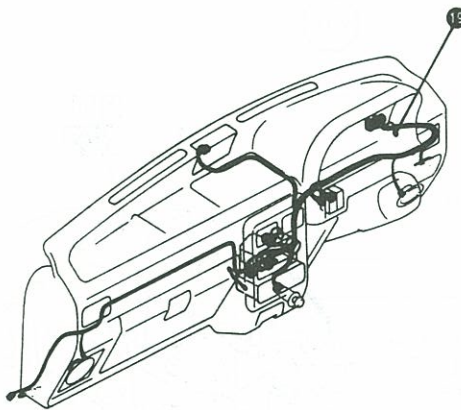
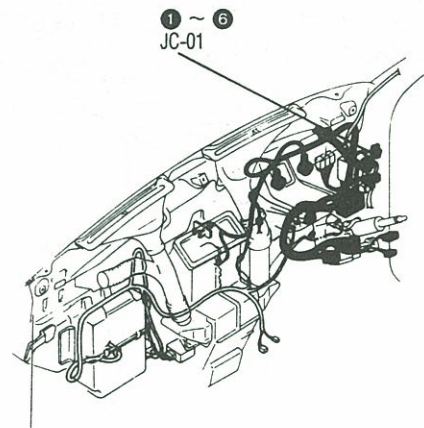
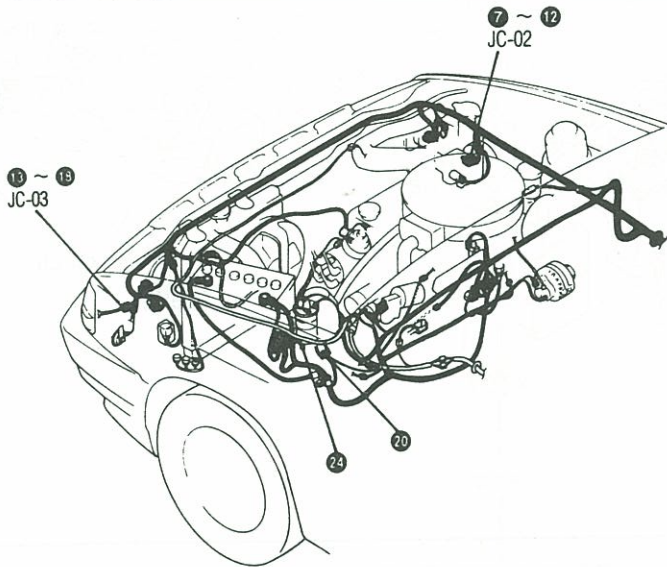
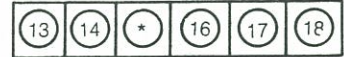
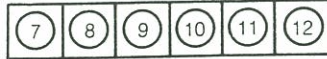

JOINT CONNECTOR & GROUND CIRCUIT (LHD)

Note: Wiring Order into the Joint Connector may be Changed

JC

JC-01 No. 1 Joint Connector [F]

JC-02 No. 2 Joint Connector [F]

JC-03 No. 3 Joint Connector [F]

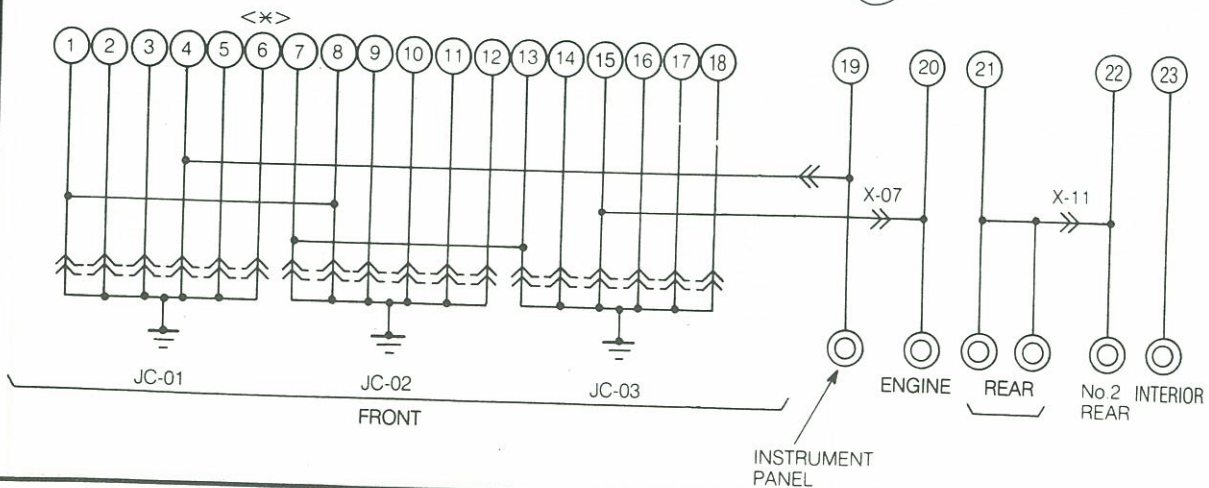
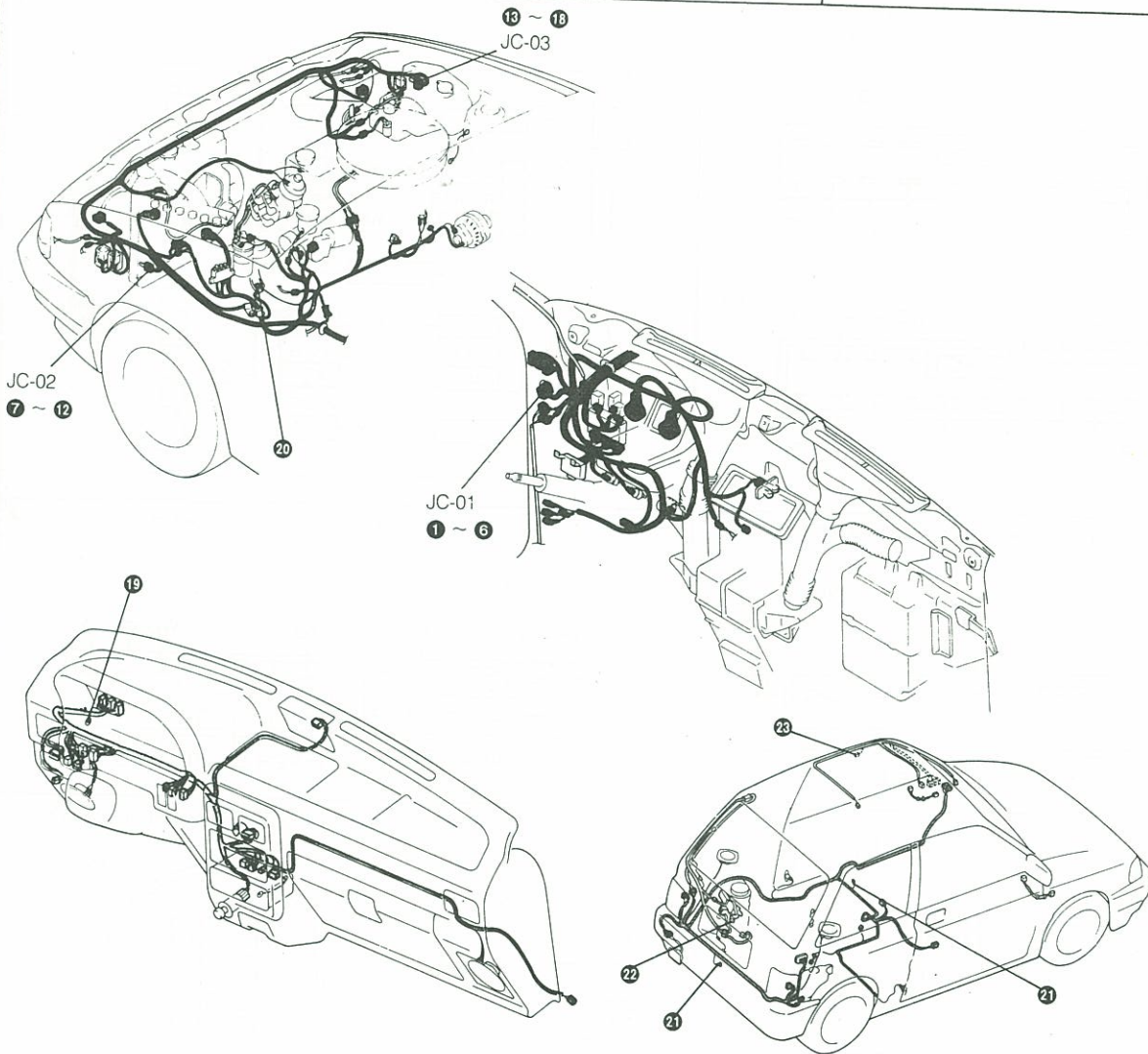
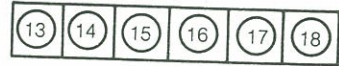
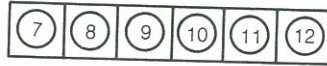
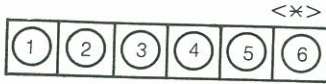

COMMON CONNECTOR LIST

Note: Wiring Order into the common connector list may be changed.

X

X-01 Fusible Link

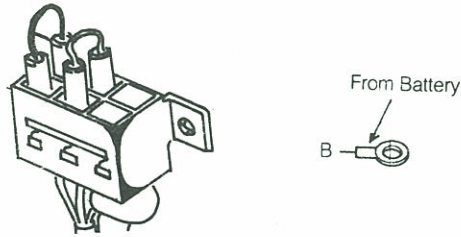

X-02 Ignition Switch [F]

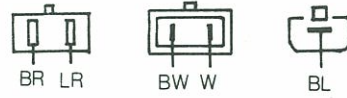

X-03 Fuse Box [F]

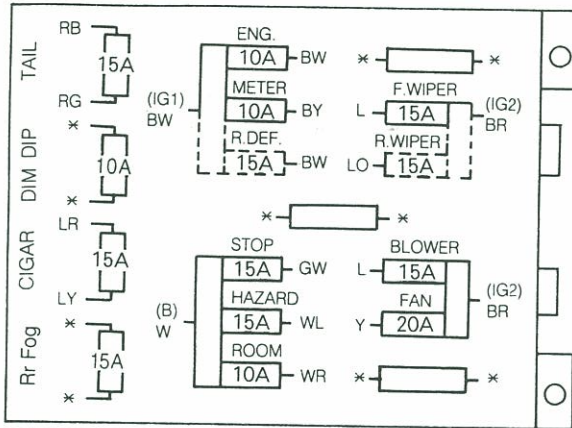

X-04 Connector Between Front [F] and Instrument Panel [I] Harness

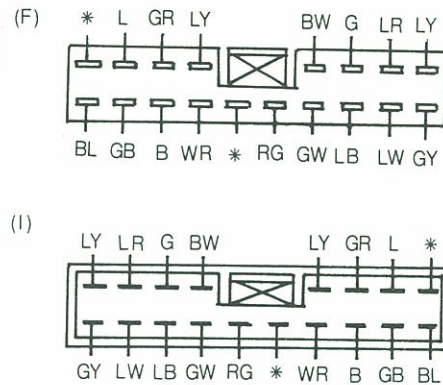

X-05 Connector Between Front [F] and Rear [R] Harness

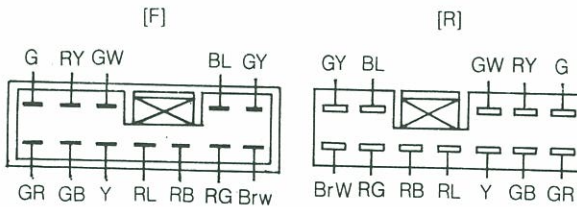

X-06 Connector Between Front [F] and Rear [R] Harness

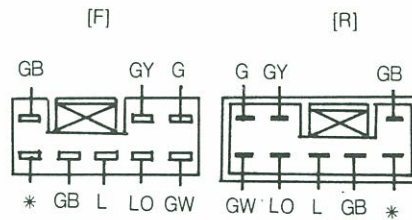

X-07 Connector Between Front [F] and Engine [E] Harness

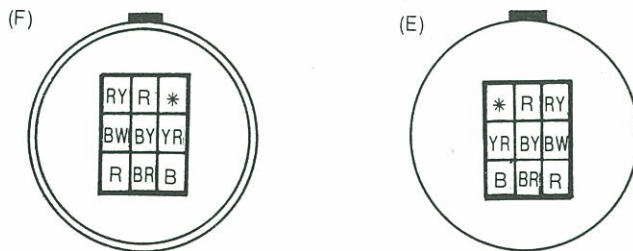

X-08 Connector Between Front [F] and Engine [E] Harness

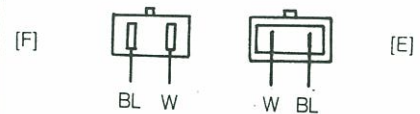

X-09 Connector Between Front [F] and Interior [In] Harness

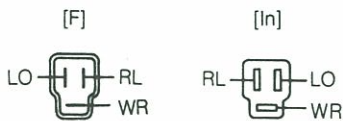

X-10 Connector Between Rear [R] and No. 2 Rear [R2] Harness

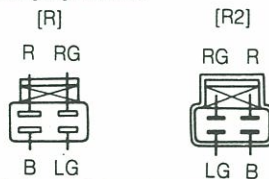

X-11 Connector Between Rear [R] and No. 2 Rear Harness

